

# Active learning and interactive lectures

## Part I: Confessions of a converted lecturer

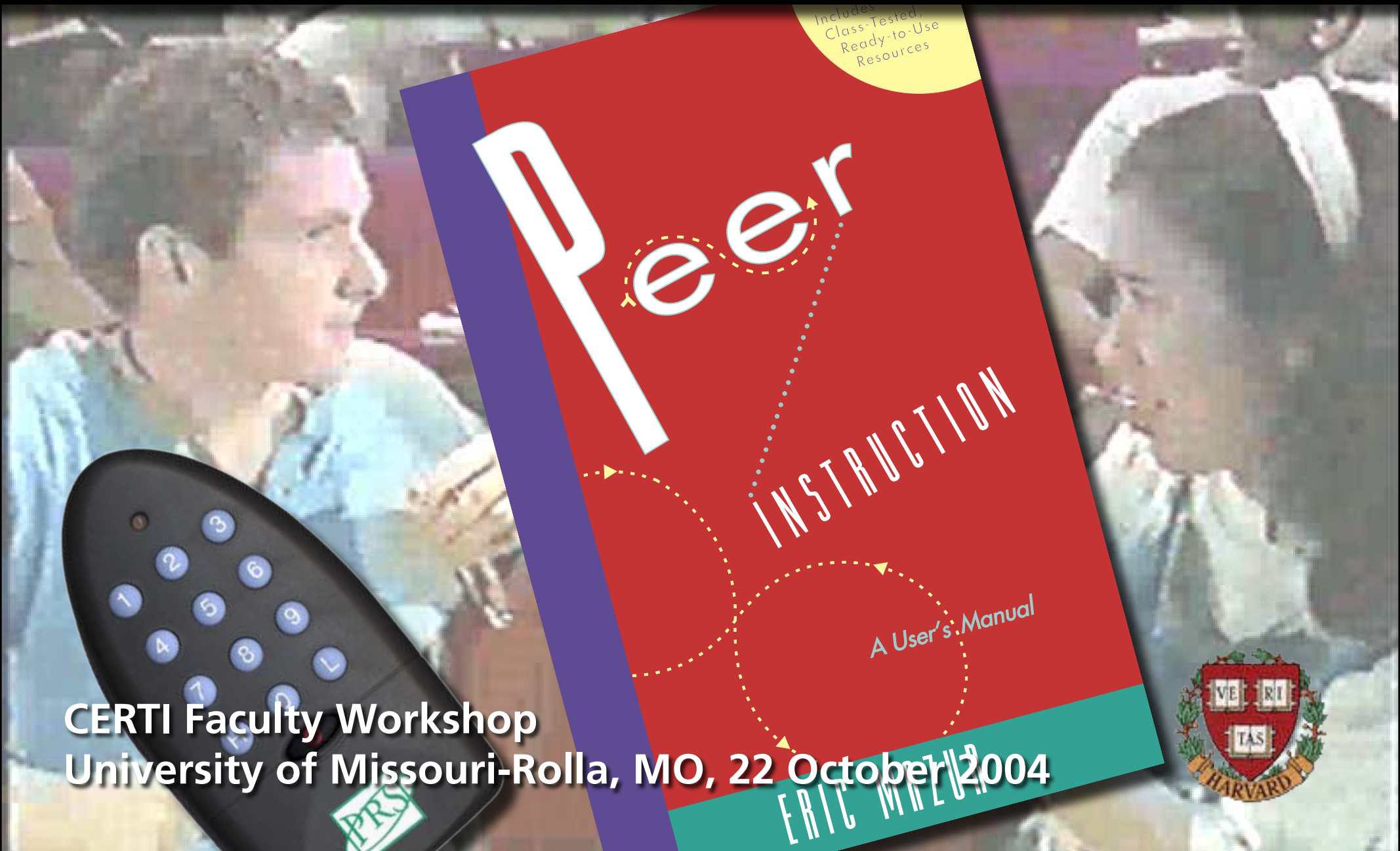

Includes  
Class-Tested,  
Ready-to-Use  
Resources

# Peer

## INSTRUCTION

A User's Manual

ERIC MAZUR

CERTI Faculty Workshop  
University of Missouri-Rolla, MO, 22 October 2004



# Outline

- Problem



# Outline

- Problem

- Cause



# Outline

A photograph of a group of people sitting around a table in a meeting. The image is semi-transparent, with text overlaid on it. The text is arranged in a list format. The background shows several people engaged in a discussion, with one person in the foreground gesturing with their hands.

- **Problem**

- **Cause**

- **Remedy**

# We have a problem

340,000 students take  
introductory physics  
each year

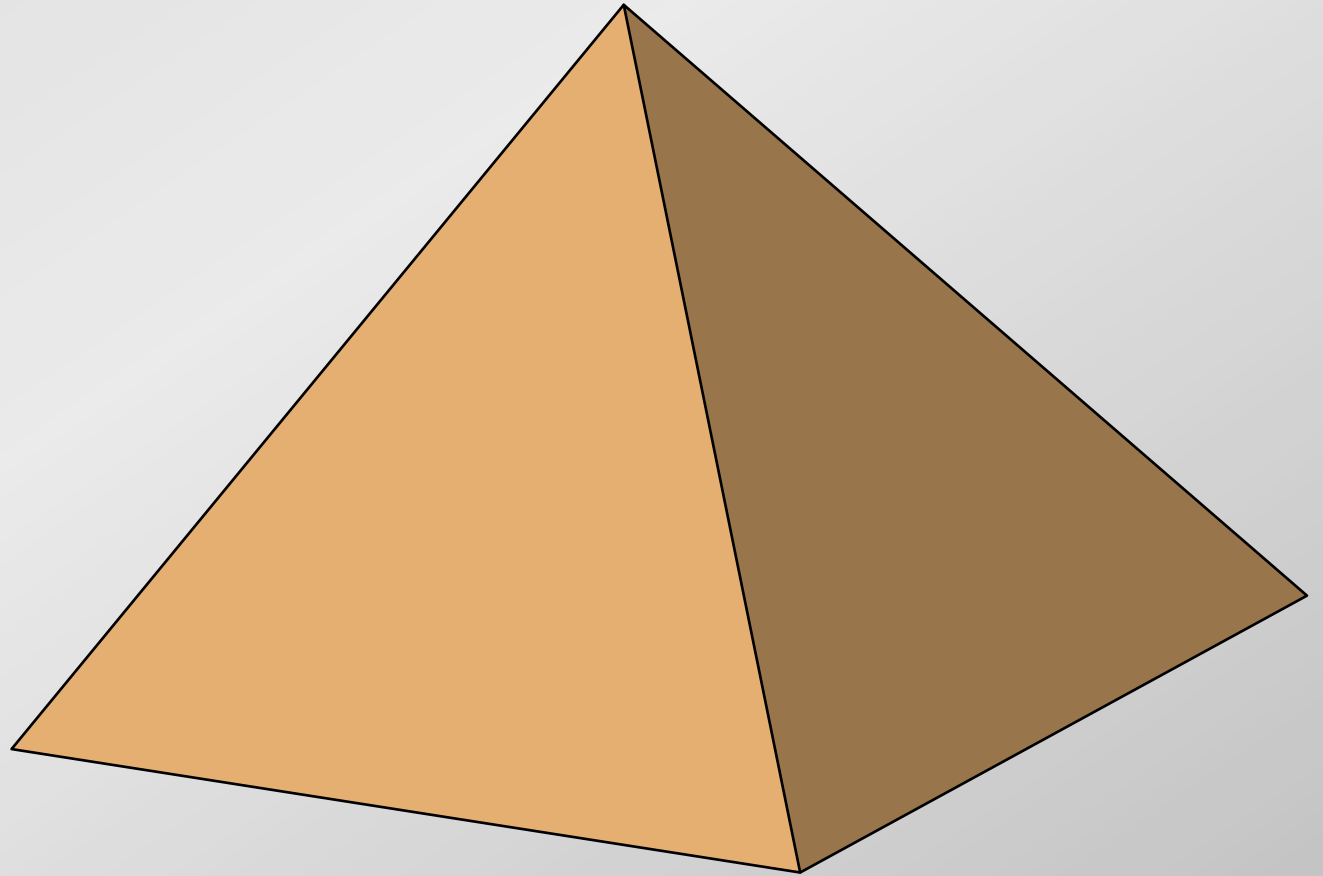

AIP Report R-151.39 (2003)

# We have a problem

about 1% of these get  
a bachelor's degree  
in physics

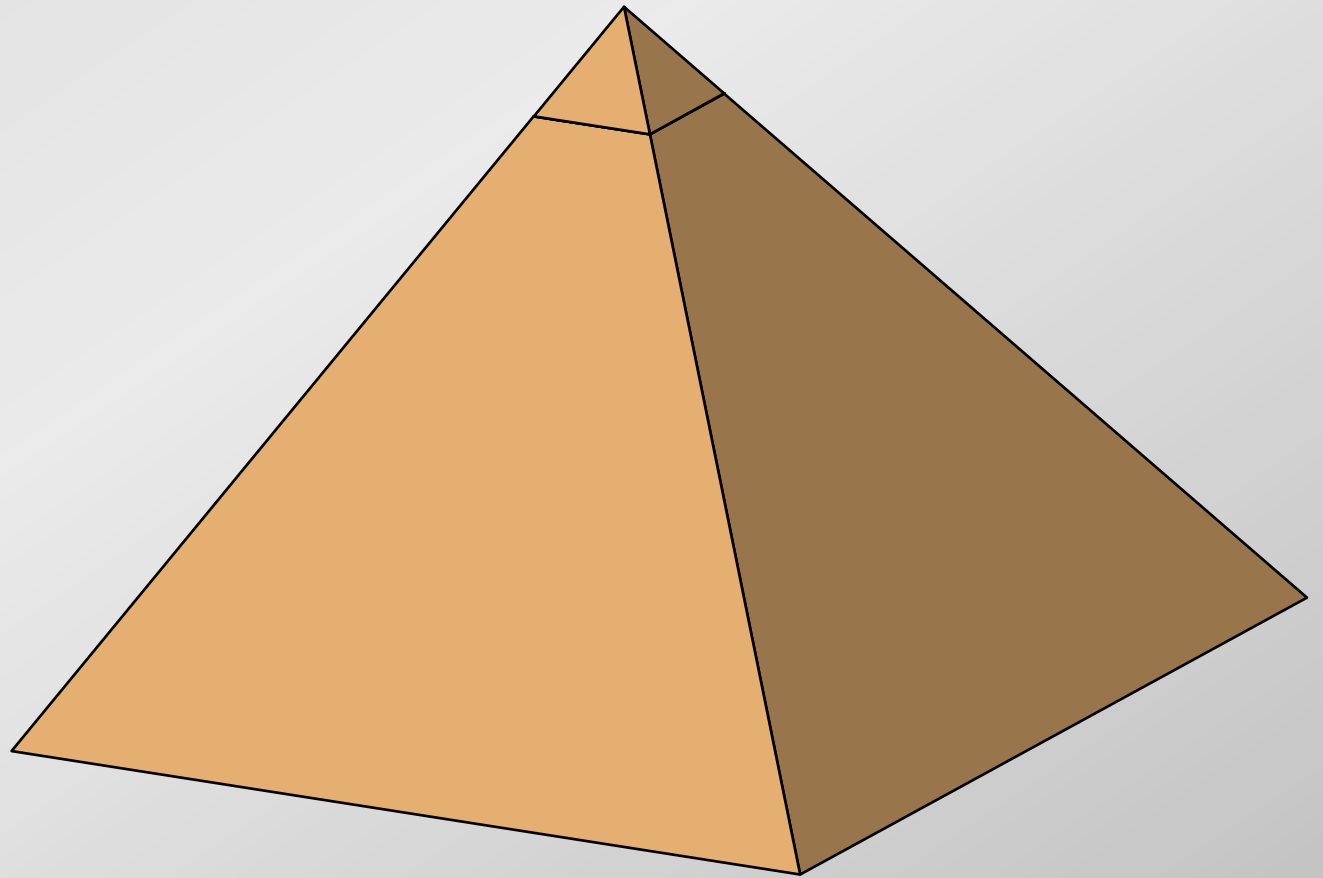

# We have a problem

Of the 4,100 students with  
a bachelor's degree  
in physics...

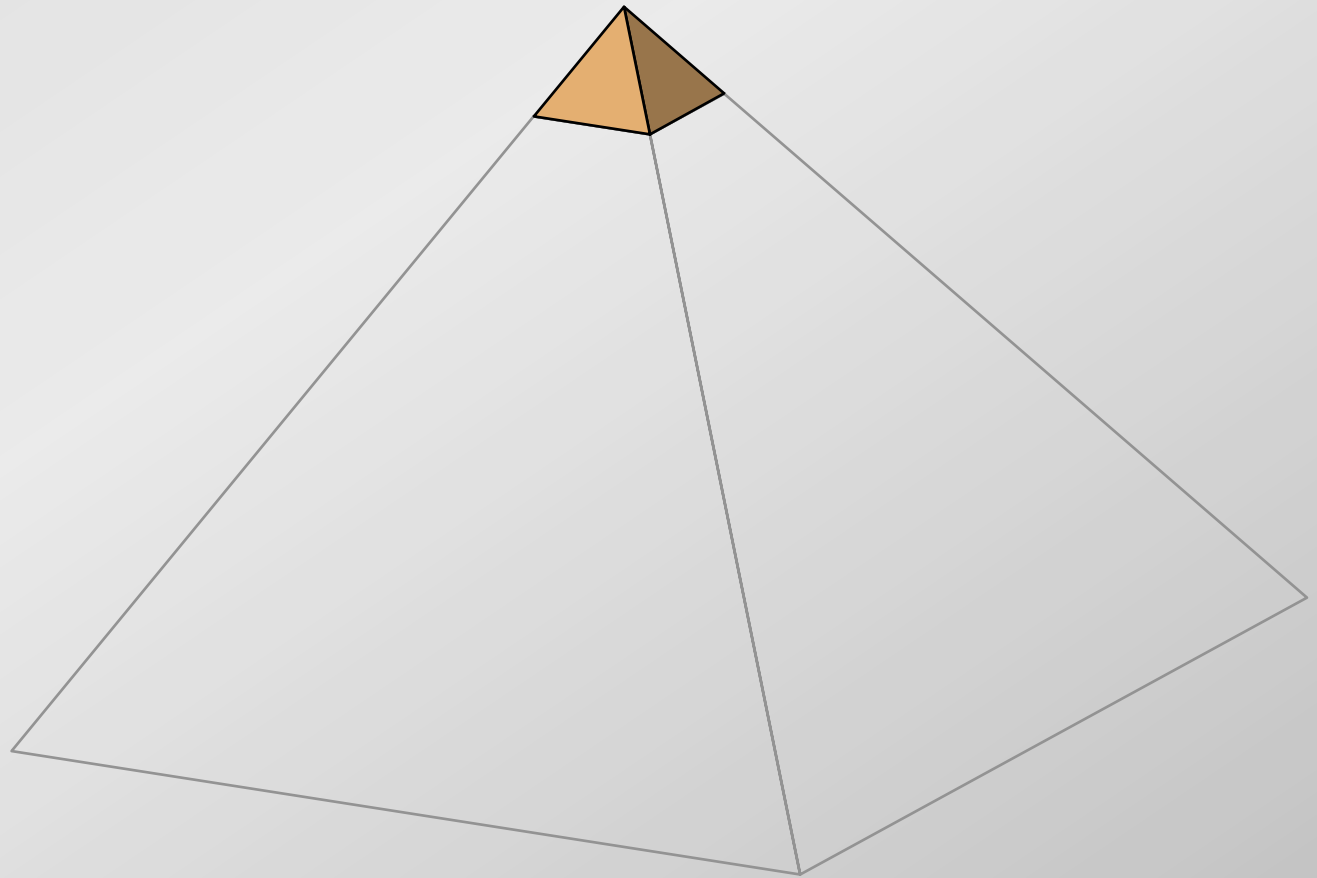

# We have a problem

about 28% go on to get a  
Ph.D. in physics...

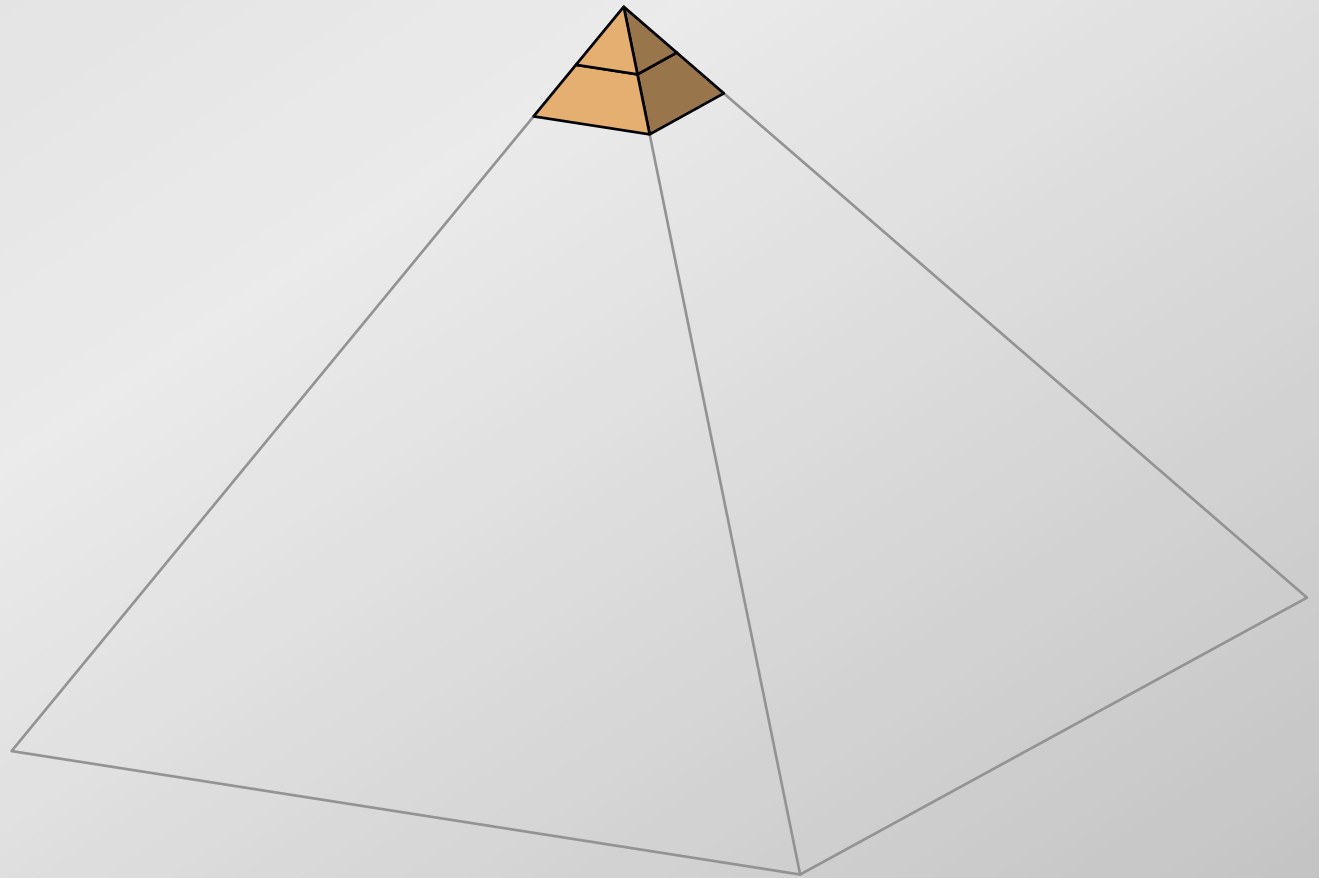



# We have a problem

That's one out of every  
300 students in our  
introductory  
courses!

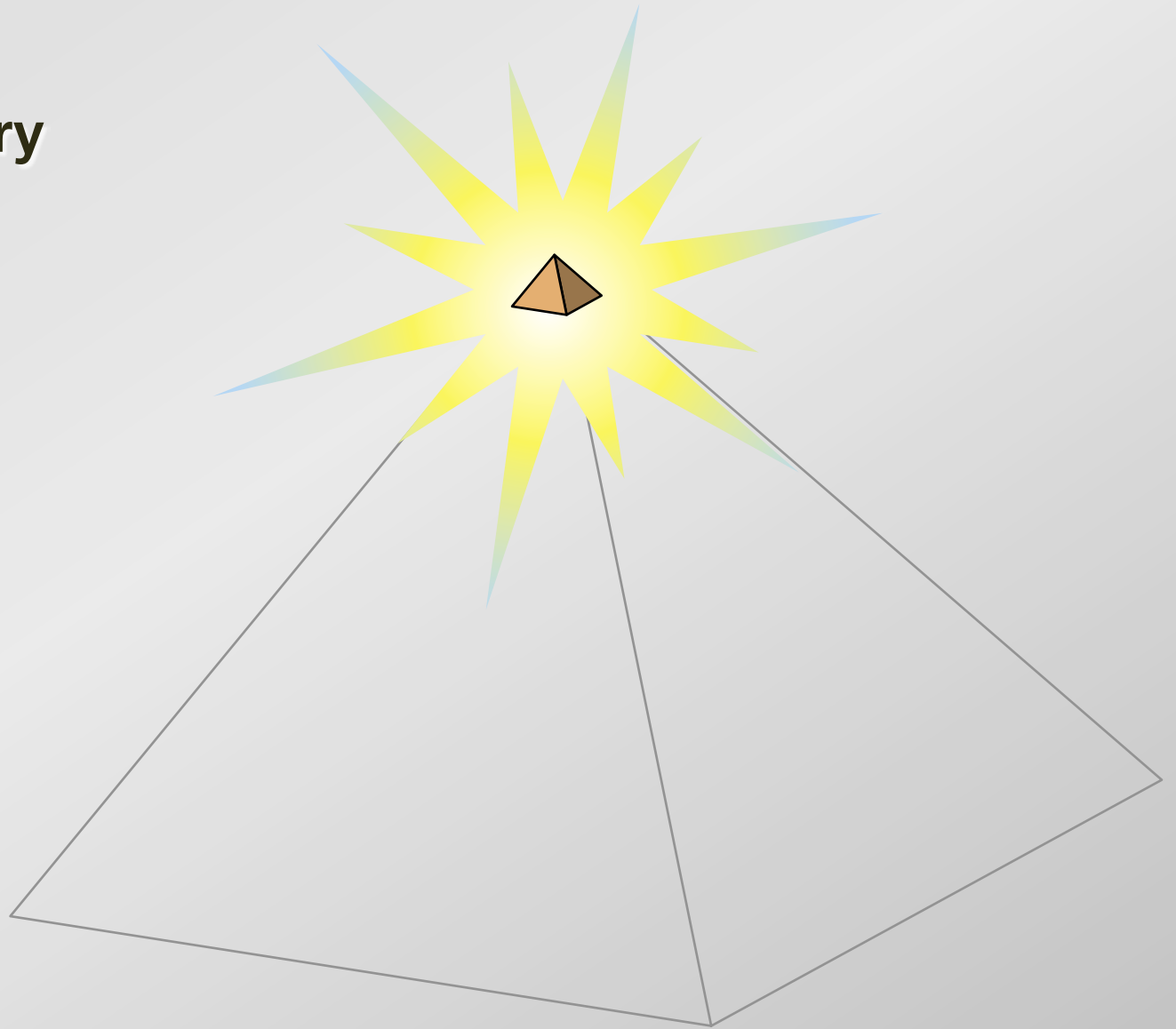

# We have a problem

What about the  
other 299...?

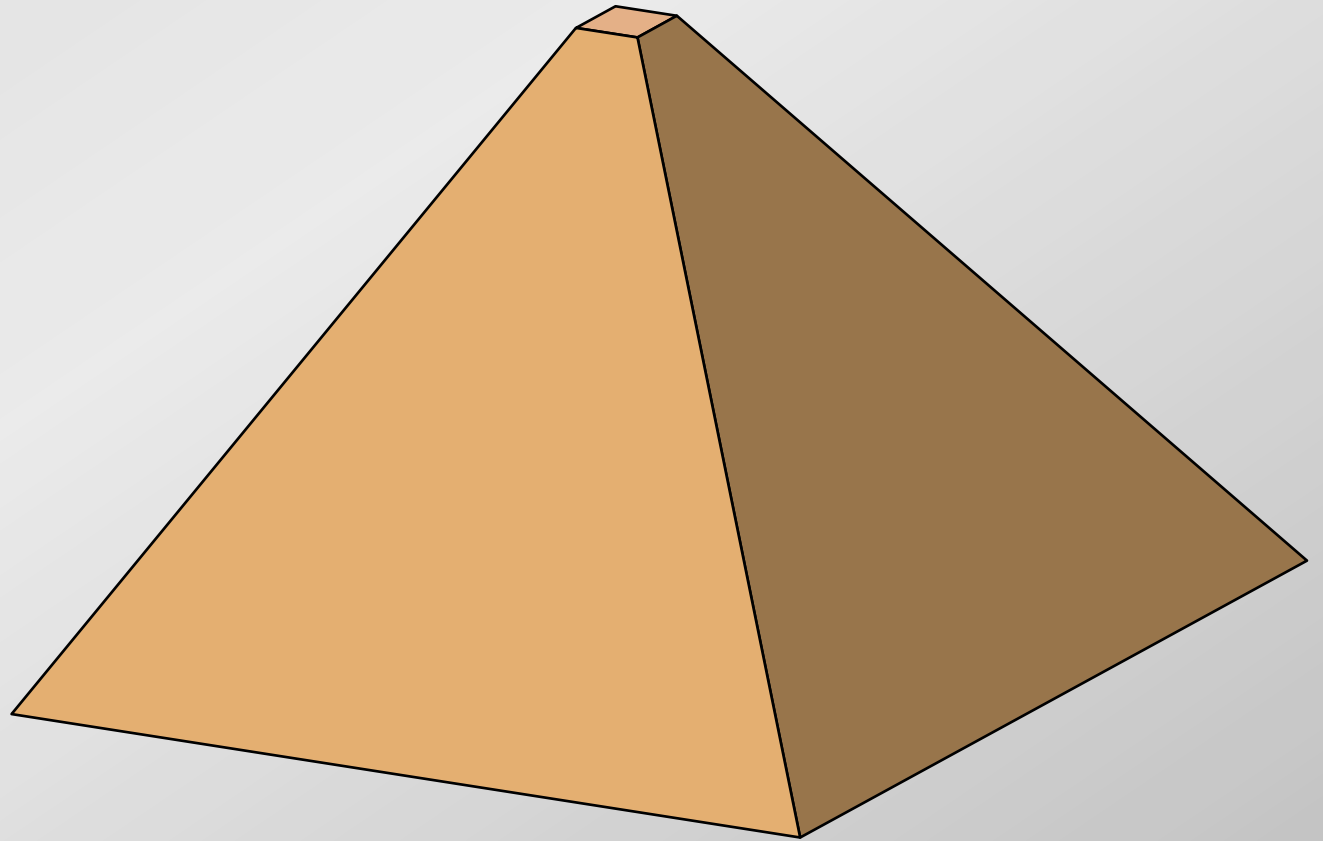

# We have a problem

What do we know  
about these  
students?

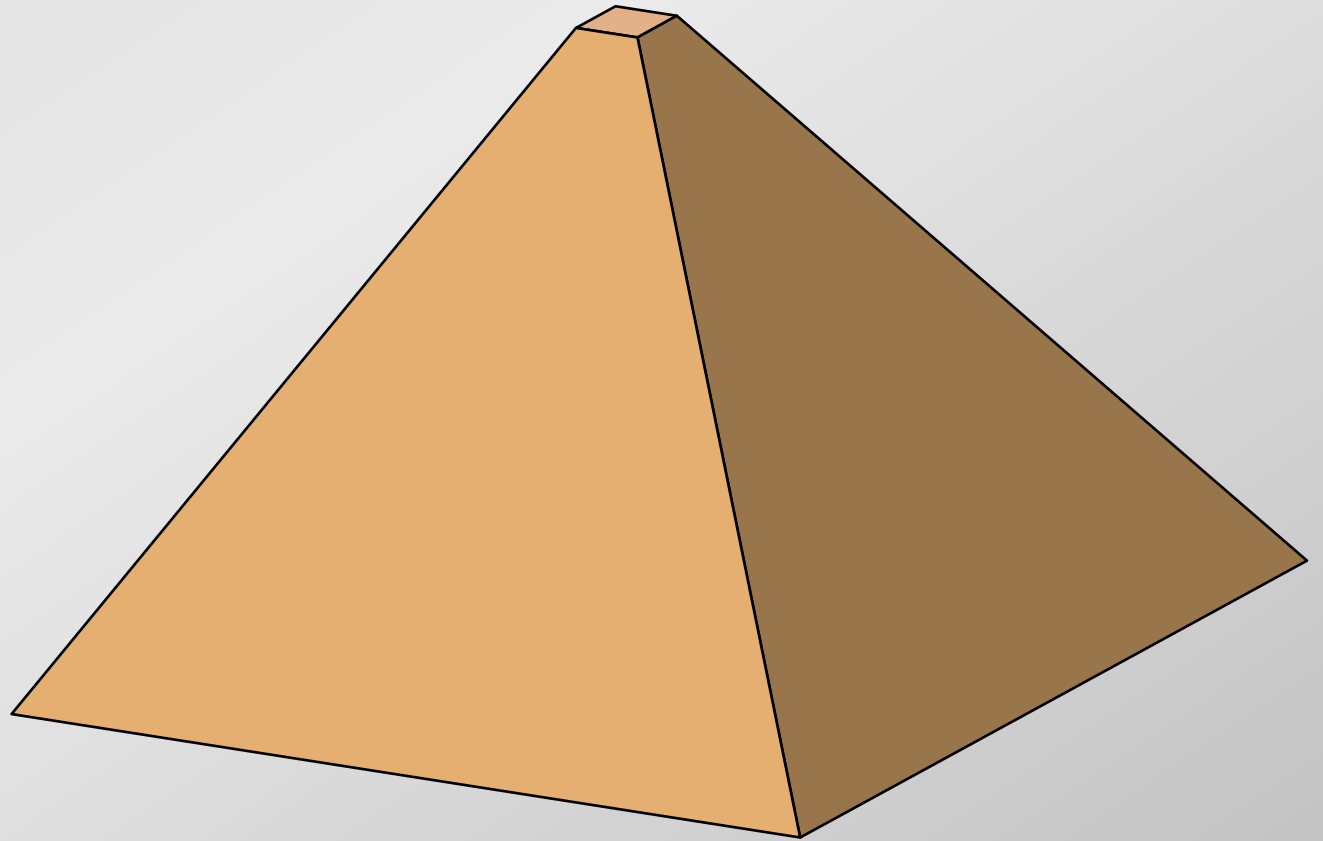

# **We have a problem**

**Some disturbing symptoms:**

- **frustration**
- **lack of understanding**
- **lack of basic knowledge**



# We have a problem

They know the jargon:

- circular motion
- barometric pressure
- light radius
- something to the power times ten to the something

# We have a problem

They are aware of their lack of knowledge:

- I graduated from college, but I didn't study *astronomy*
- It's been a while since I've had physics

# We have a problem

They are aware of their lack of knowledge:

- I graduated from college, but I didn't study *astronomy*
- It's been a while since I've had physics

**...and they don't care!**



# **We have a problem**

**Should we worry?**

**We have a problem**

**We'd better!**



# We have a problem

"I took four years of science  
and four years of math...

A waste of my time,  
a waste of the teacher's time,  
and a waste of space...

You know, I took *physics*.

For *what?*"



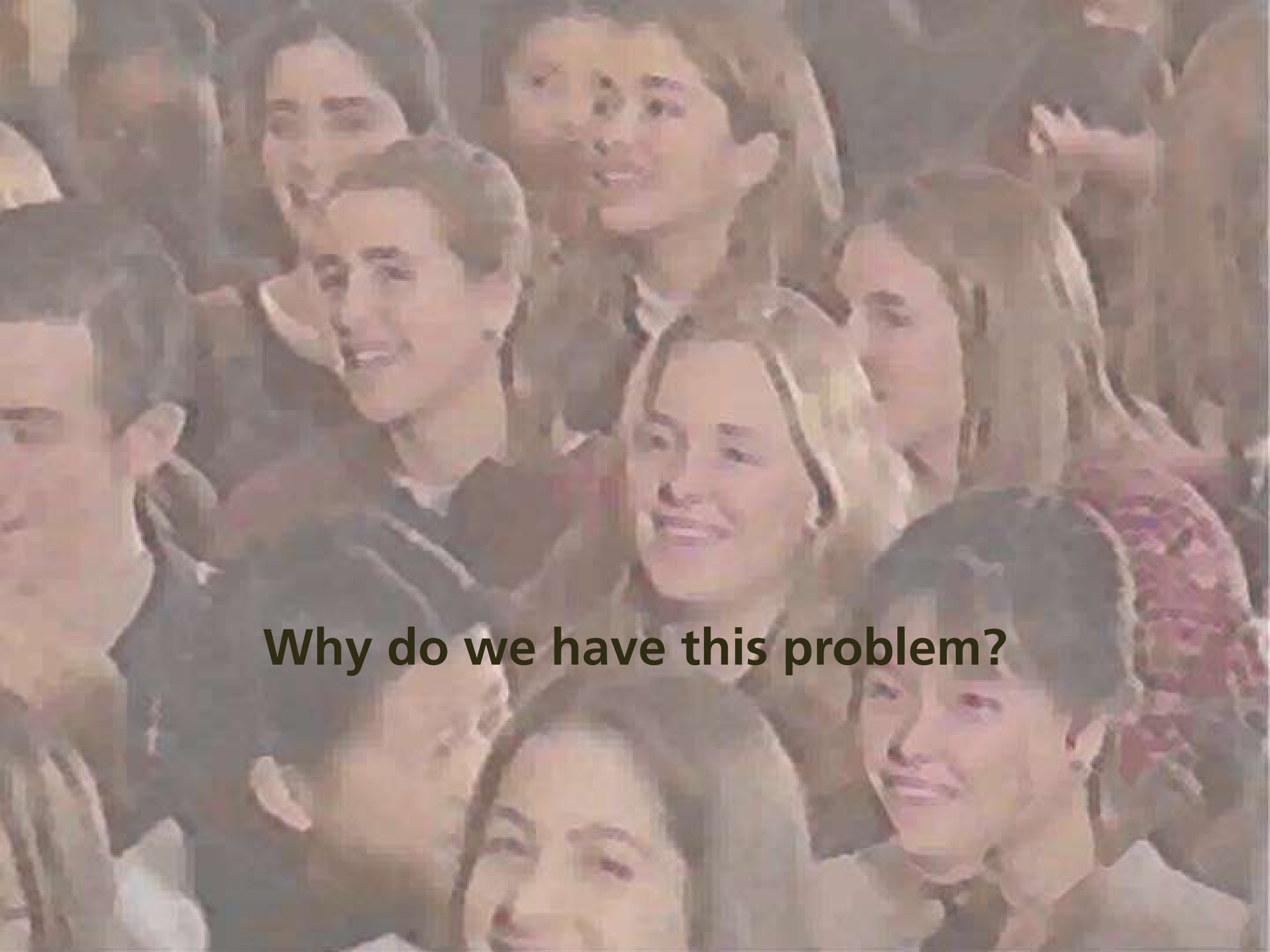

**Why do we have this problem?**

**Why do we have this problem?**

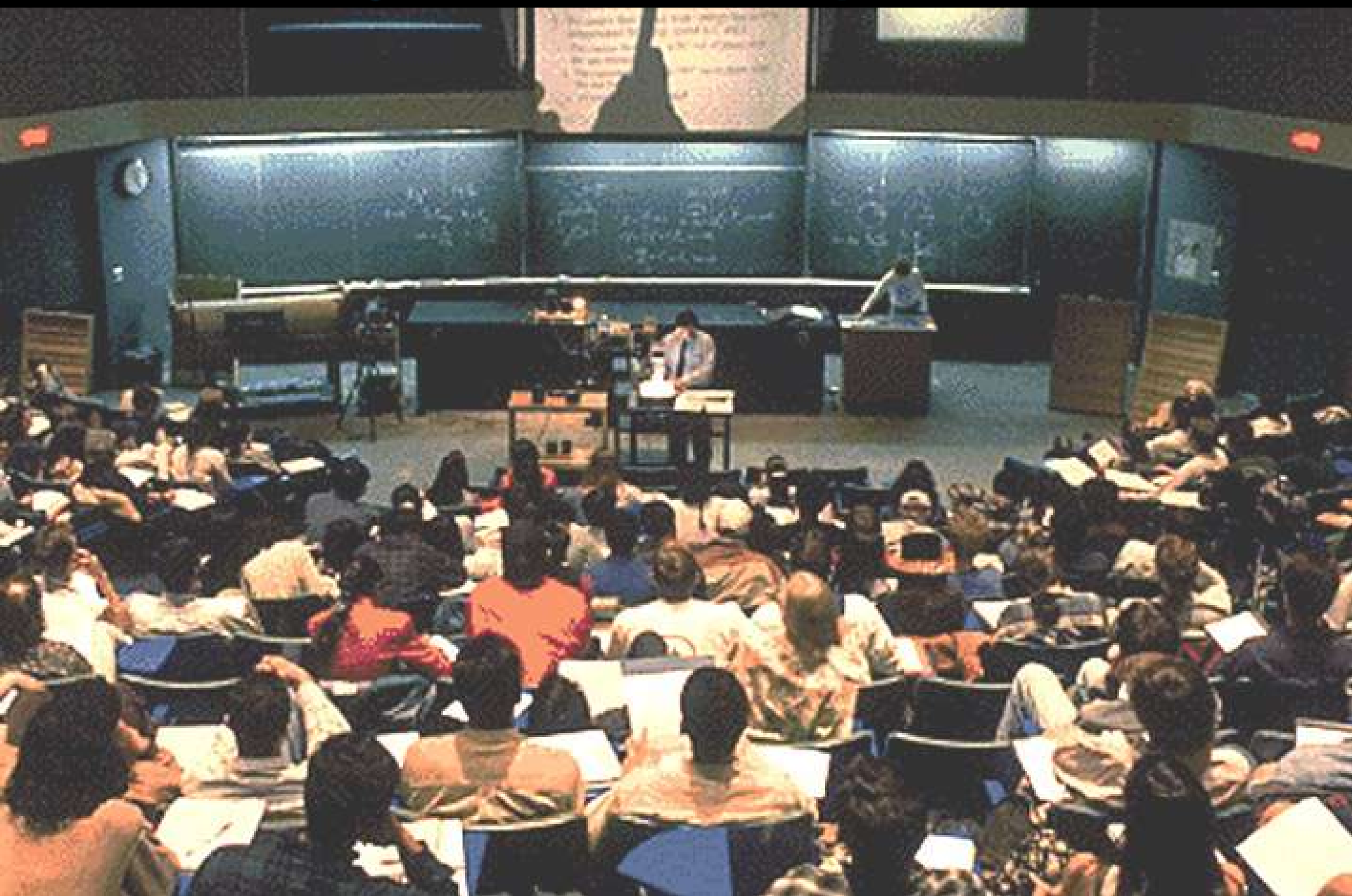

# Why do we have this problem?

lectures focus on delivery of information

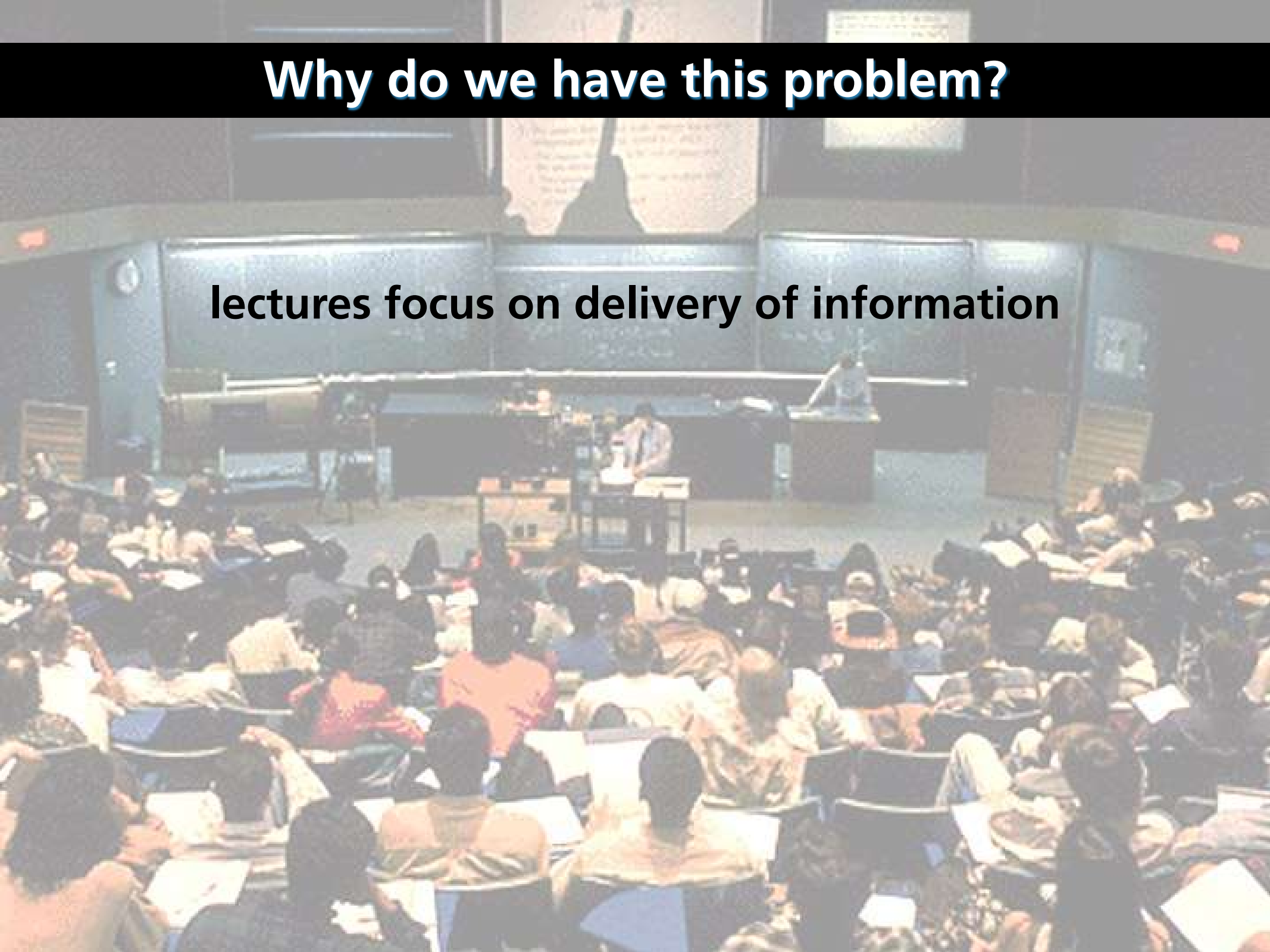

# Why do we have this problem?

education is not just information transfer

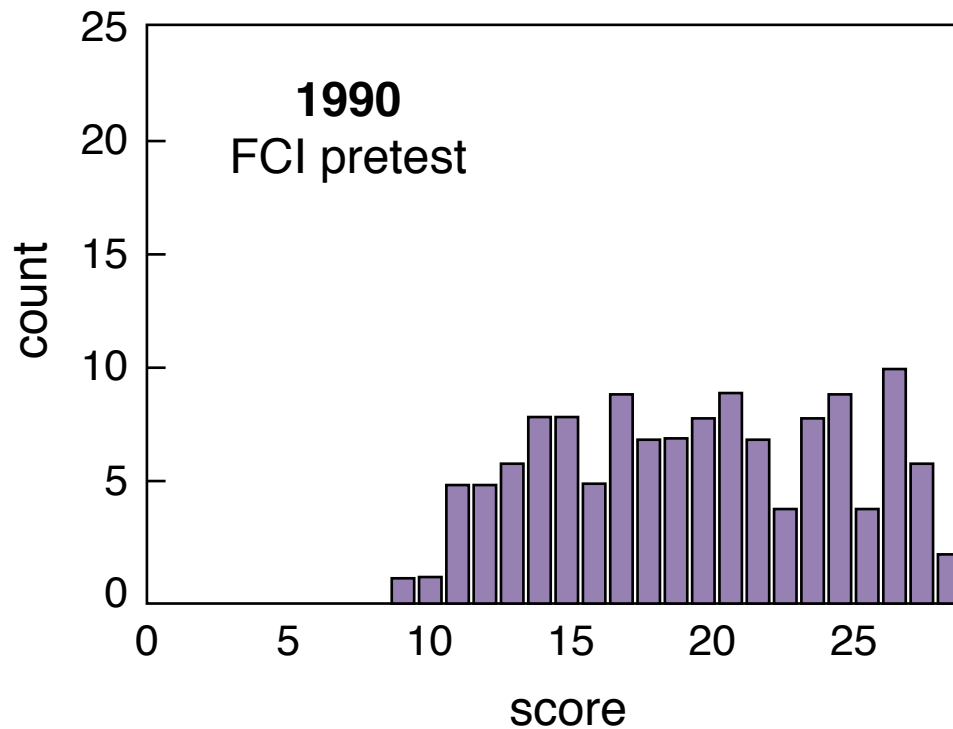



# Why do we have this problem?

education is not just information transfer

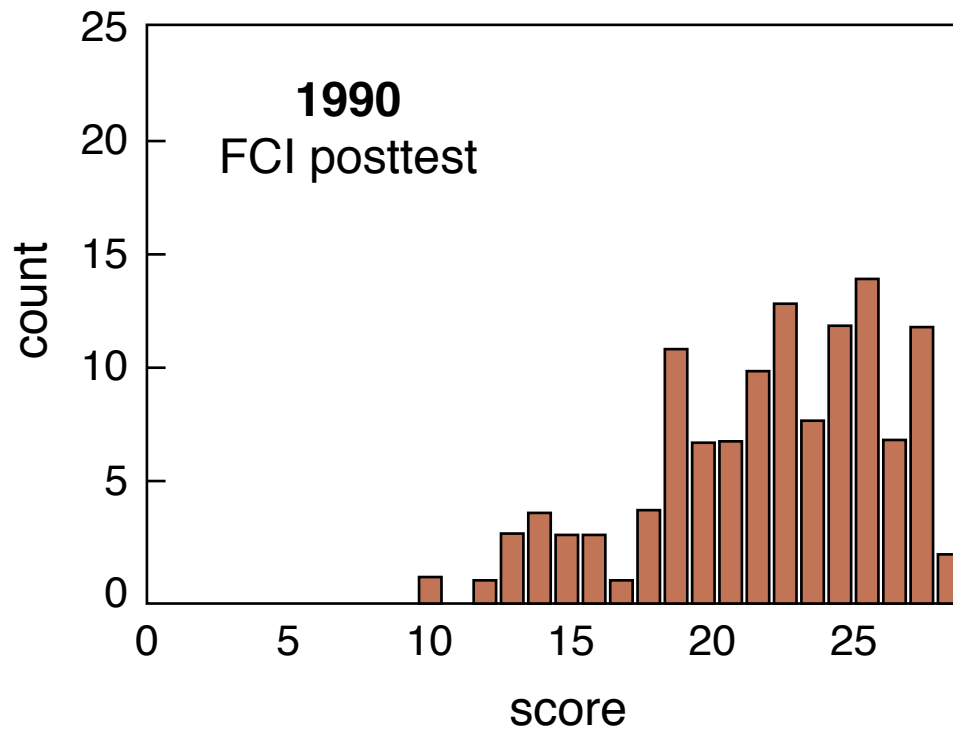

# Why do we have this problem?

education is not just information transfer

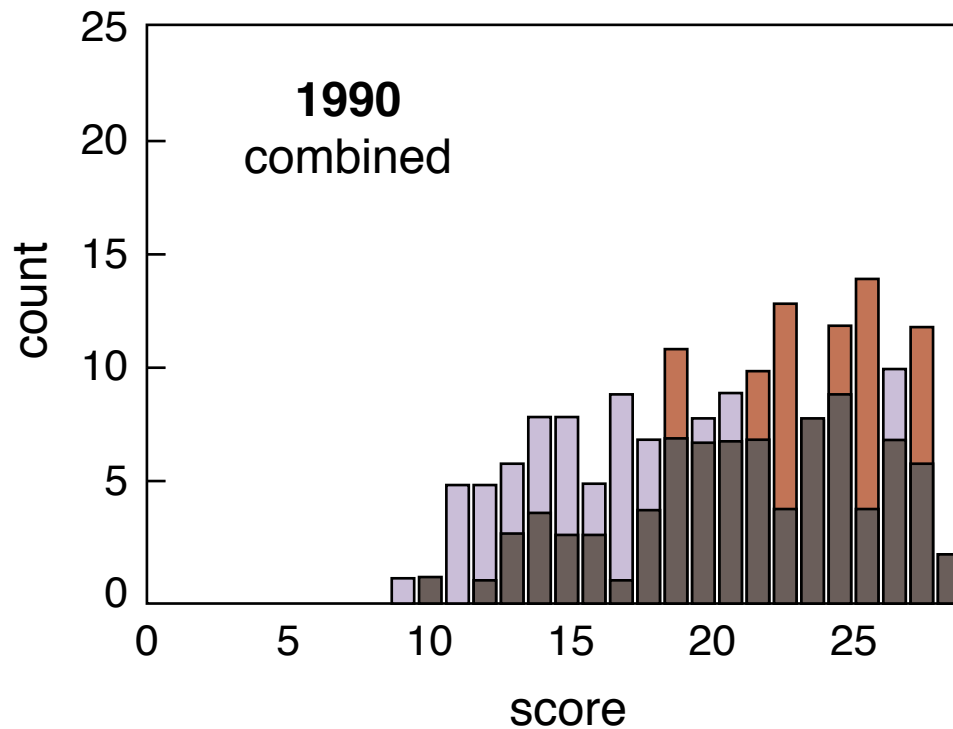

# Why do we have this problem?

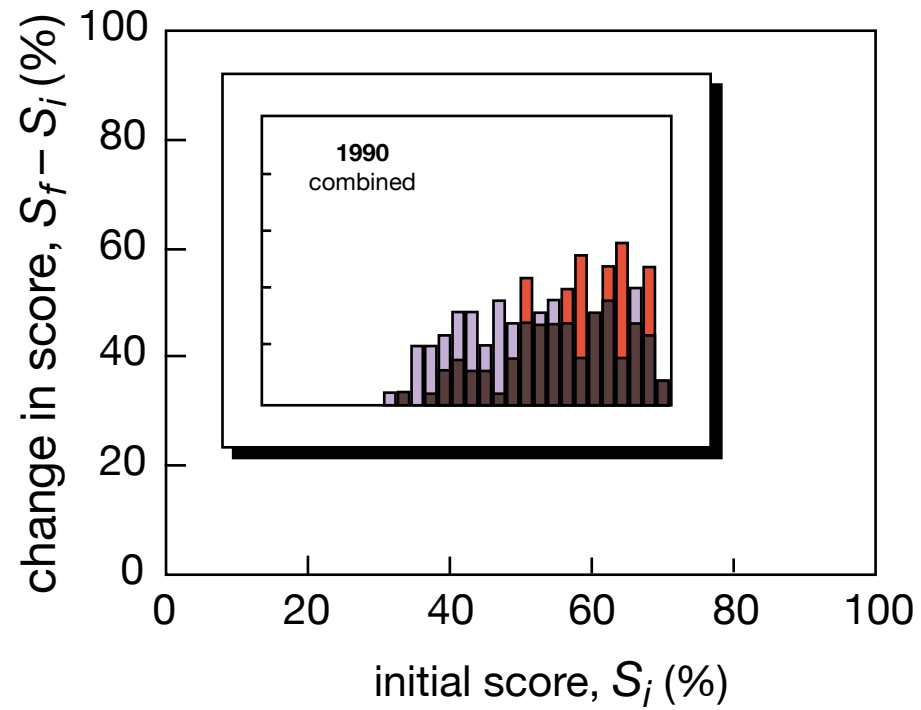

# Why do we have this problem?

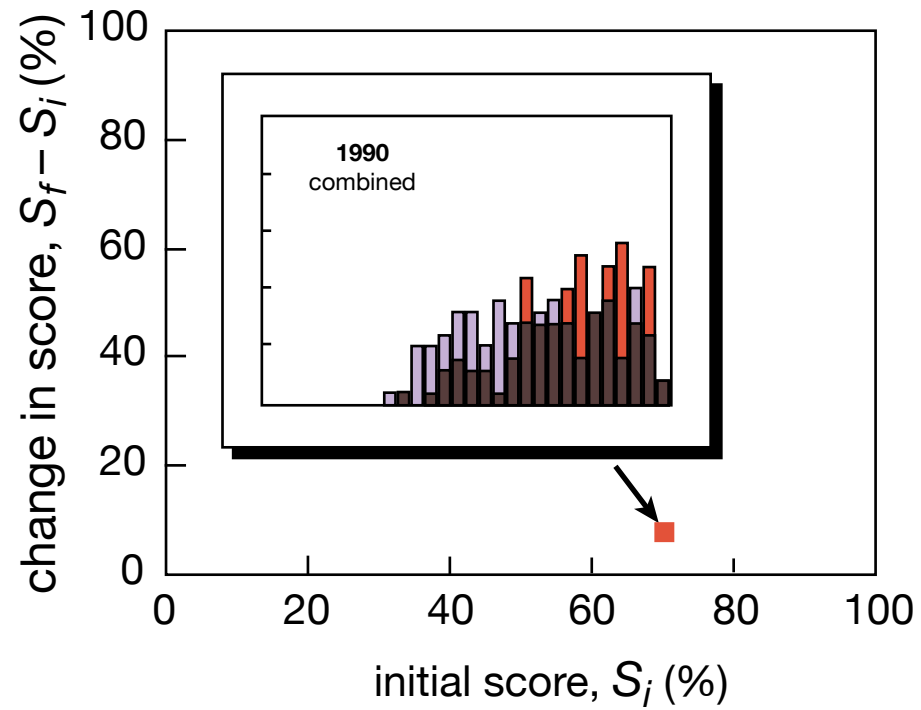

# Why do we have this problem?

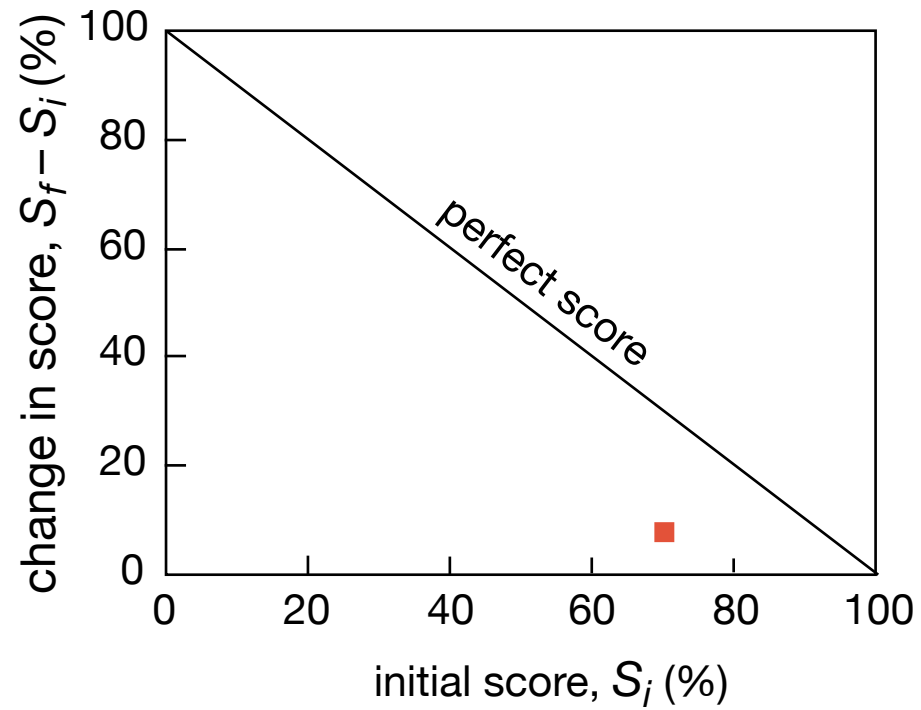

# Why do we have this problem?

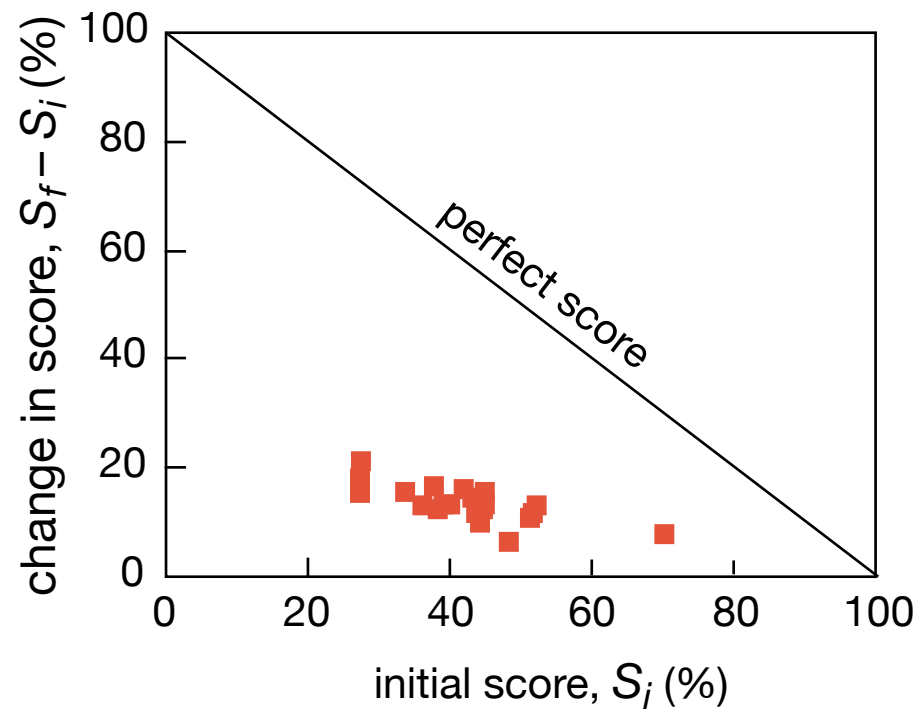

# Why do we have this problem?

only one quarter of maximum gain realized

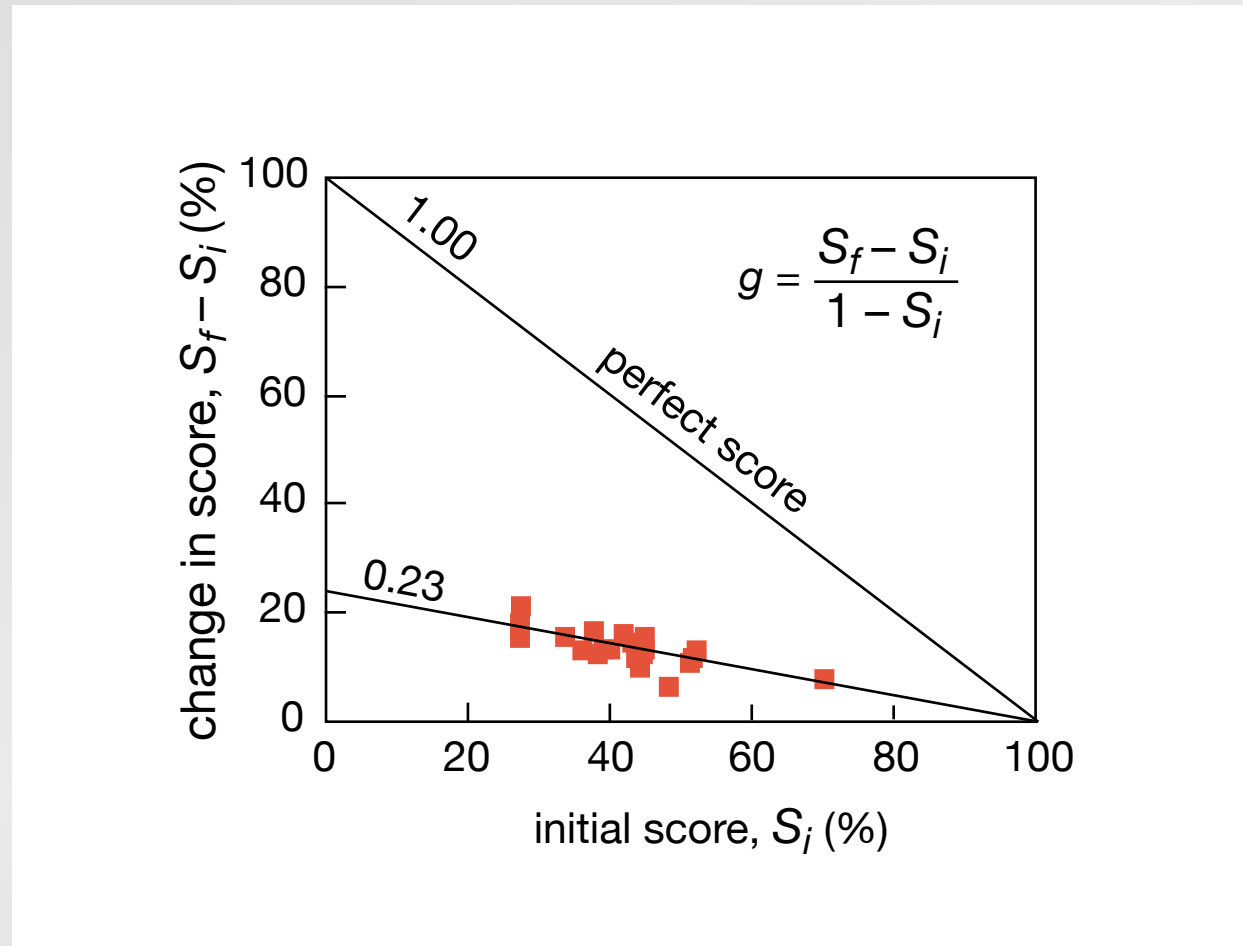

# Why do we have this problem?

not transfer but assimilation of information is key

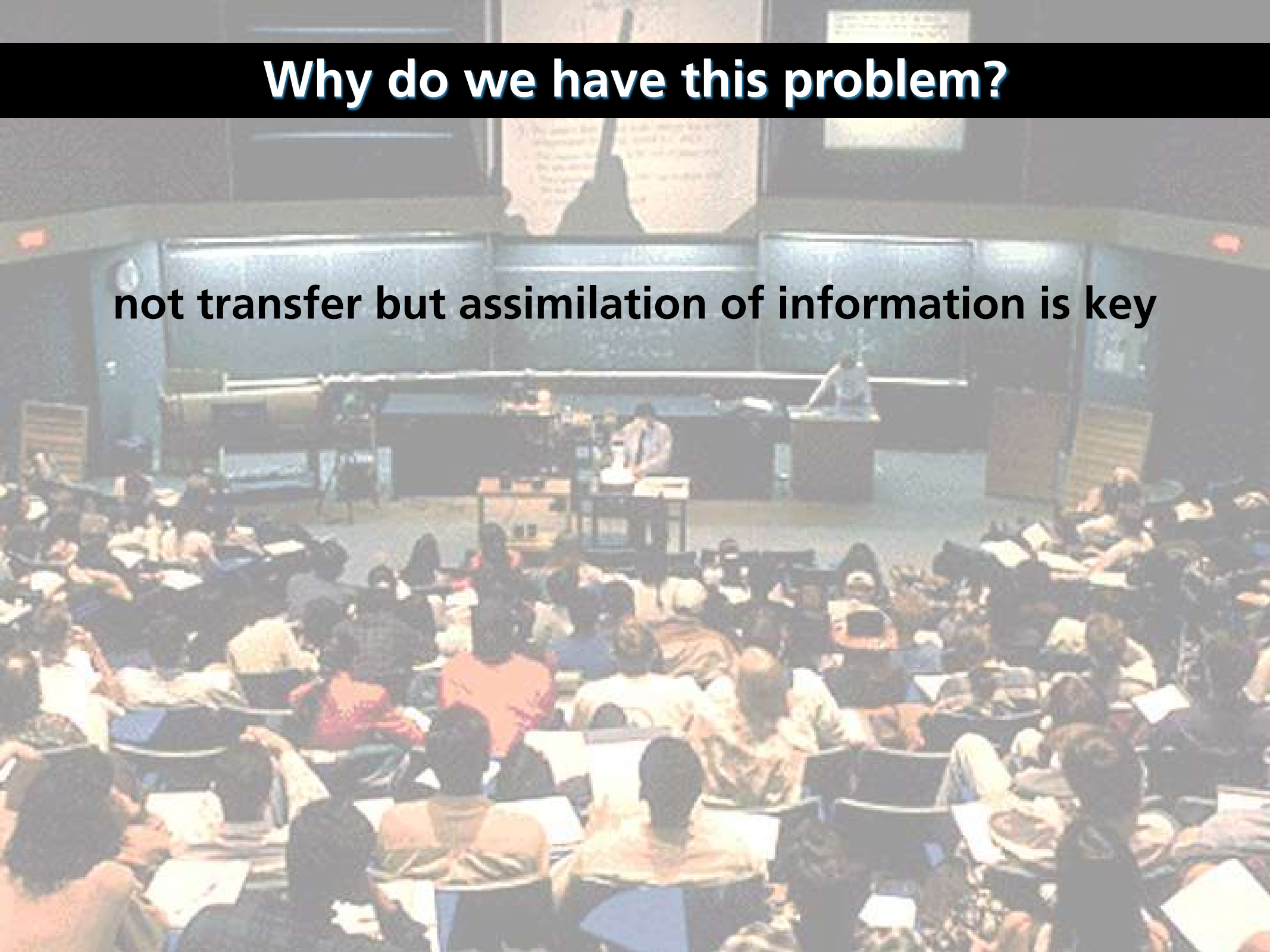



# Why do we have this problem?

conventional problems reinforce bad study habits

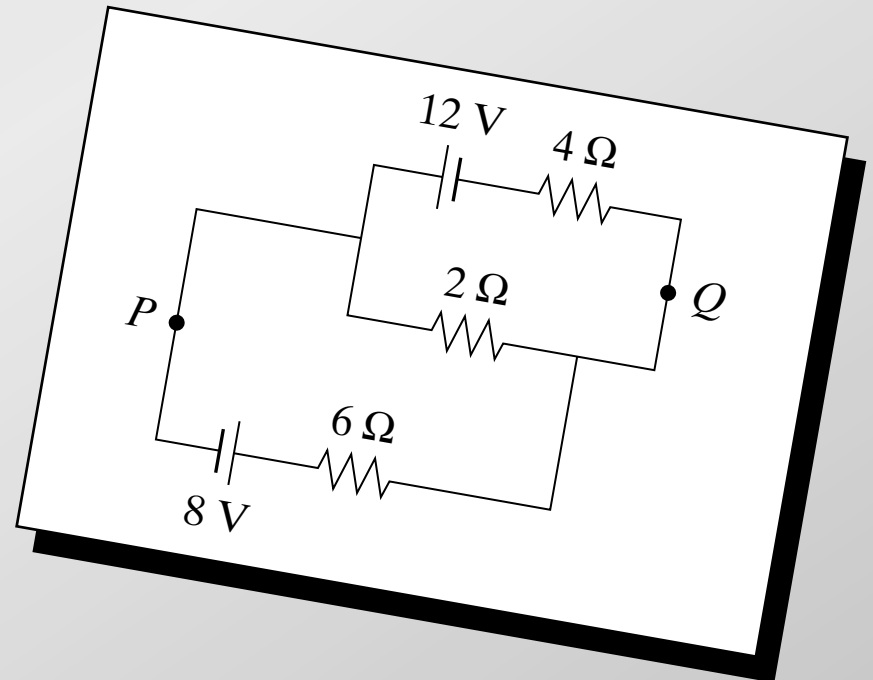

# Why do we have this problem?

conventional problems reinforce bad study habits

Calculate:

(a) current in  $2\text{-}\Omega$  resistor

(b) potential difference

between  $P$  and  $Q$

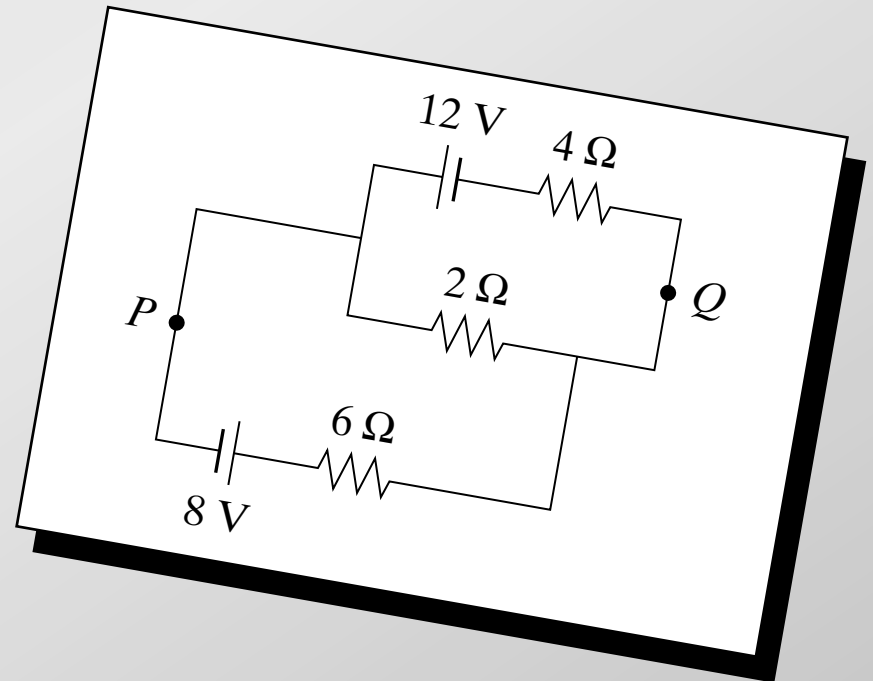

# Why do we have this problem?

are the basic principles understood?

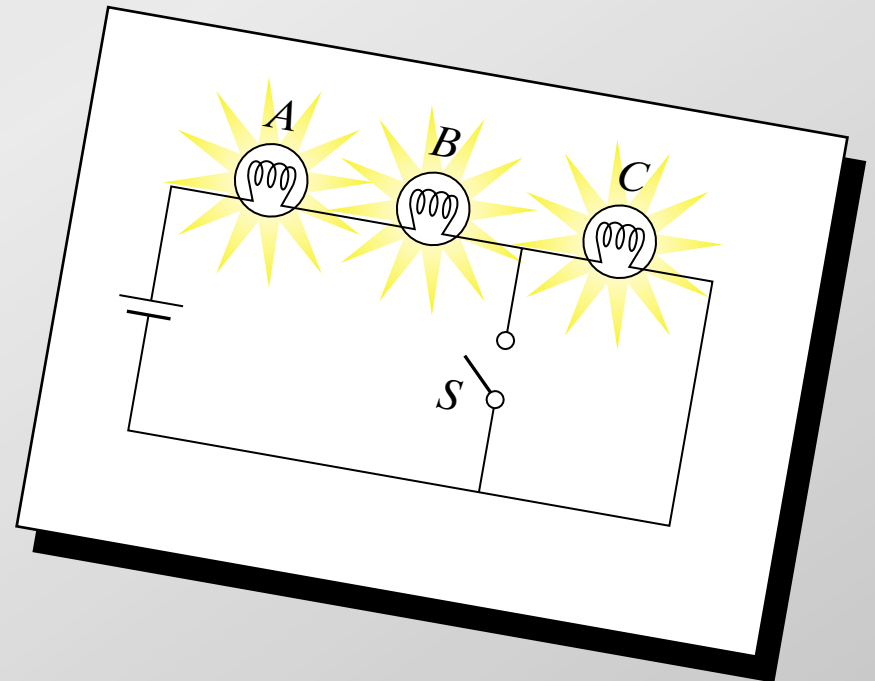

# Why do we have this problem?

are the basic principles understood?

When  $S$  is closed, what happens to:

- (a) intensities of  $A$  and  $B$ ?
- (b) intensity of  $C$ ?
- (c) current through battery?
- (d) potential difference across  
 $A$ ,  $B$ , and  $C$ ?
- (e) the total power dissipated?

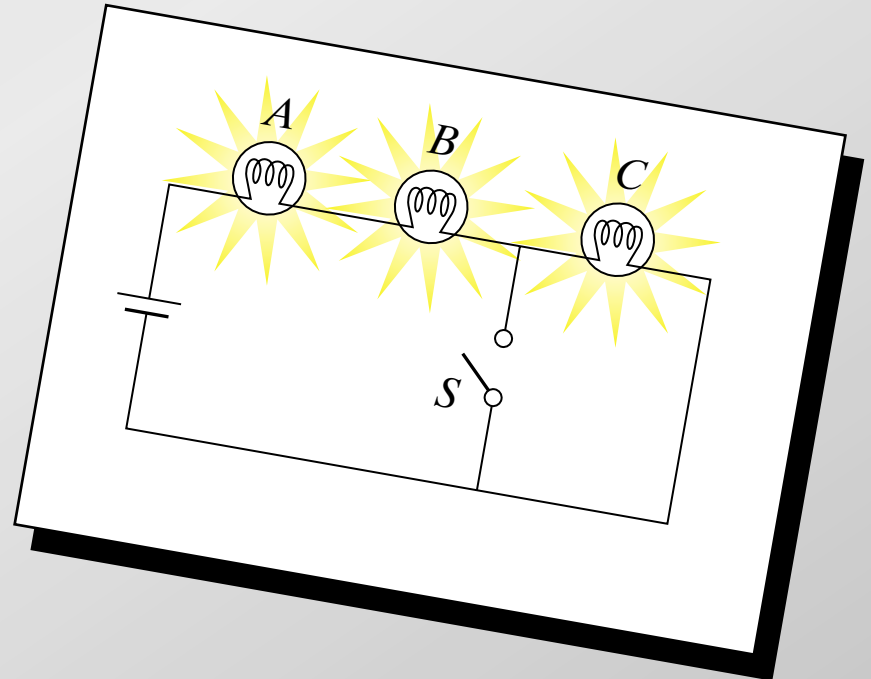

# Why do we have this problem?

conventional

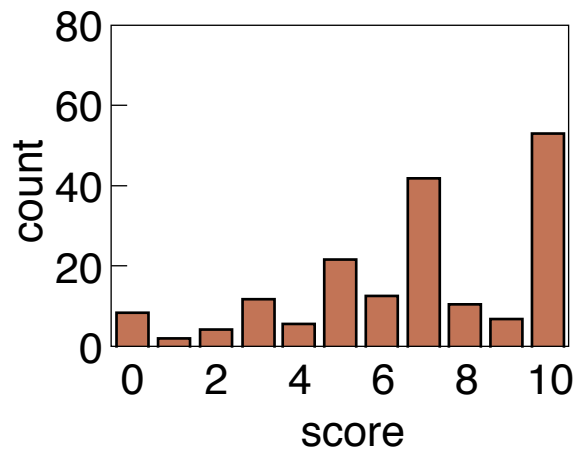

conceptual

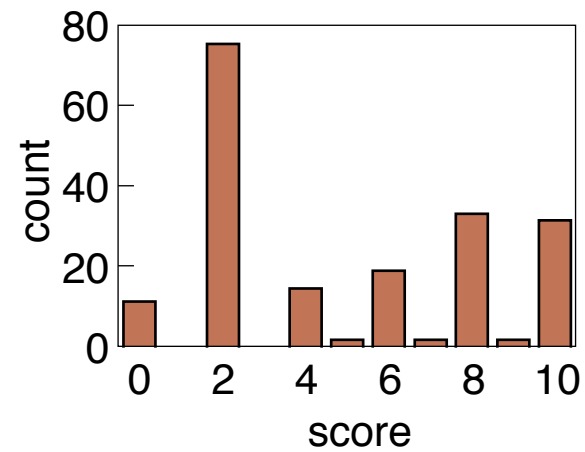

# Why do we have this problem?

conventional

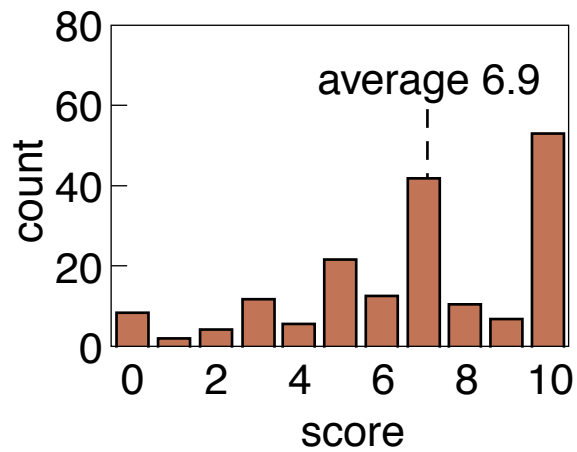

conceptual

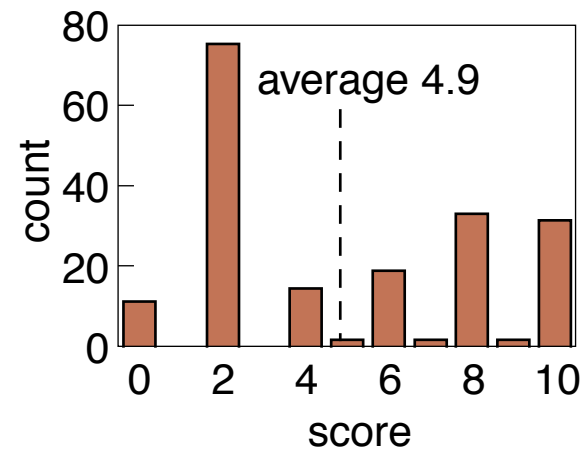

# Why do we have this problem?

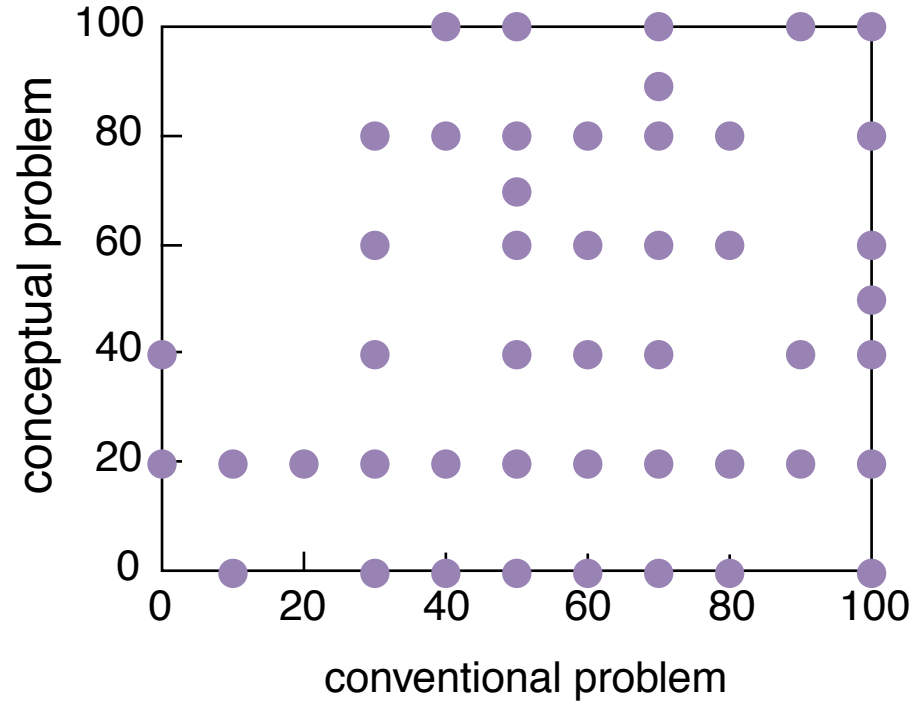

# Why do we have this problem?

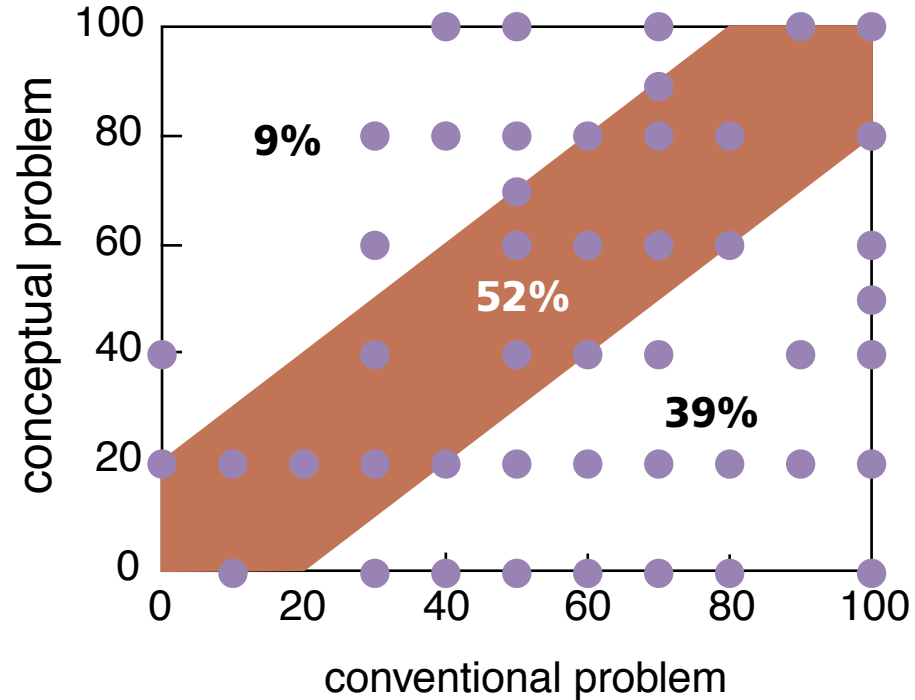



A large lecture hall with a professor at a podium and students seated at desks. A large screen at the front displays a document with a pen nib. The text "So what should we do?" is overlaid in the center of the image.

So what should we do?

# Peer Instruction

**Give students more responsibility for gathering information...**

# Peer Instruction

**Give students more responsibility for gathering information...  
so we can better help them assimilate it.**

# Peer Instruction

## Main features:

- pre-class reading
- in-class: depth, not 'coverage'
- ConcepTests

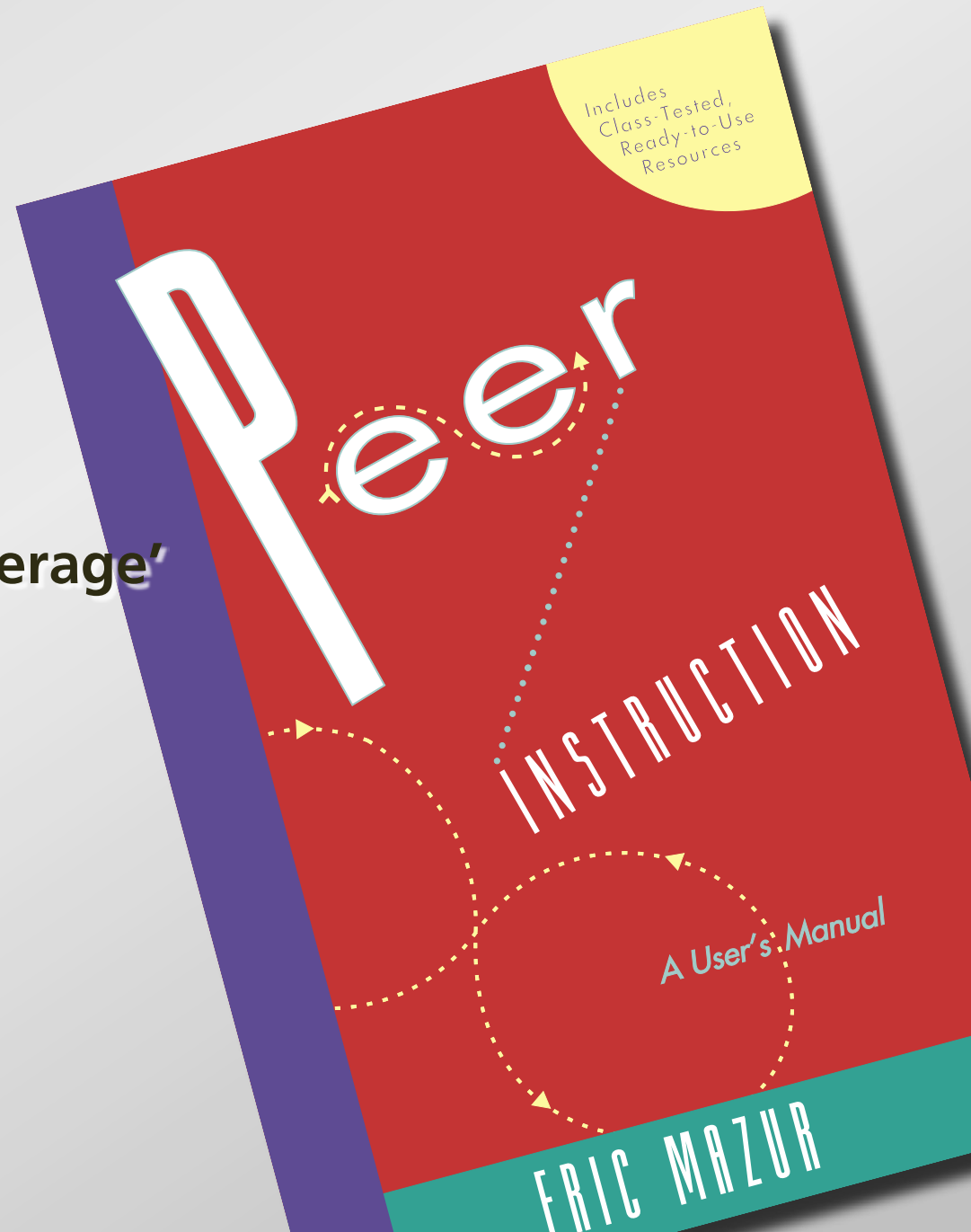

# Peer Instruction

**ConcepTest:**

- 1. Question**
- 2. Thinking**
- 3. Individual answer**
- 4. Peer discussion**
- 5. Revised/Group answer**
- 6. Explanation**



# Peer Instruction

is it any good?

# Peer Instruction

first year of implementing PI

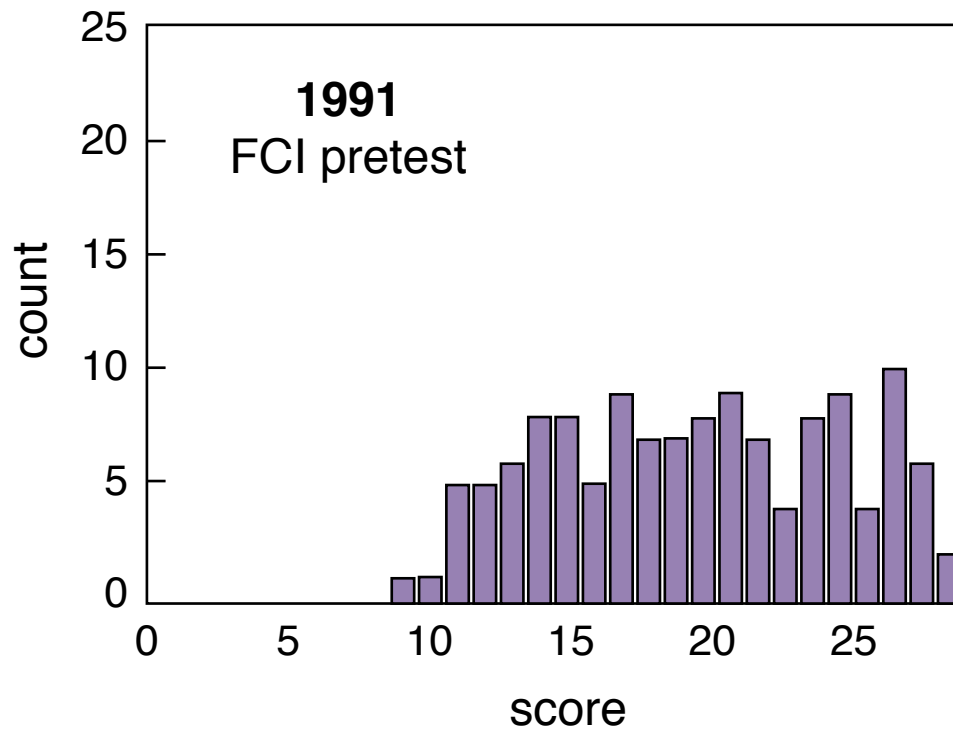



# Peer Instruction

first year of implementing PI

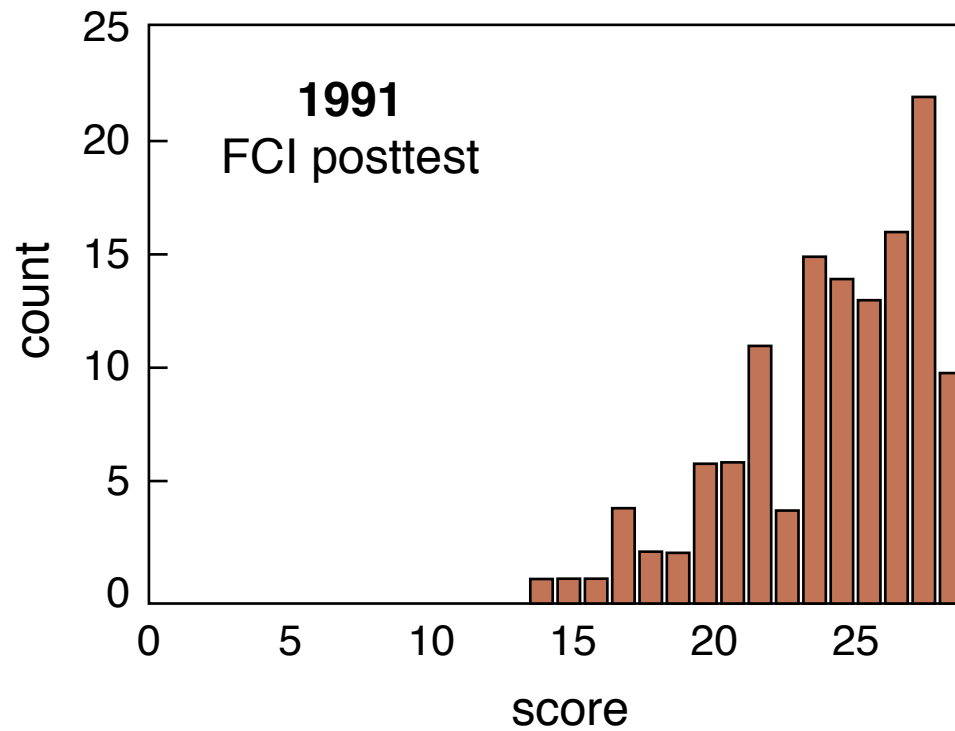

# Peer Instruction

first year of implementing PI

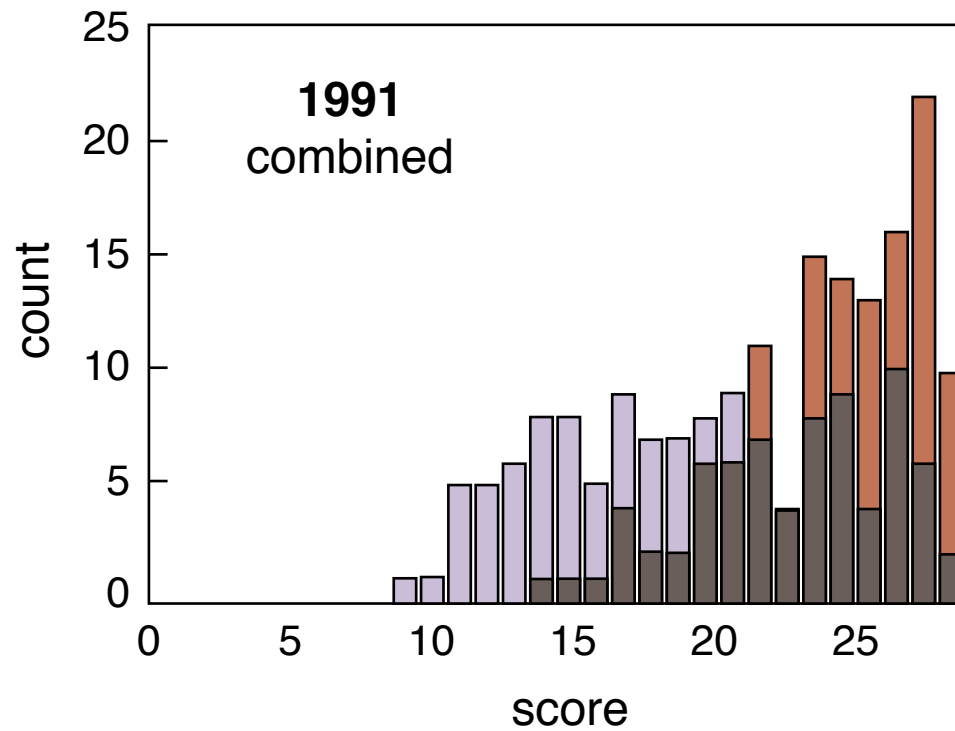

# Peer Instruction

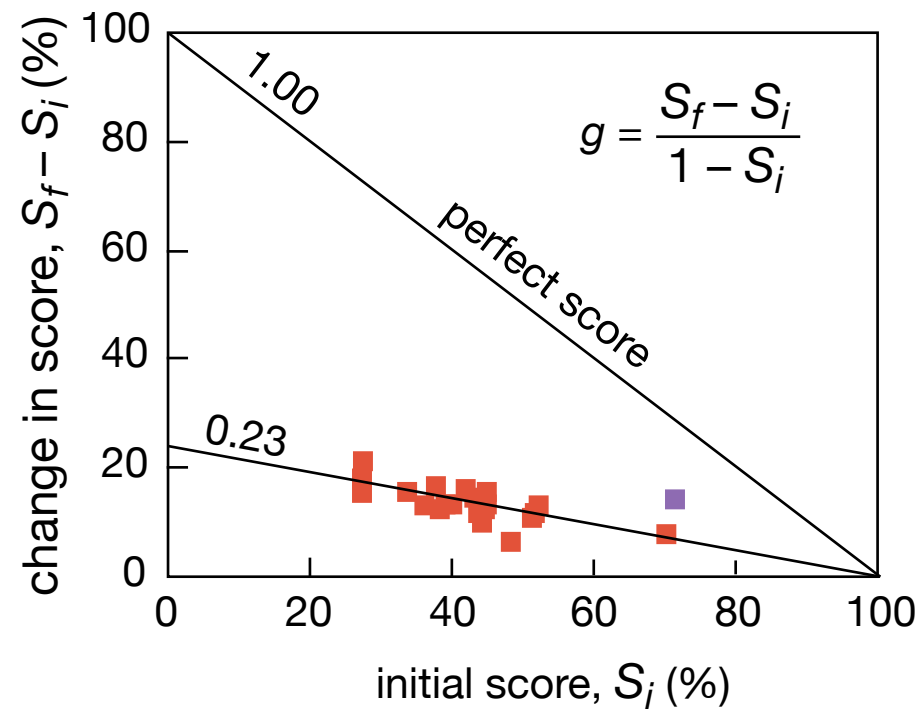

# Peer Instruction

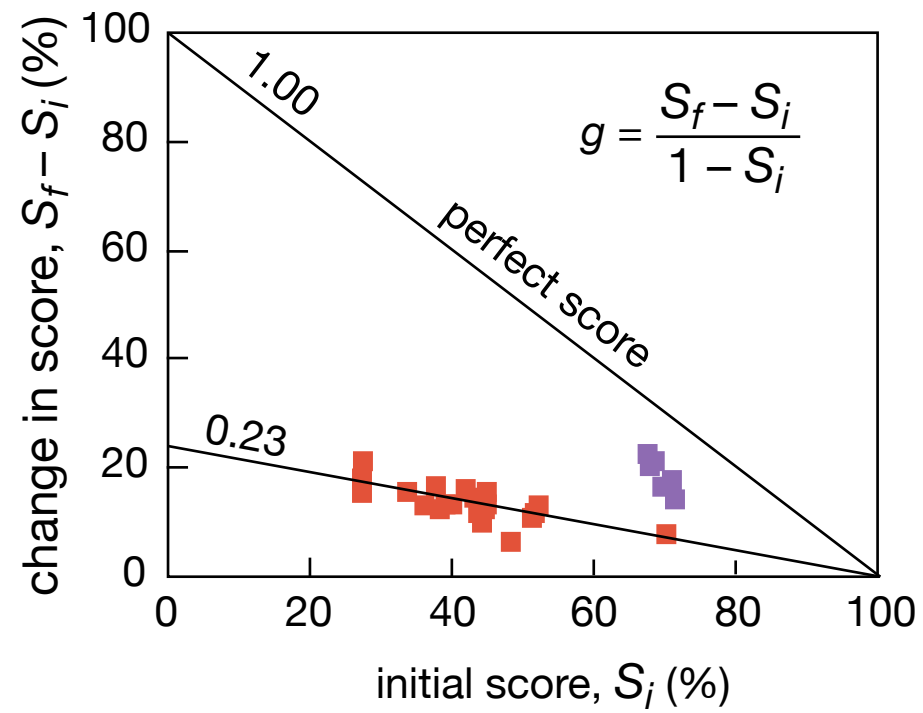

# Peer Instruction

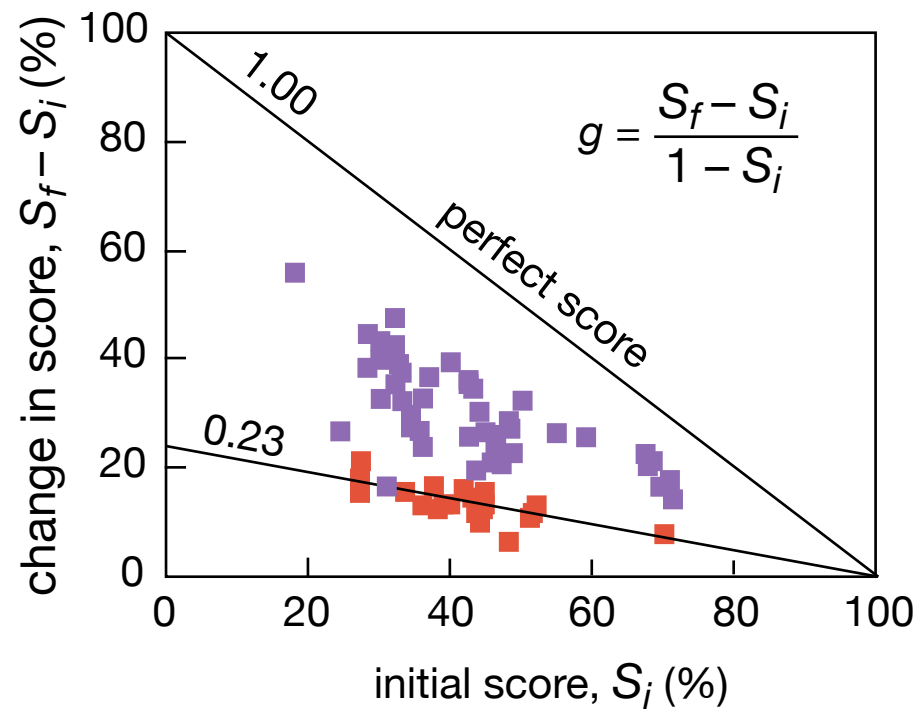

# Peer Instruction

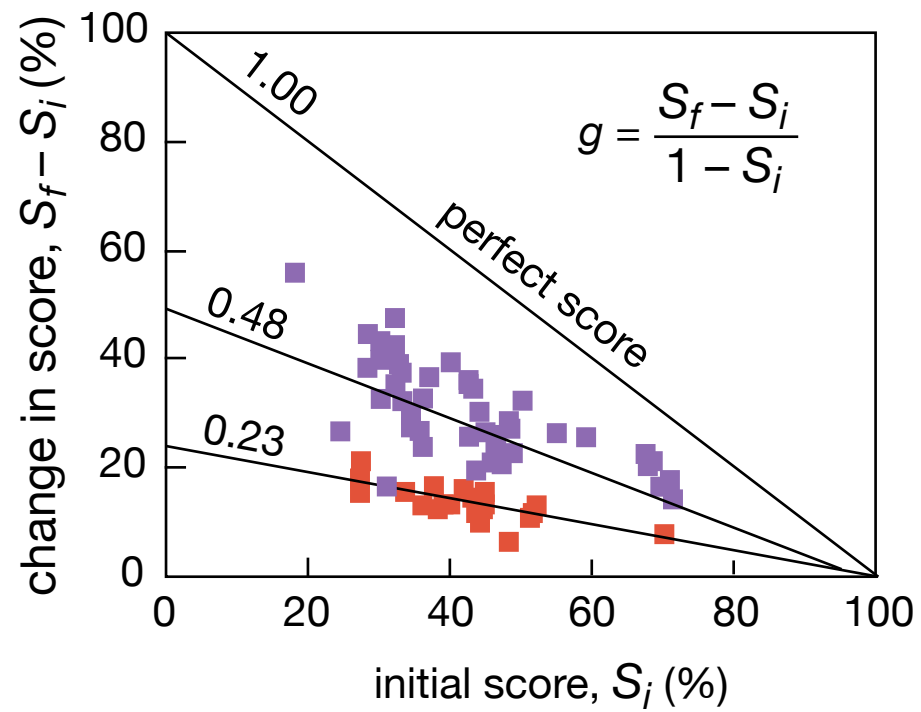

# Peer Instruction

**what about problem solving?**

# Peer Instruction

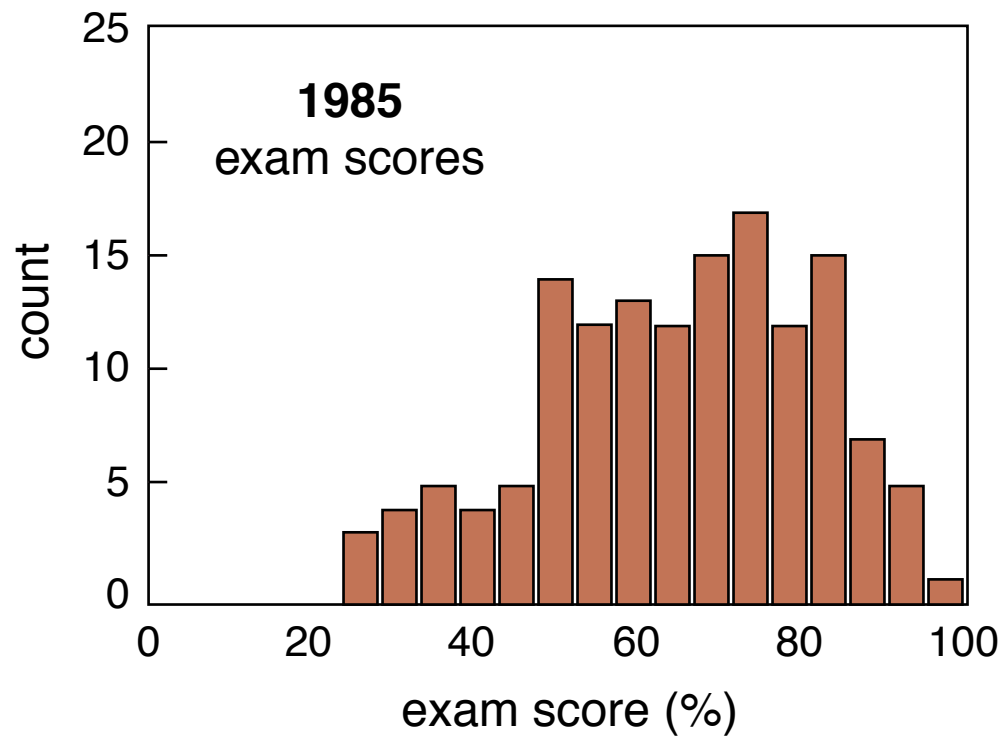



# Peer Instruction

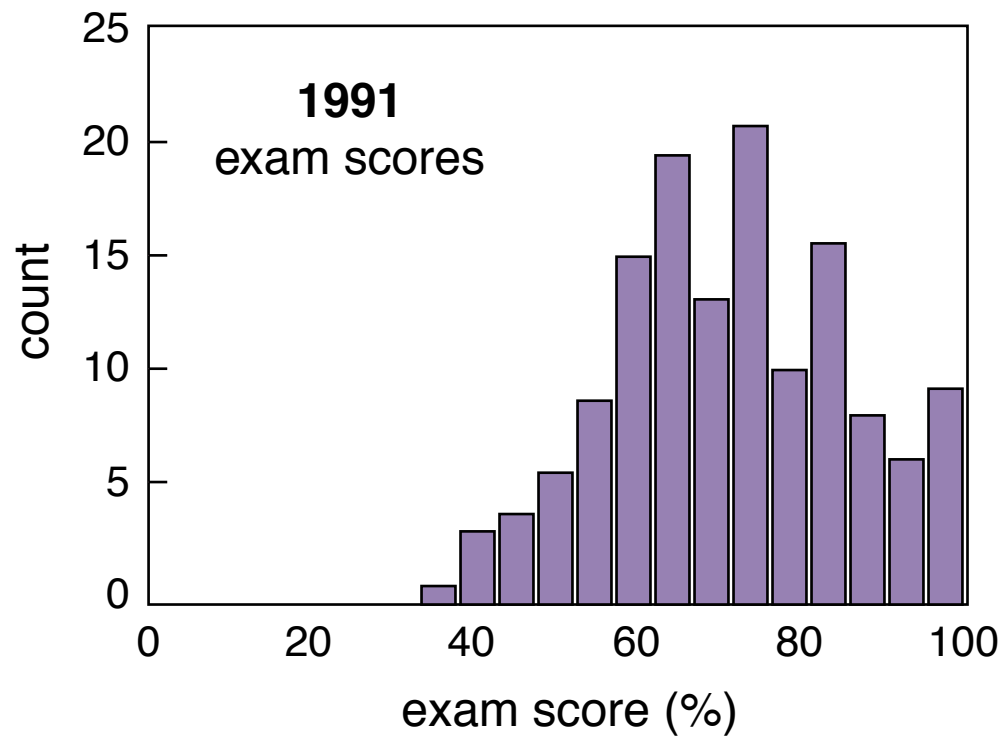

# Peer Instruction

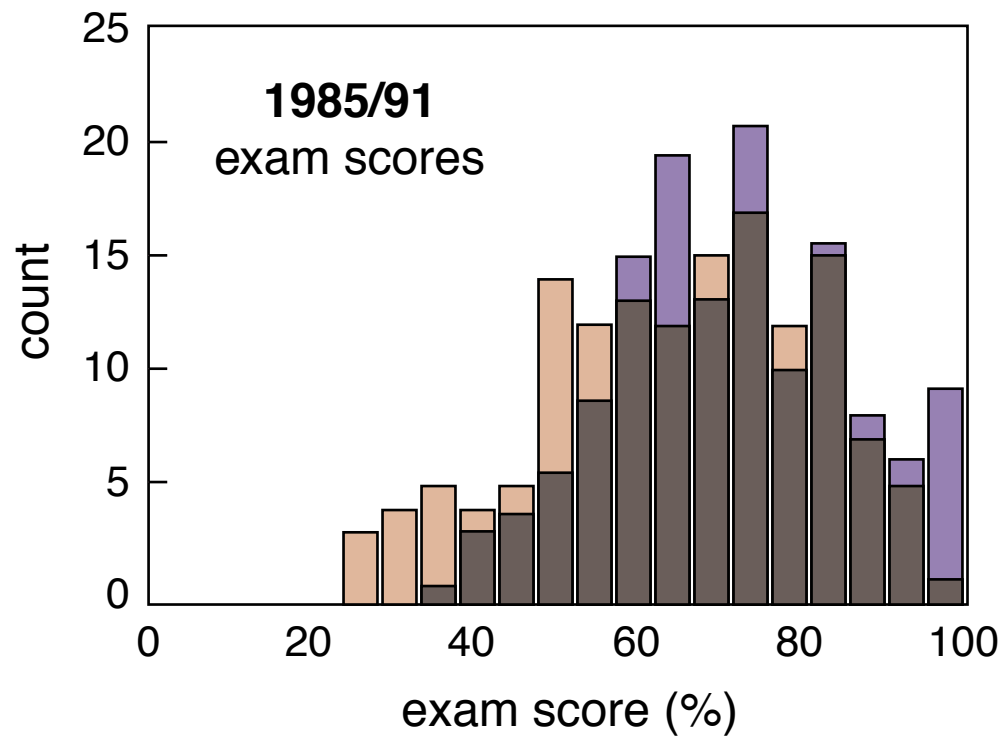

# Peer Instruction

**So better understanding leads to better  
problem solving!**

# Peer Instruction

**So better understanding leads to better problem solving!**

**(but “good” problem solving doesn’t always indicate understanding!)**



# Conclusion

Let's not forget the base  
of the pyramid

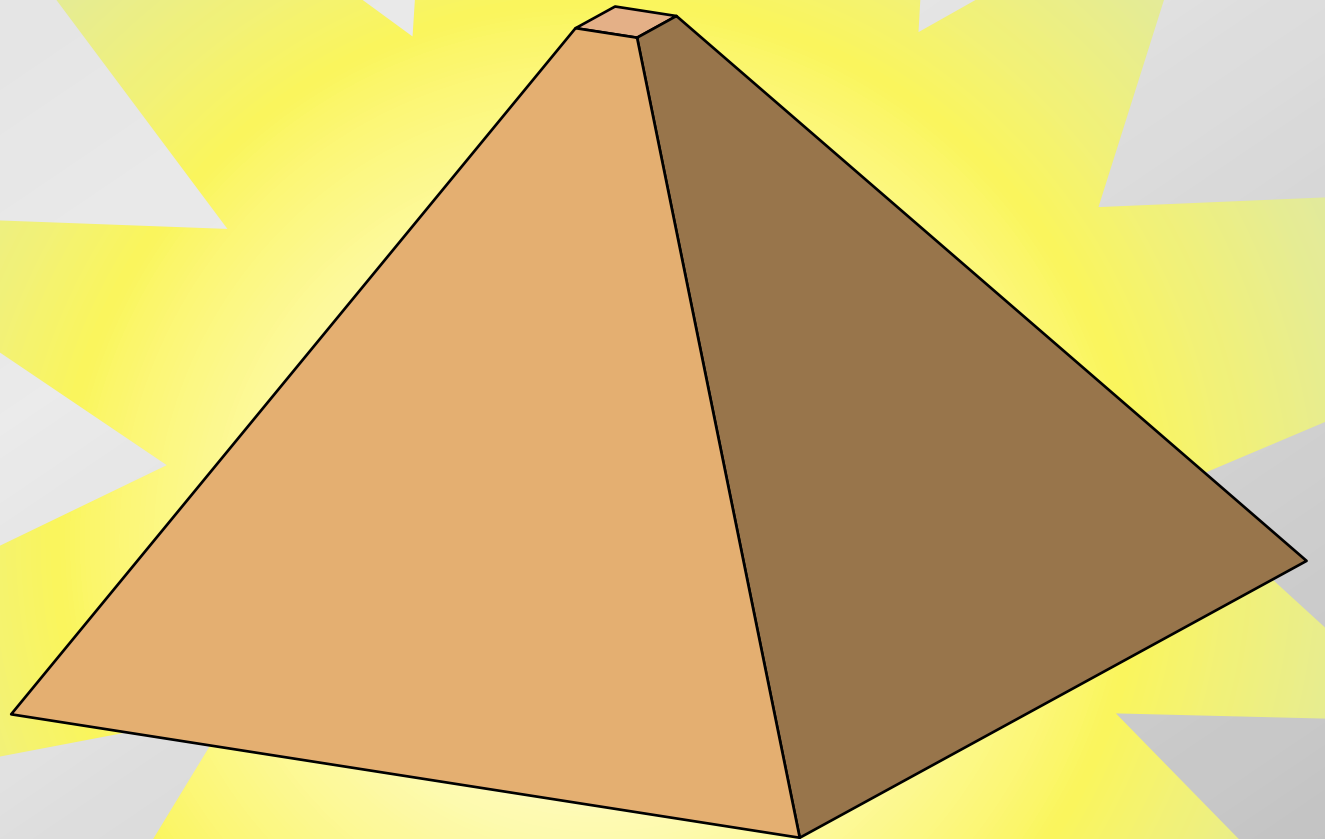

# Conclusion

Let's give them something  
of value!

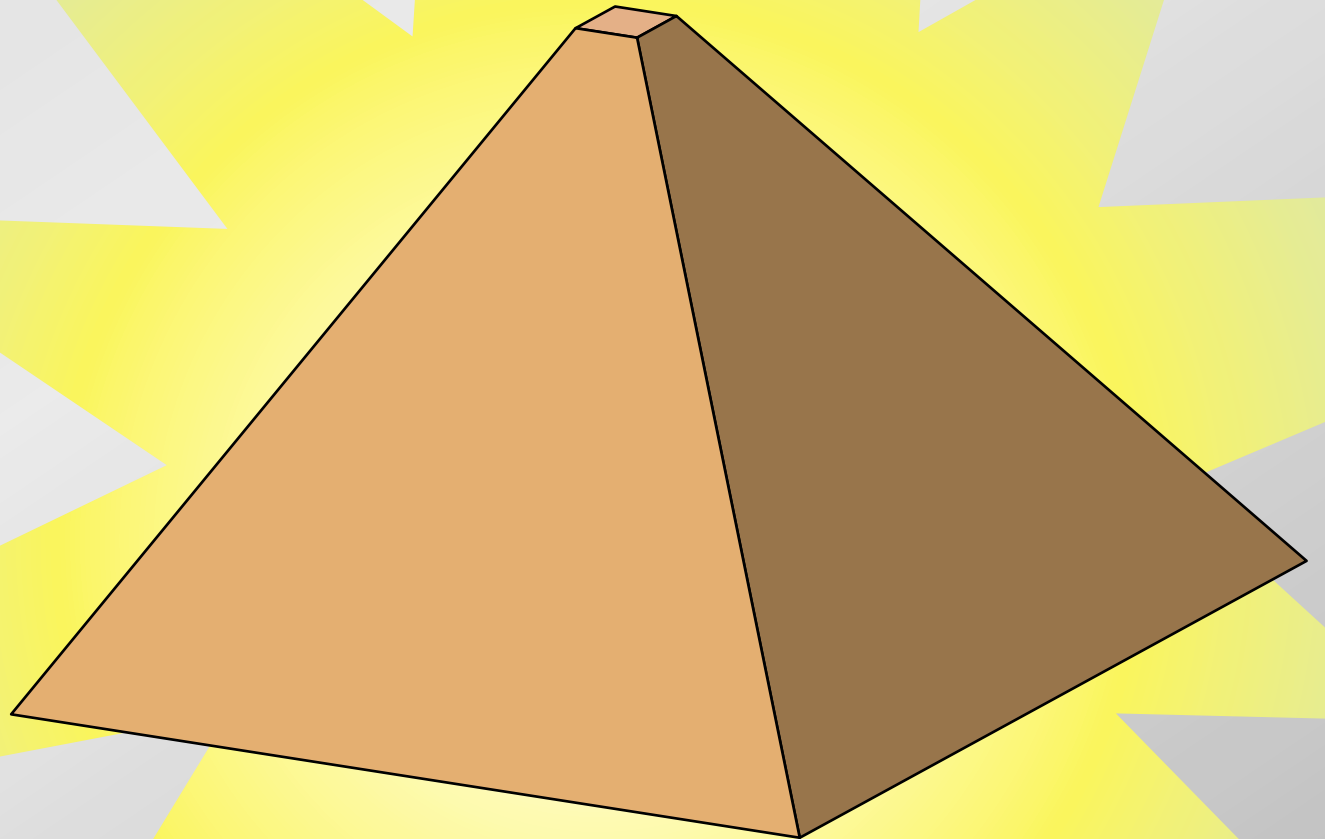

**Funding:**

**National Science Foundation**

**for a copy of this presentation:**

**<http://mazur-www.harvard.edu>**