

# Understanding or Memorization: Are we teaching the right thing?

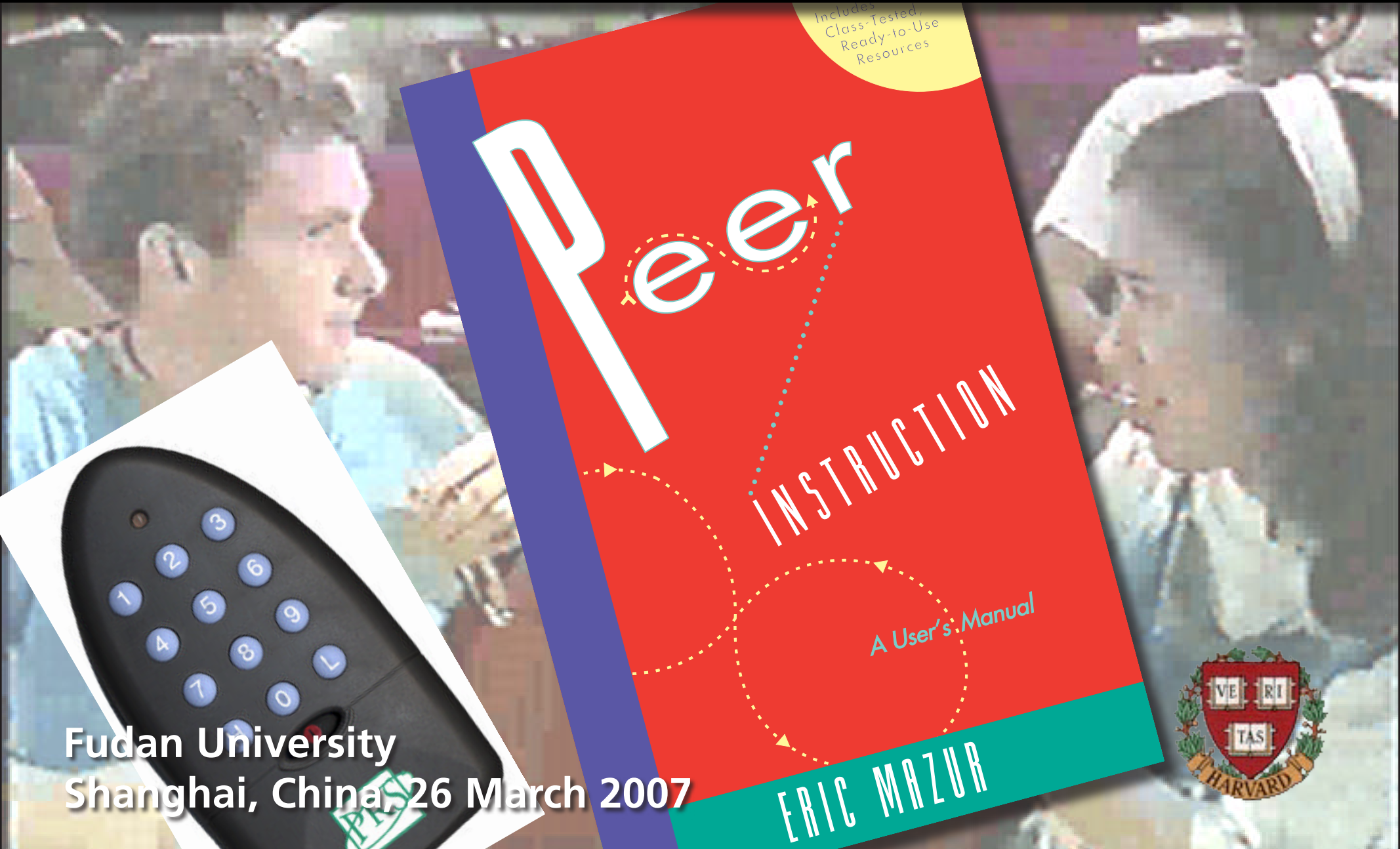

Fudan University  
Shanghai, China, 26 March 2007

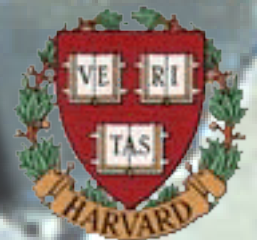

# My message

**shift focus from "teaching" to helping students learn**



# Outline

- Education



# Outline

- Education
- Peer Instruction



# Outline

- Education
- Peer Instruction
- Results





# Education



# Education

lectures focus on delivery of information

A wide-angle photograph of a large lecture hall. The room is filled with students seated at long desks, all facing towards the front. At the front of the room, a lecturer is standing at a podium, addressing the class. Behind the lecturer is a large projection screen displaying text. The walls are a light blue color, and the overall atmosphere is that of a formal educational setting.

# Education

education is not just information transfer

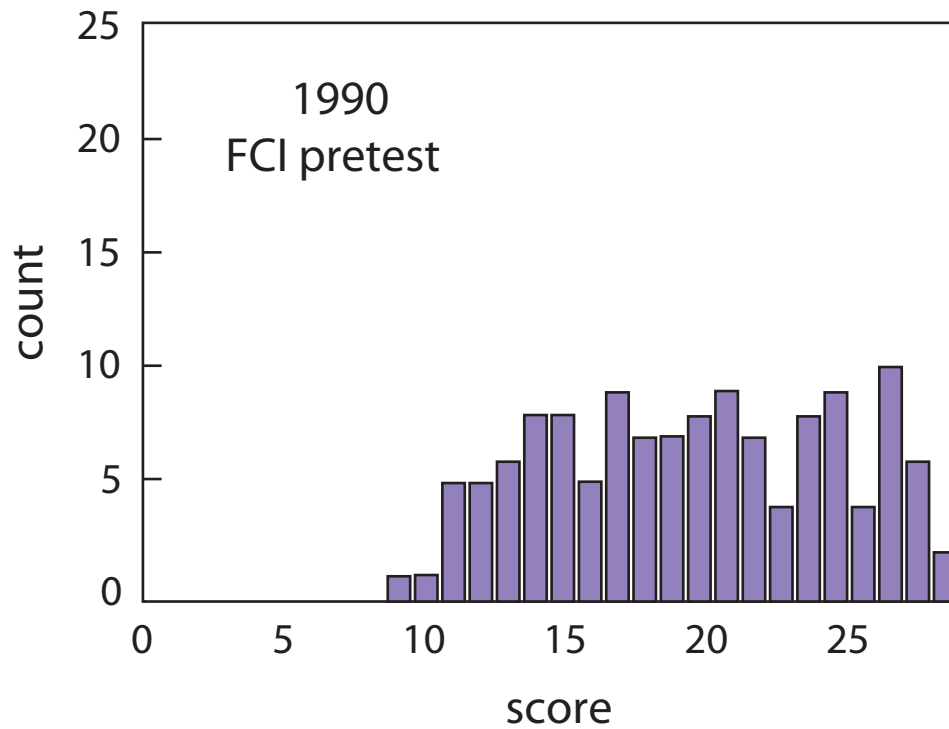



# Education

education is not just information transfer

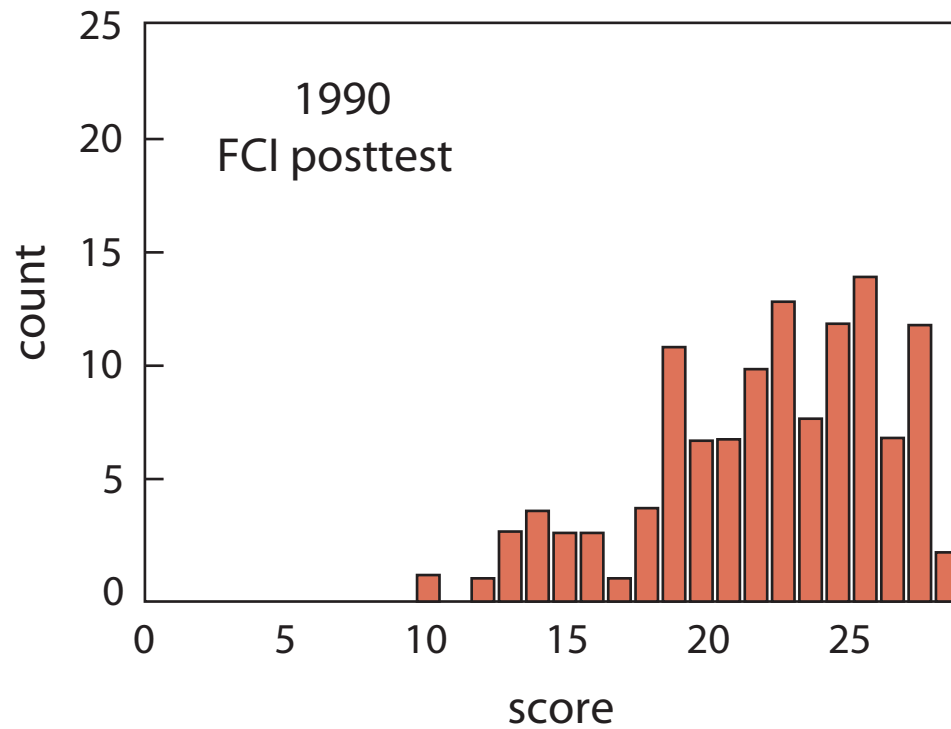

# Education

education is not just information transfer

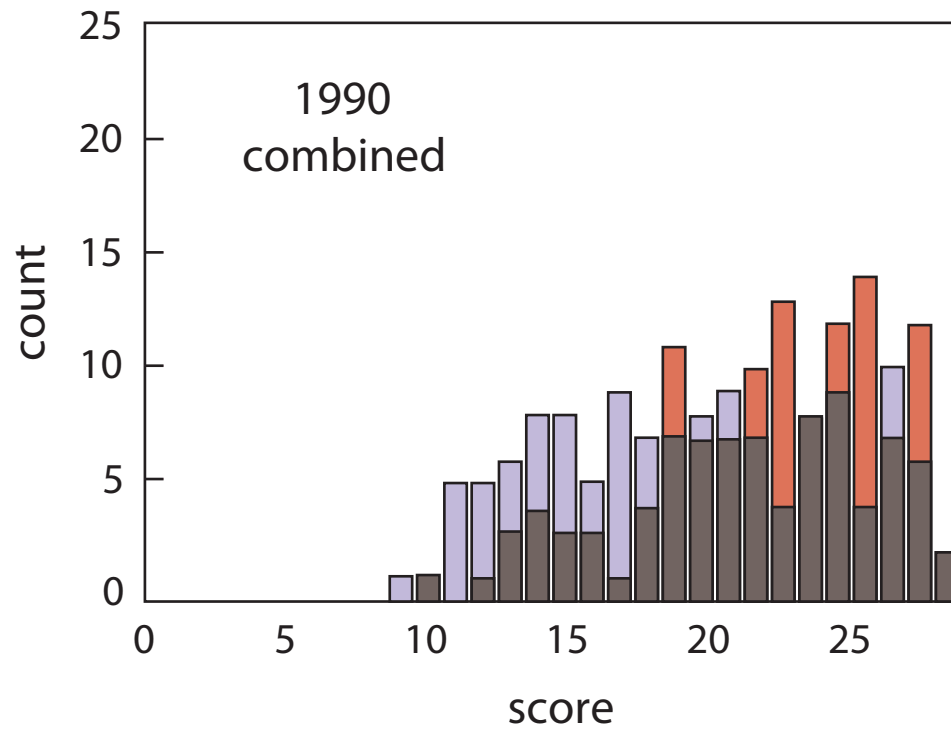

# Education

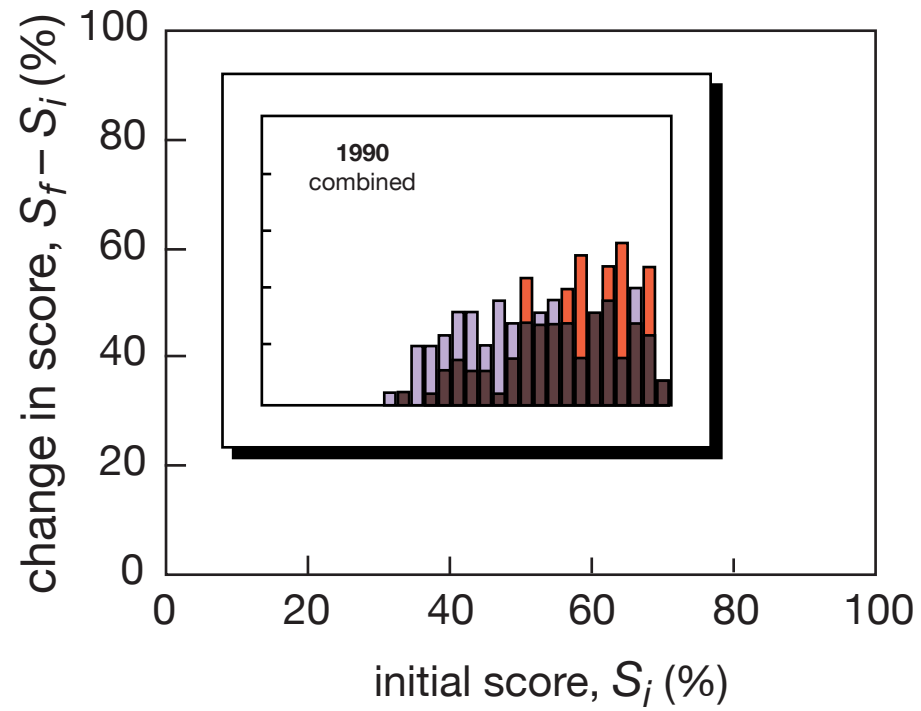

# Education

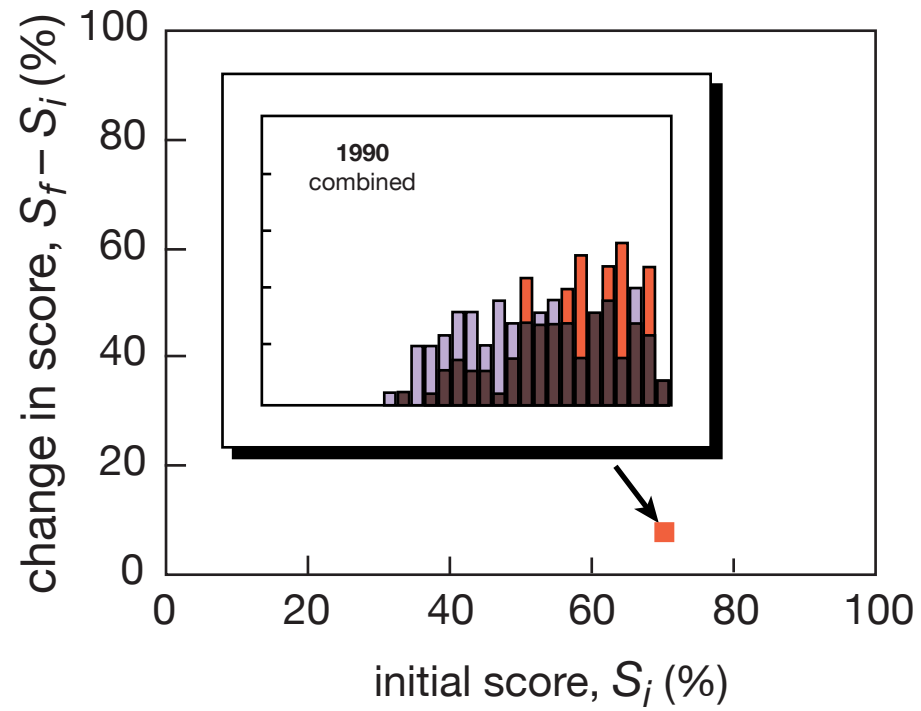

# Education

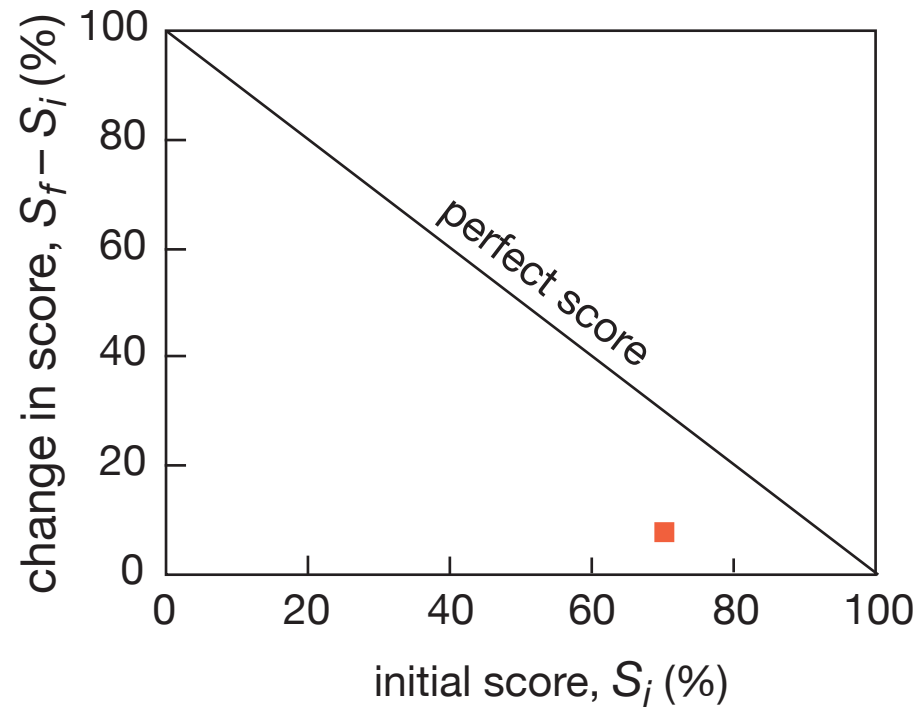



# Education

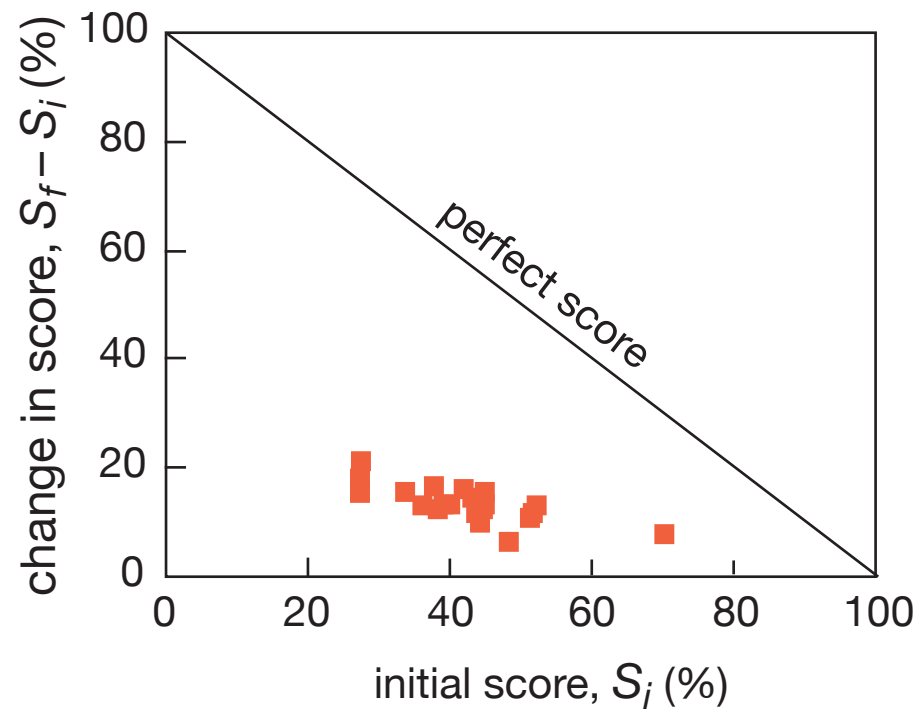

# Education

only one quarter of maximum gain realized

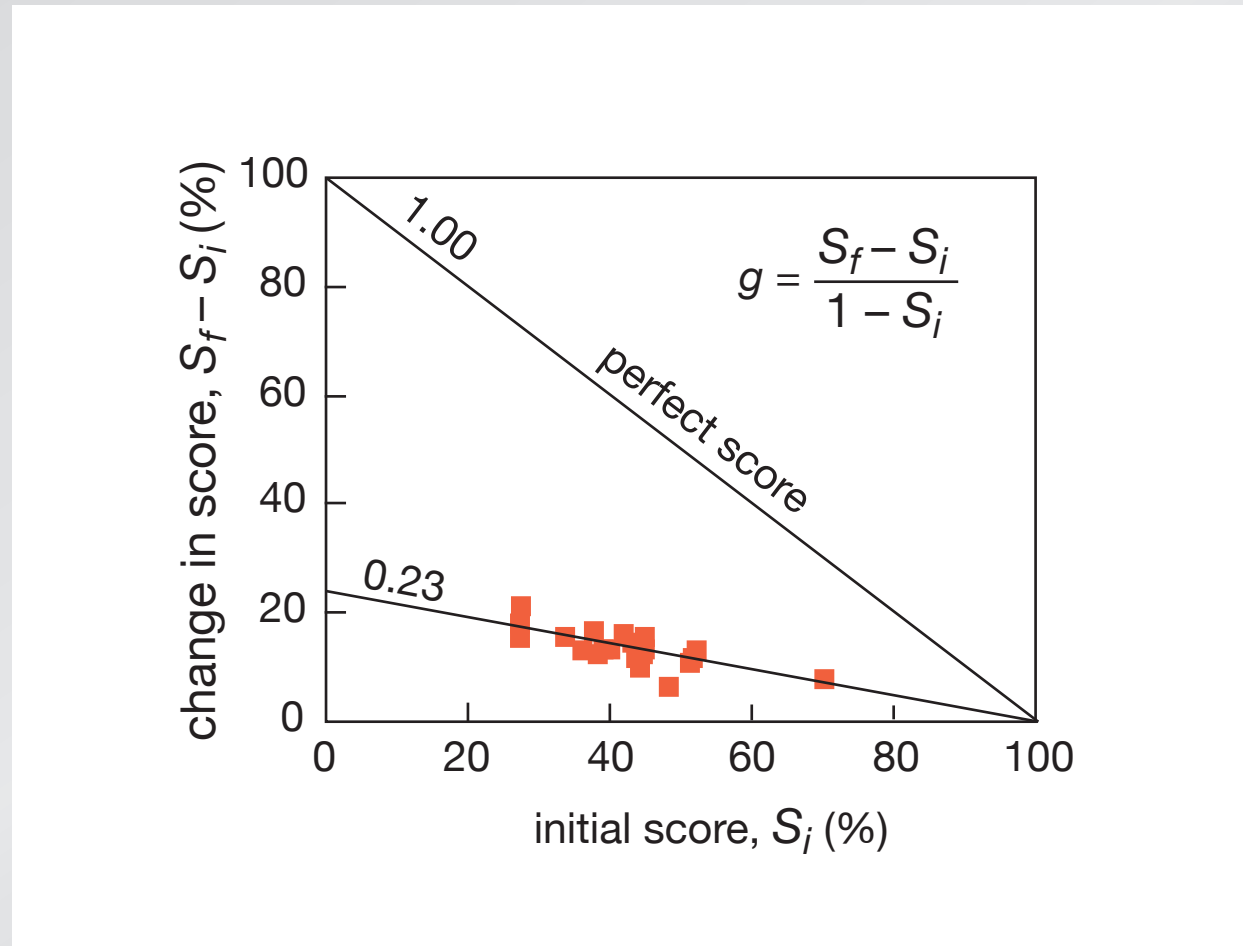

# Education

**not transfer but assimilation of information is key**

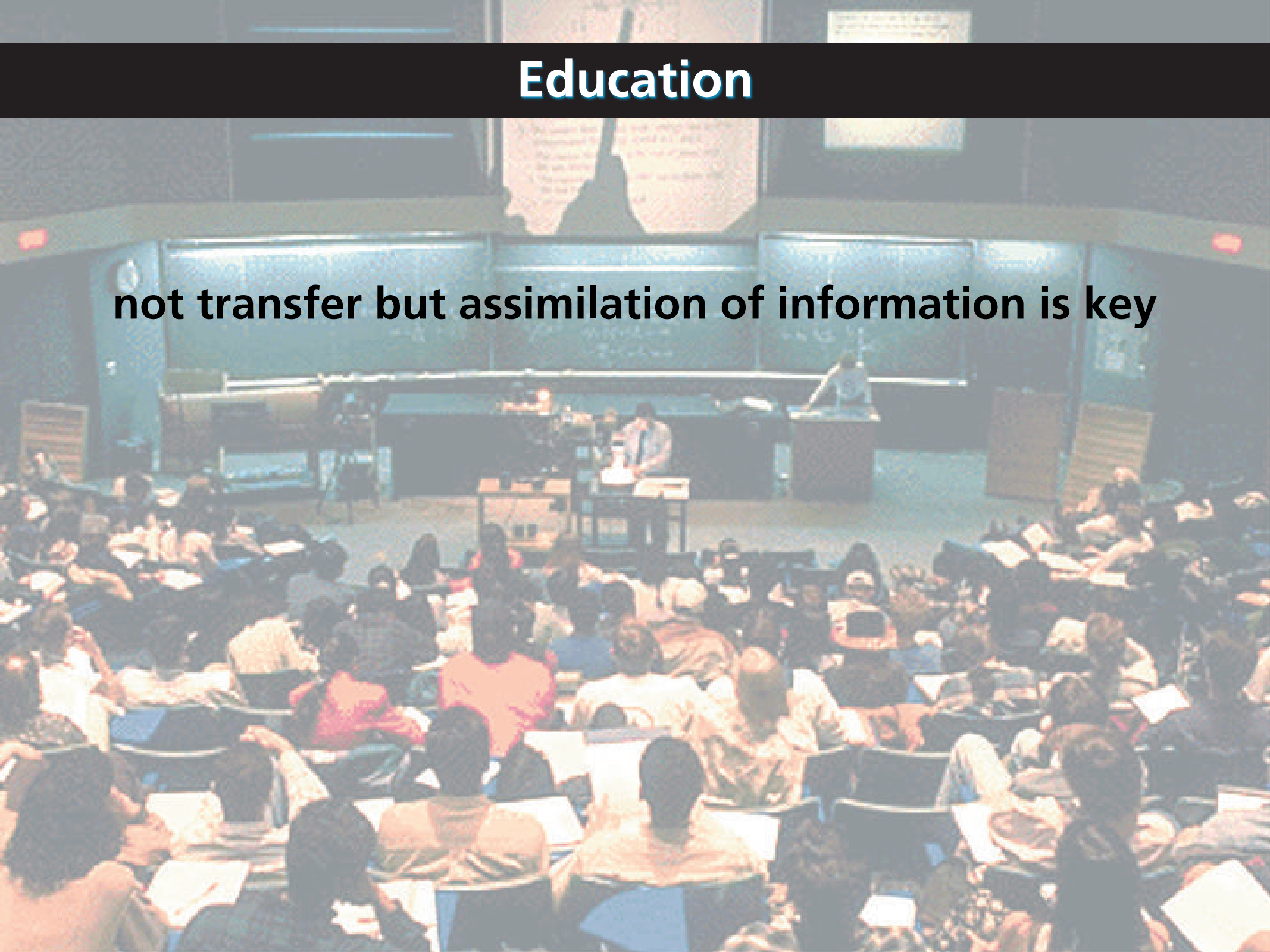

# Education

conventional problems misleading

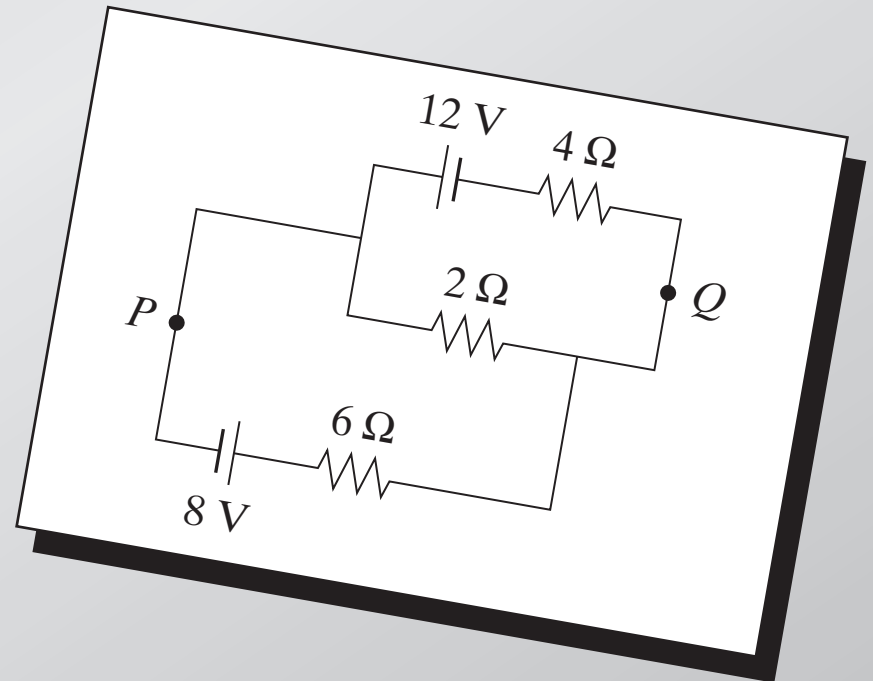

# Education

conventional problems misleading

Calculate:

(a) current in 2- $\Omega$  resistor

(b) potential difference

between  $P$  and  $Q$

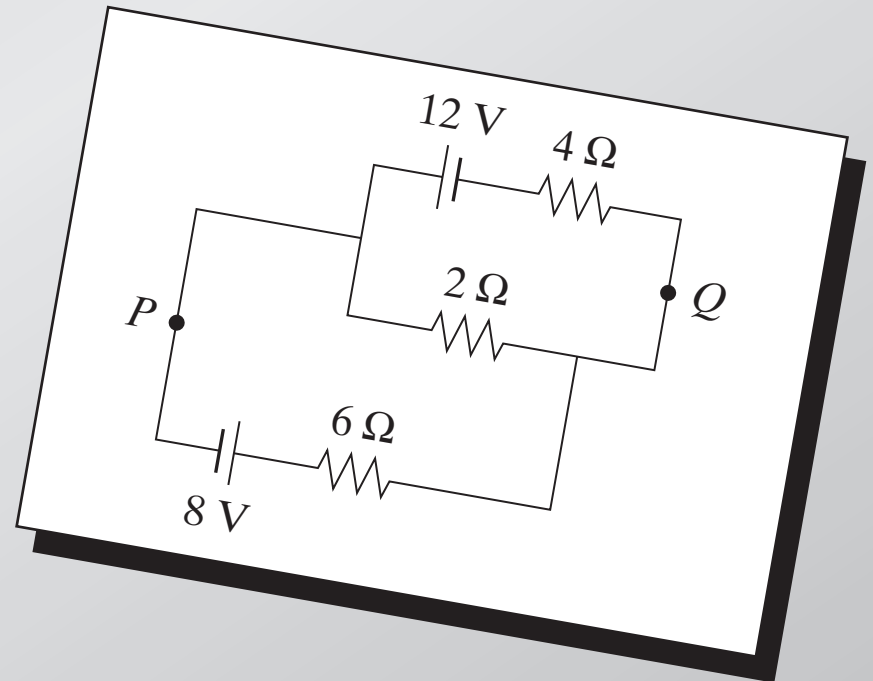



# Education

are the basic principles understood?

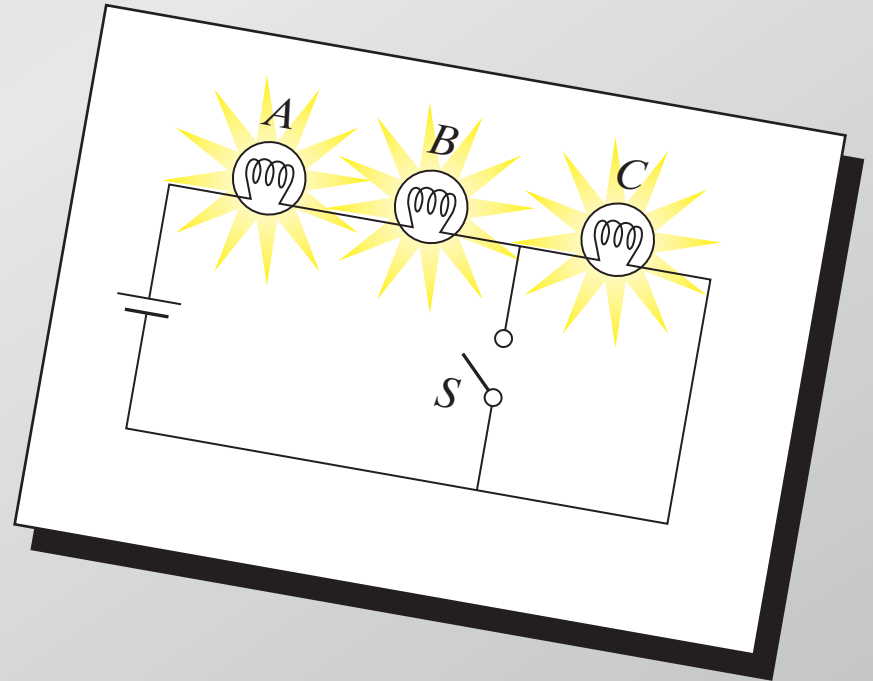

# Education

are the basic principles understood?

When  $S$  is closed, what happens to:

- (a) intensities of  $A$  and  $B$ ?
- (b) intensity of  $C$ ?
- (c) current through battery?
- (d) potential difference across  
 $A$ ,  $B$ , and  $C$ ?
- (e) the total power dissipated?

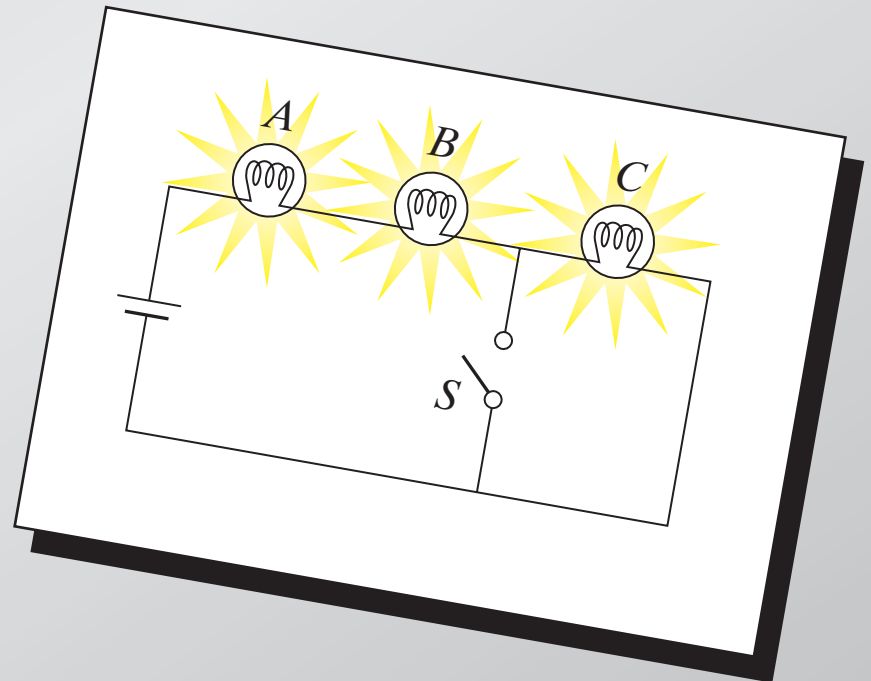

# Education

**conventional**

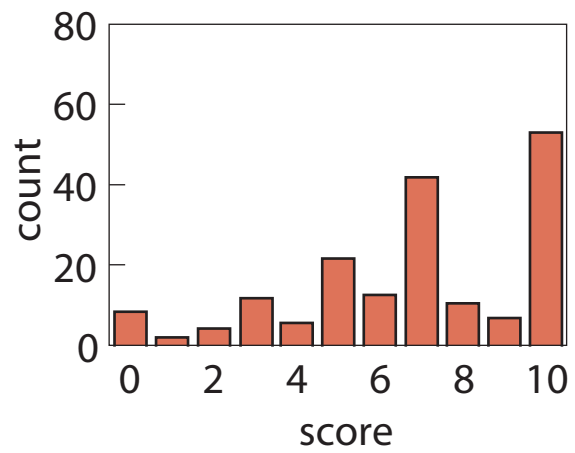

**conceptual**

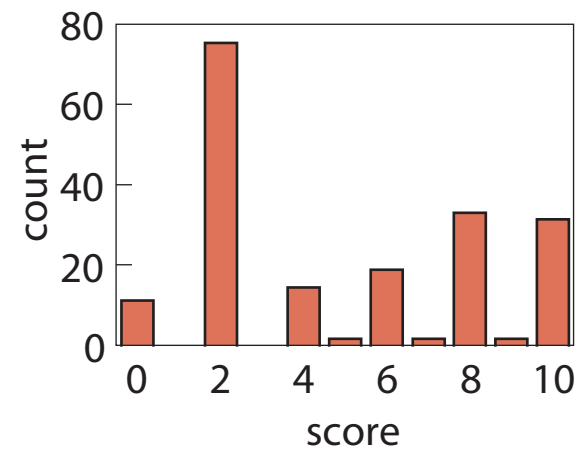

# Education

## conventional

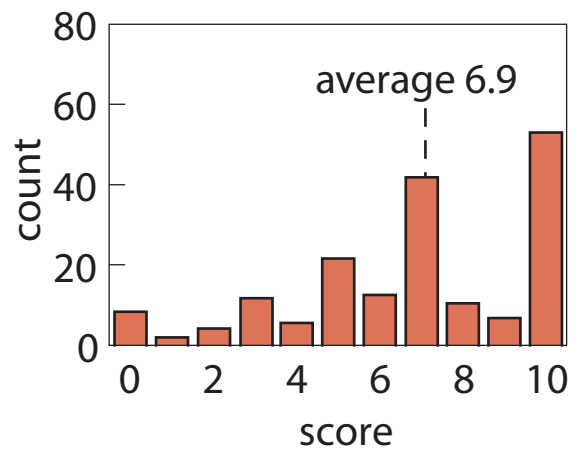

## conceptual

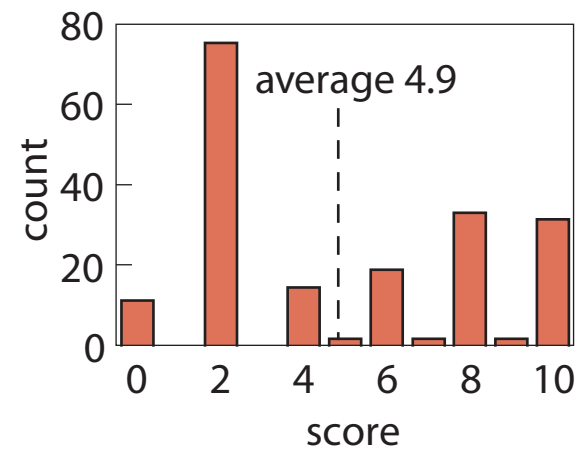

# Education

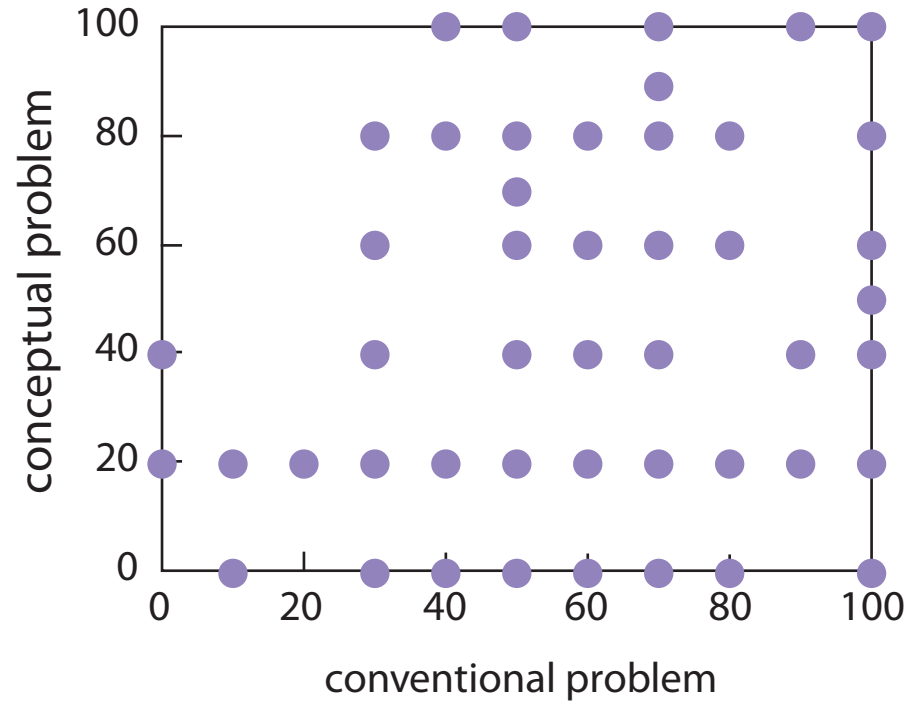



# Education

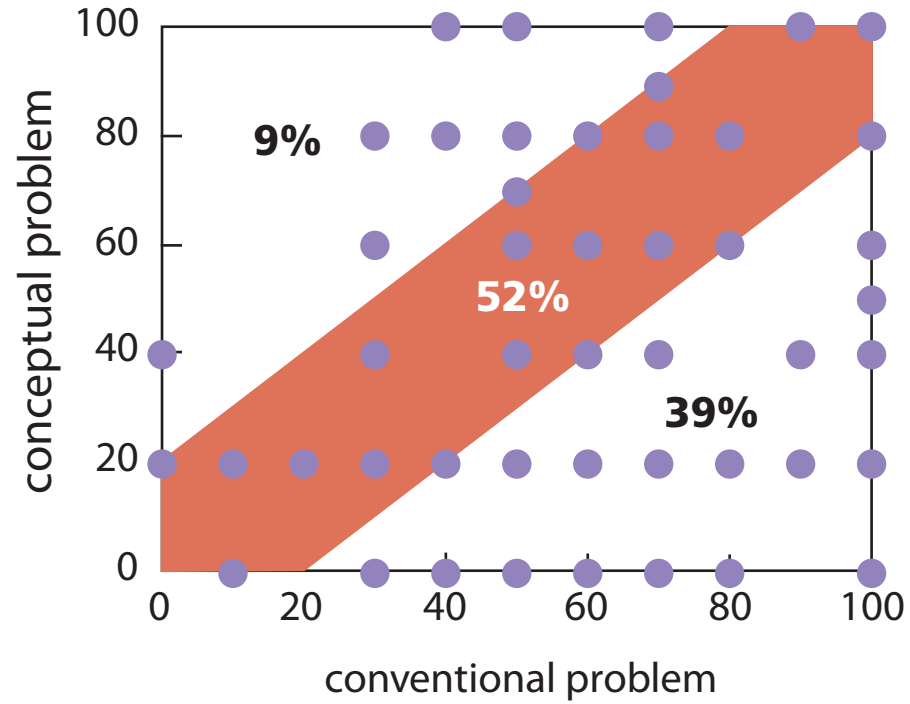

A large lecture hall with a professor at a podium and students seated at desks. A large screen at the front displays text and a diagram. The text on the screen is partially legible and includes the words "The world is full of..." and "The world is full of...".

So what should we do?

# Peer Instruction

**Give students more responsibility for gathering information...**

# Peer Instruction

**Give students more responsibility for gathering information...  
so we can better help them assimilate it.**

# Peer Instruction

## Main features:

- pre-class reading
- in-class: depth, not 'coverage'
- ConcepTests

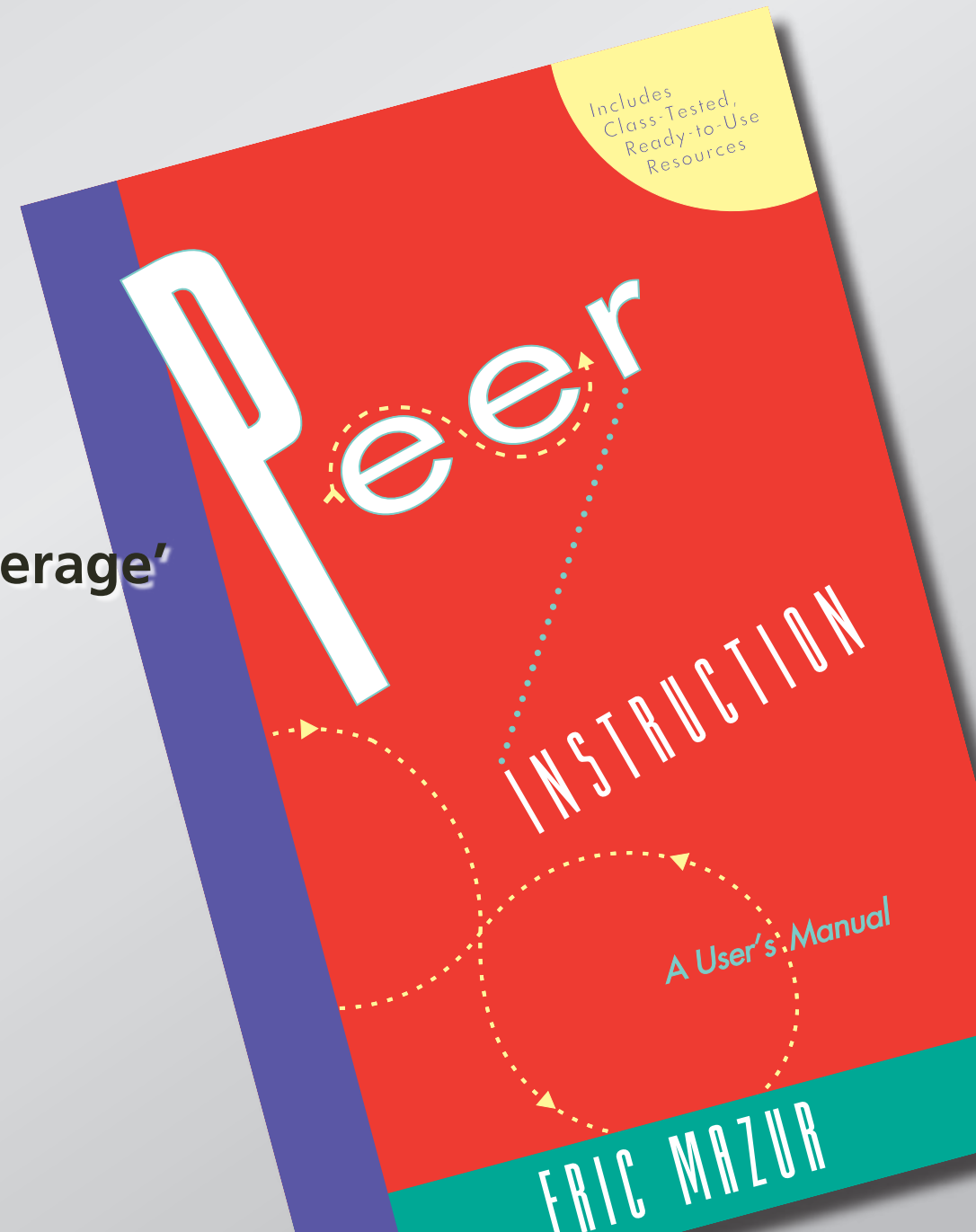

# Peer Instruction

**ConcepTest:**

- 1. Question**
- 2. Thinking**
- 3. Individual answer**
- 4. Peer discussion**
- 5. Revised/Group answer**
- 6. Explanation**



# Results

**is it any good?**



# Results

## first year of implementing PI

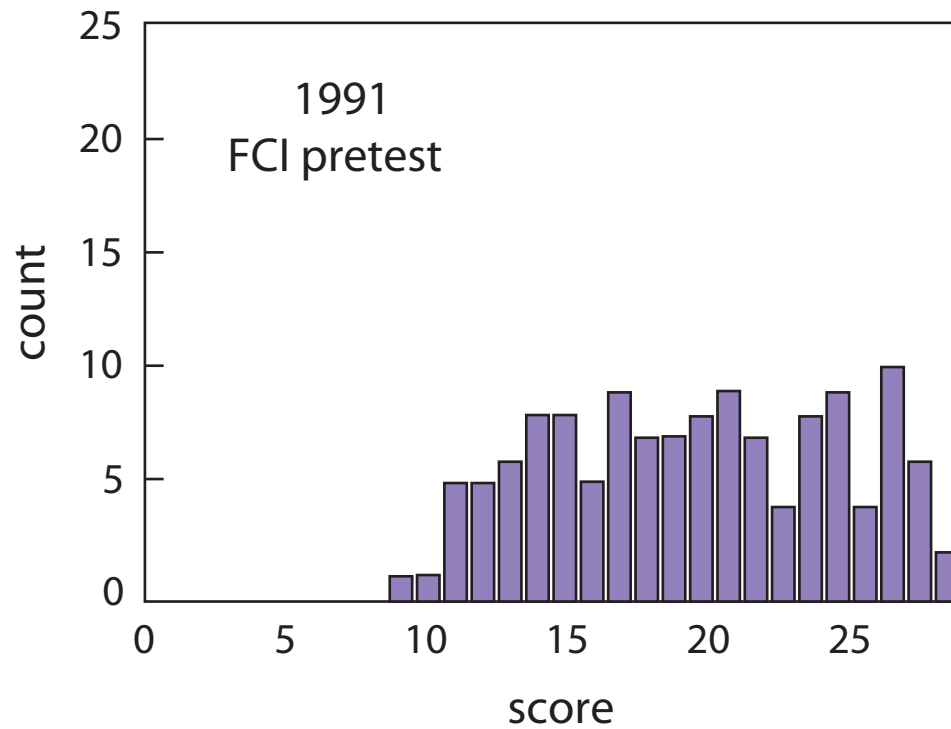

# Results

## first year of implementing PI

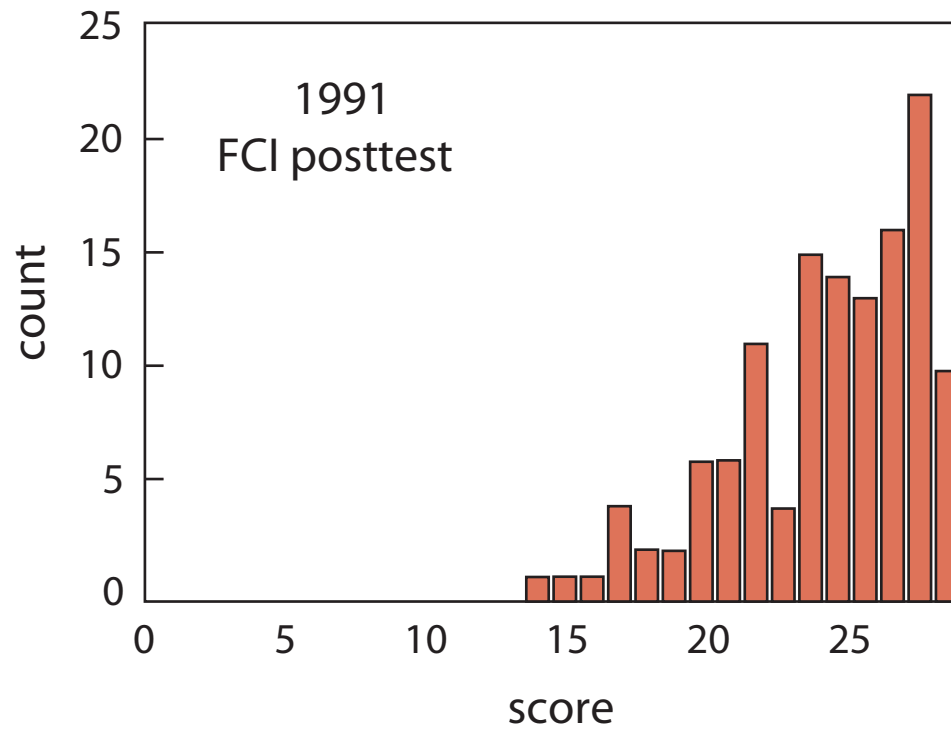

# Results

## first year of implementing PI

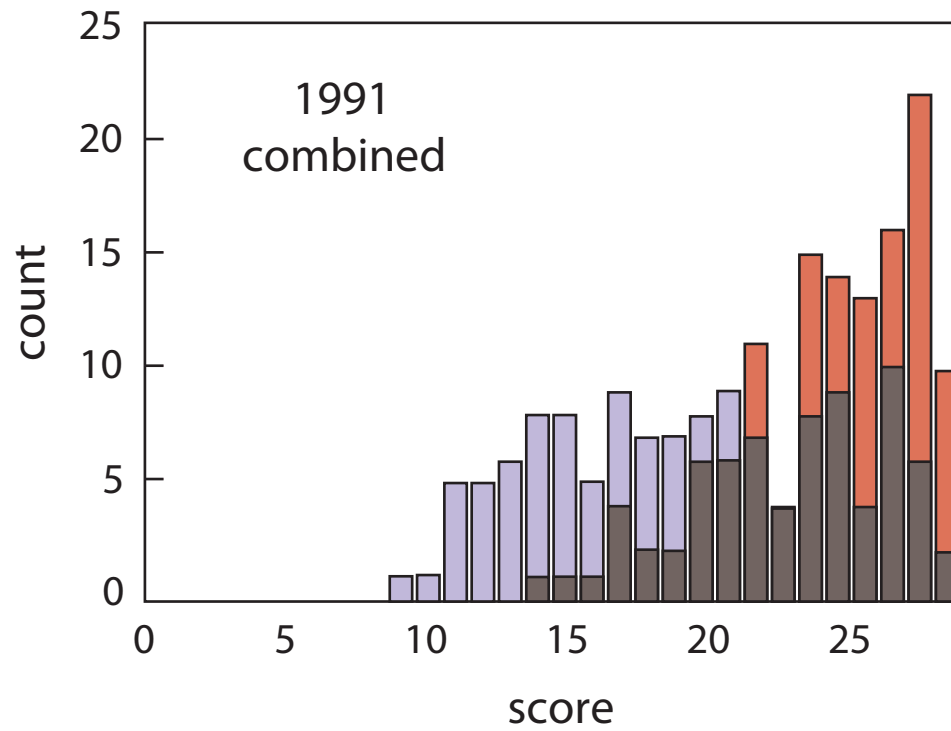

# Results

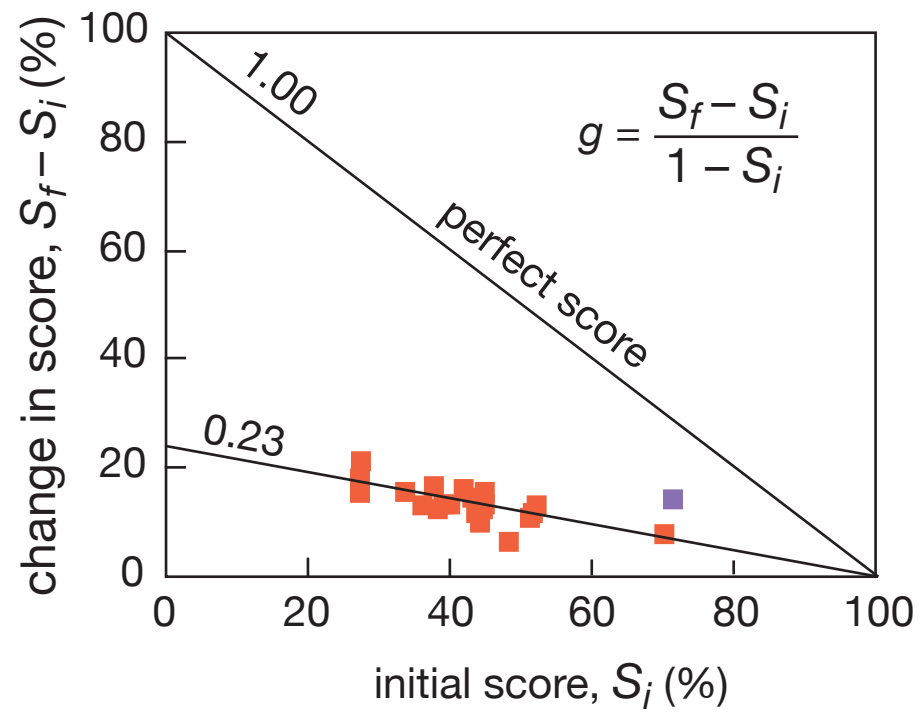

# Results

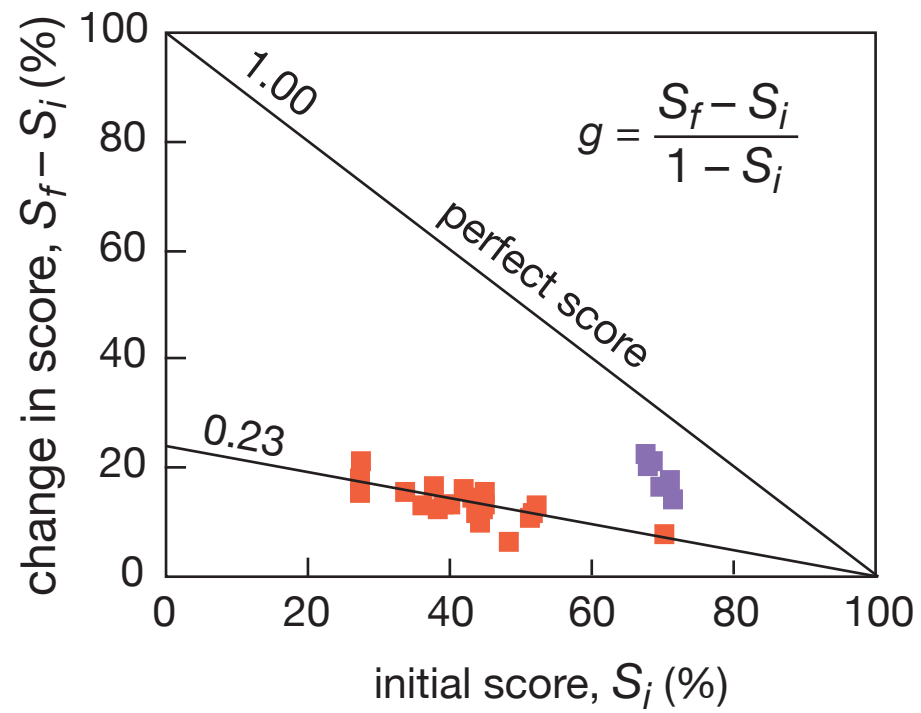

# Results

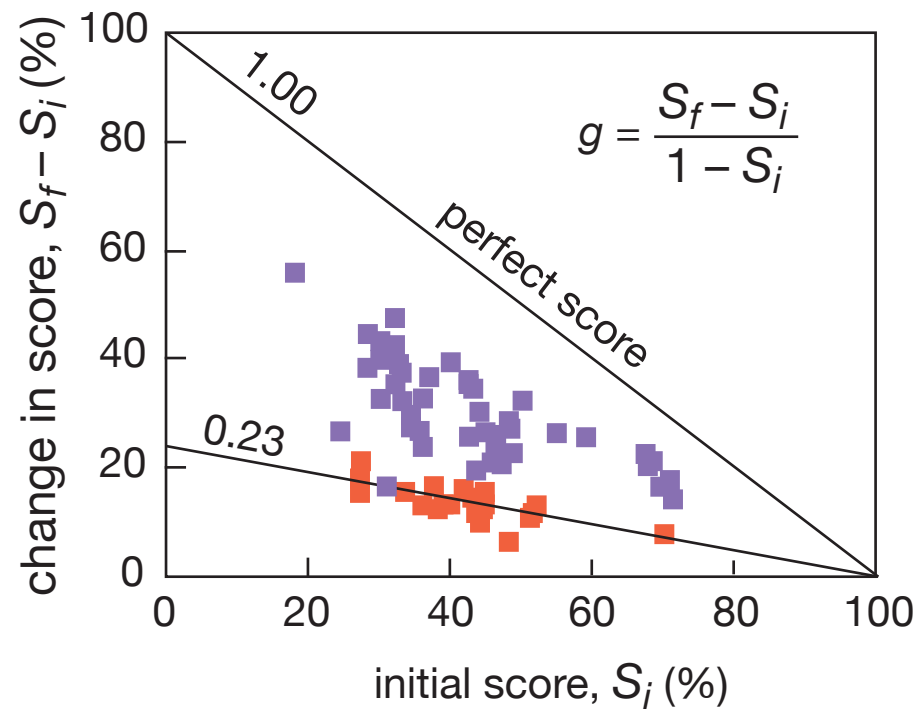

# Results

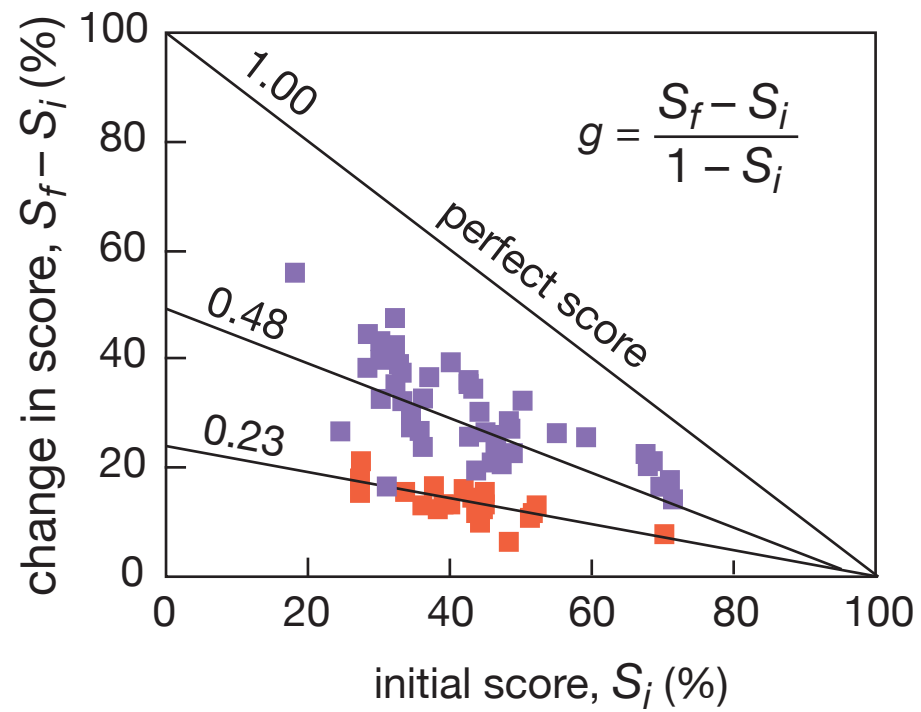

# Results

**what about problem solving?**



# Results

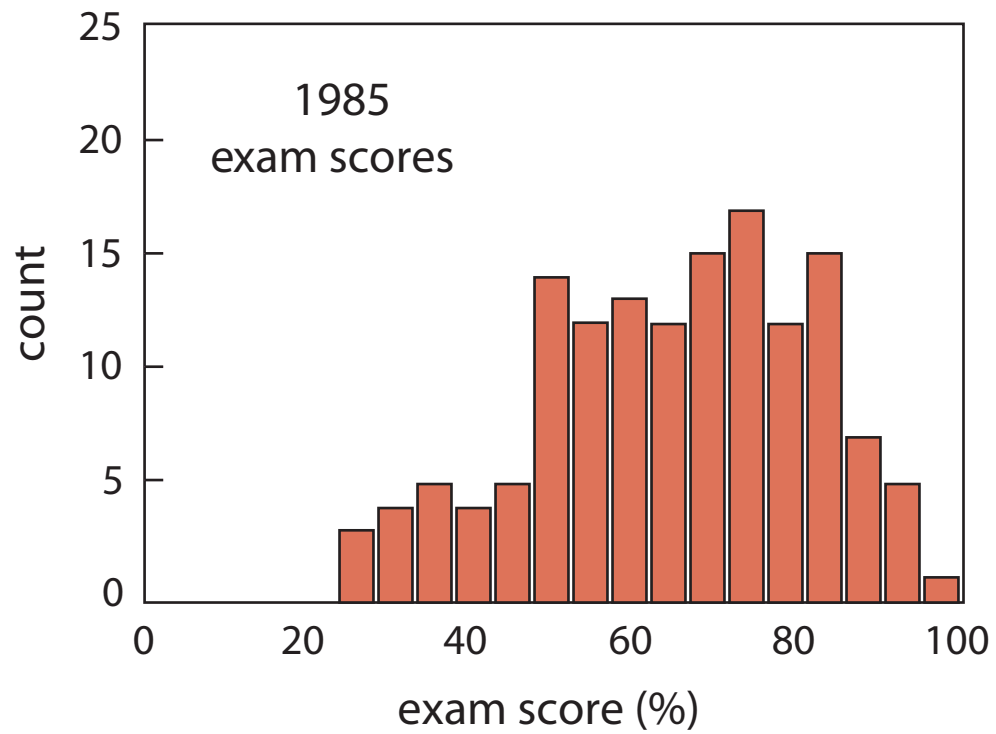

# Results

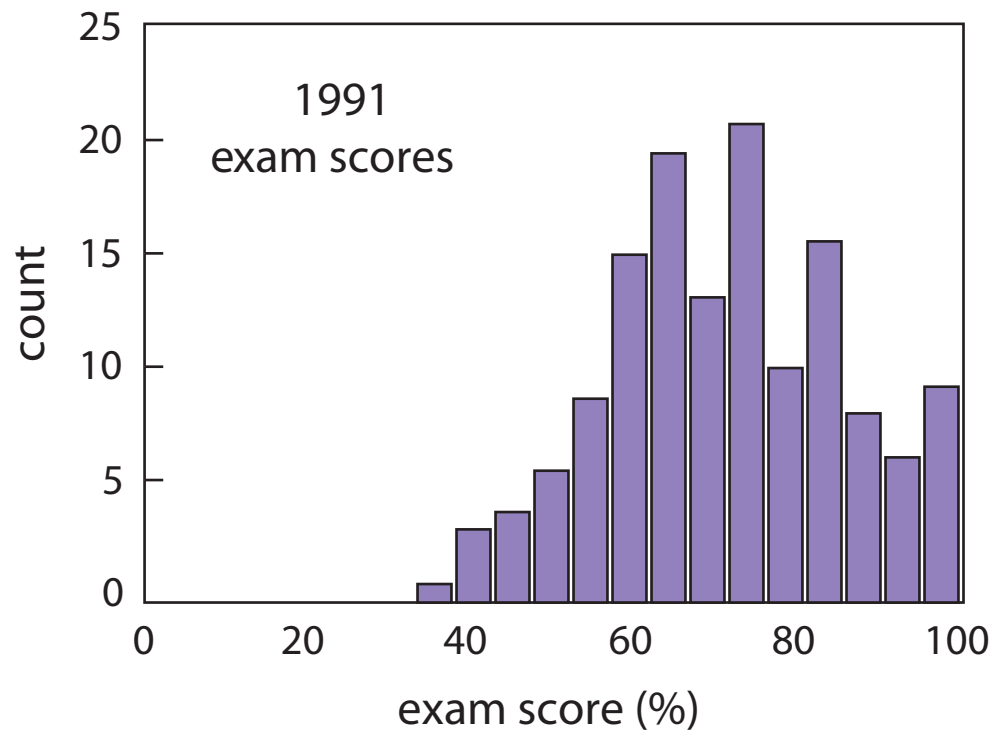

# Results

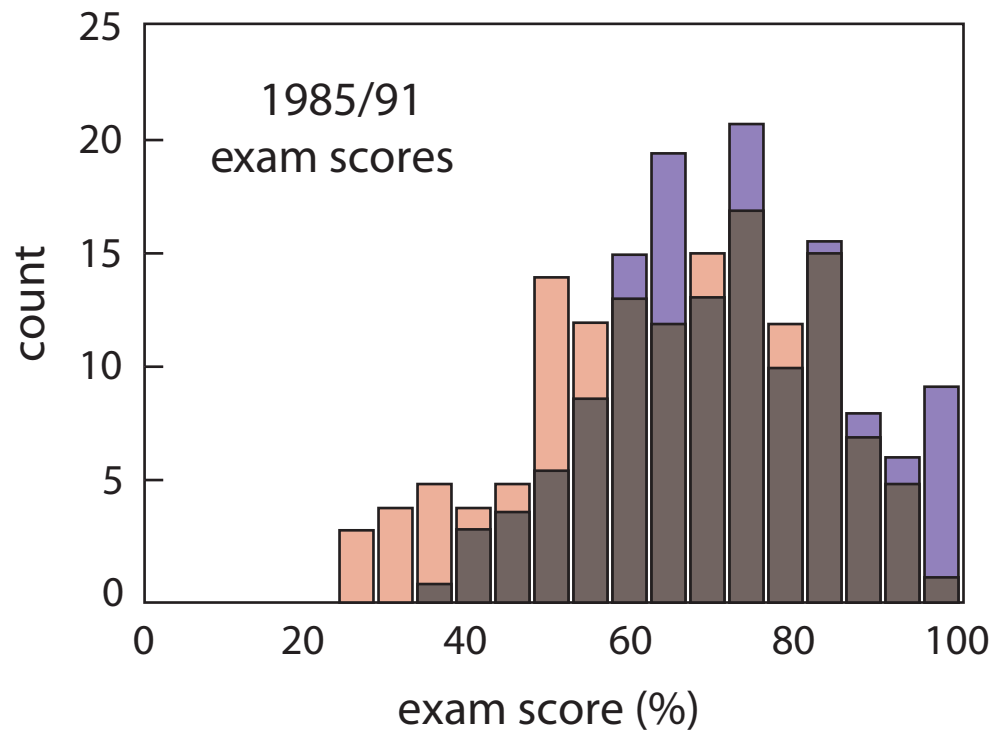

# Summary

**So better understanding leads to better  
problem solving!**

# Summary

**So better understanding leads to better problem solving!**

**(but “good” problem solving doesn’t always indicate understanding!)**



**Funding:**

**National Science Foundation**

**for a copy of this presentation:**

**<http://mazur-www.harvard.edu>**