

The world experienced a fatal error!



## CRÍTICA DO CONTEMPORÂNEO

CONFERÊNCIAS INTERNACIONAIS

Coordenador: Rui Mota Cardoso  
AUDITÓRIO DE SERRALVES

POLÍTICA/EDUCAÇÃO/BIOLOGIA  
MAR-DEZ 2007

## Educação

Comissário: Manuel Costa  
Moderador: Alberto Amaral

**15 MAI** (Ter), 21h30  
**ERIC MAZUR (EUA)**

“Alunos no papel de professores”

[www.serralves.com](http://www.serralves.com)

OK

DESIGN GRÁFICO: ASSESSORIA DE IMAGEM  
E DIVULGAÇÃO DA FUNDAÇÃO DE SERRALVES

Rua D. João de Castro, 210  
4150-417 Porto, Portugal  
Tel: 226 156 571 . Fax 226 156 597  
[www.serralves.pt](http://www.serralves.pt) | [serralves@serralves.com](mailto:serralves@serralves.com)

FUNDAÇÃO SERRALVES

APOIO INSTITUCIONAL



Projecto Co-Financiado pela União Europeia/FEDER



Apoio



UNIÃO EUROPEIA

Fundação do Desenvolvimento Regional

1989 FUNDAÇÃO 2005

LUSO-AMERICANA

# Confessions of a converted lecturer



Crítica do Contemporâneo, Conferências Internacionais  
Fundação Serralves  
Porto, Portugal, 15 May 2007



# My message

**shift focus from "teaching" to helping students learn**

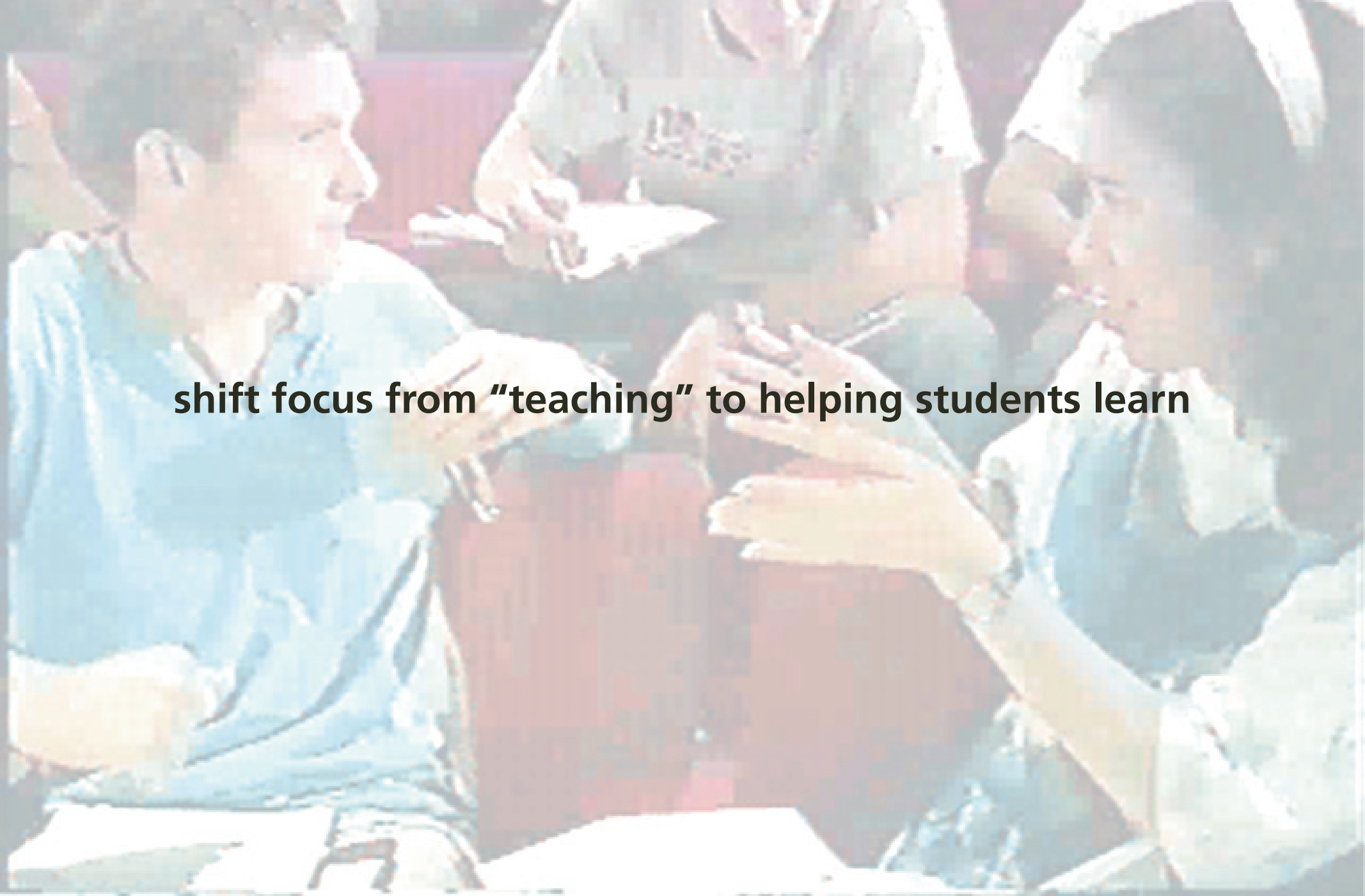

# Outline

- Education



# Outline

- Education
- Peer Instruction



# Outline

- Education
- Peer Instruction
- Results



# Education



# Education

lectures focus on delivery of information

A large lecture hall with students seated at desks, facing a stage where a lecturer is presenting. A large screen displays text and a map. The room is filled with students, and the lecturer is standing at a podium on the stage. The screen shows a map of the world and some text.



# Education

education is not just information transfer

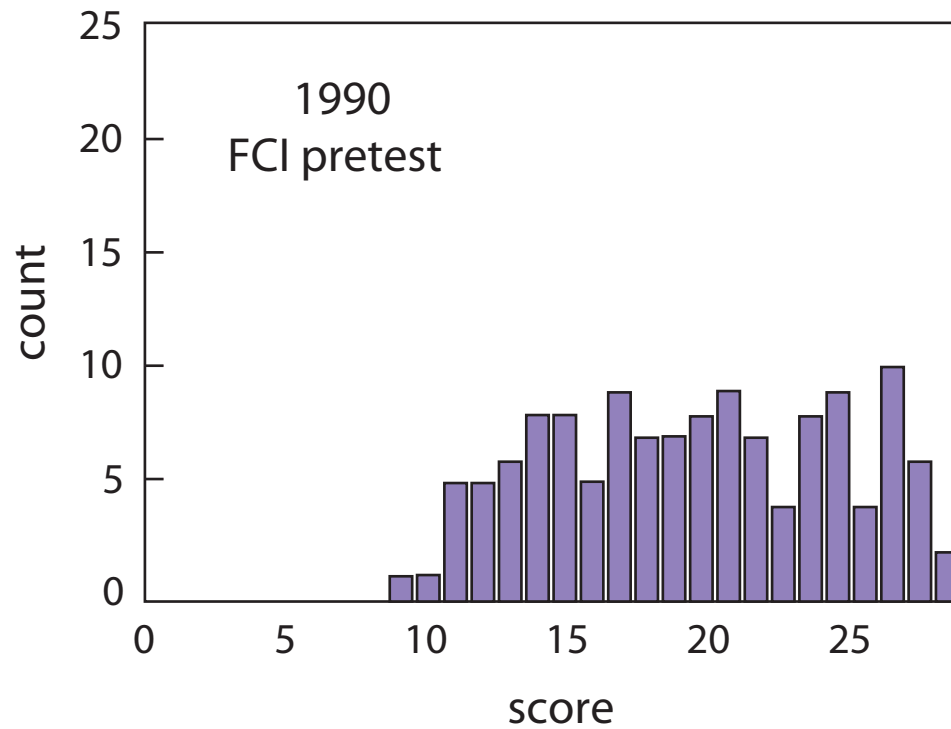

# Education

education is not just information transfer

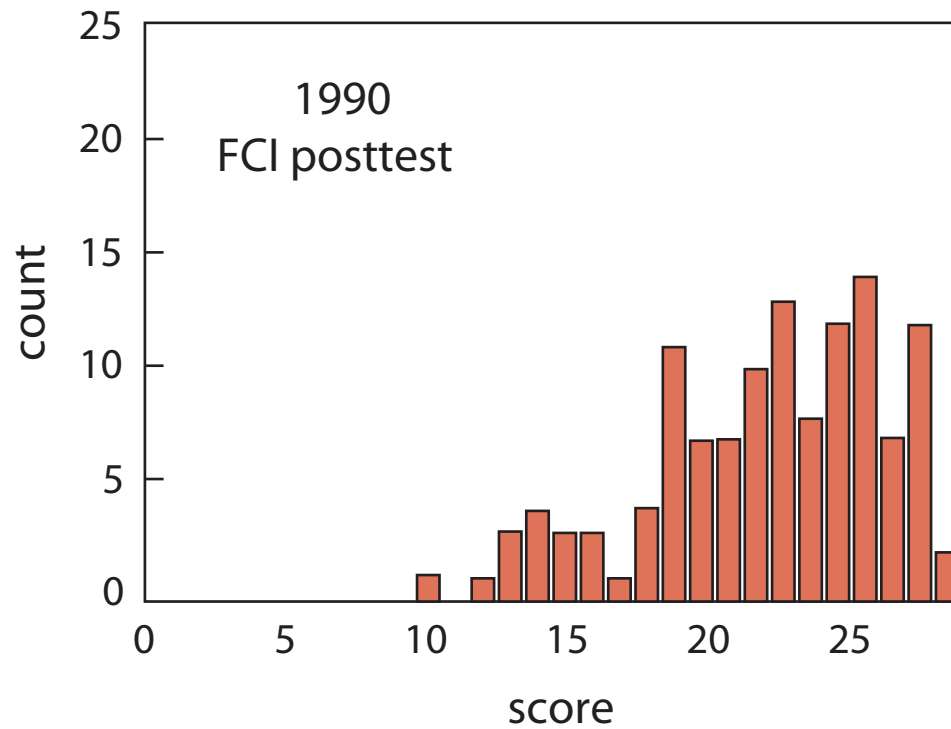

# Education

education is not just information transfer

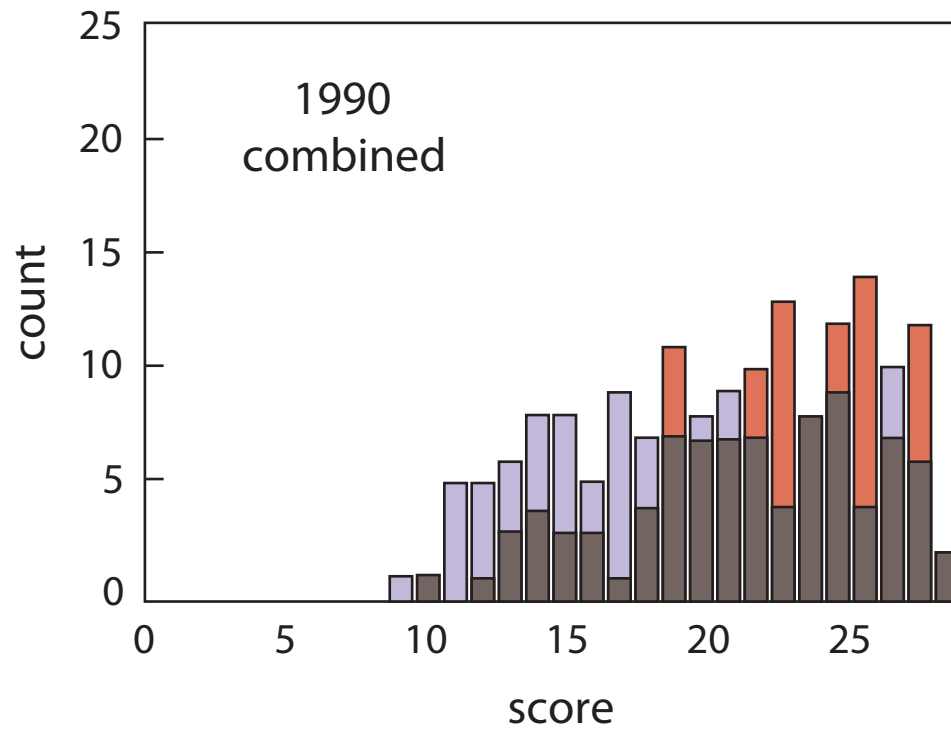

# Education

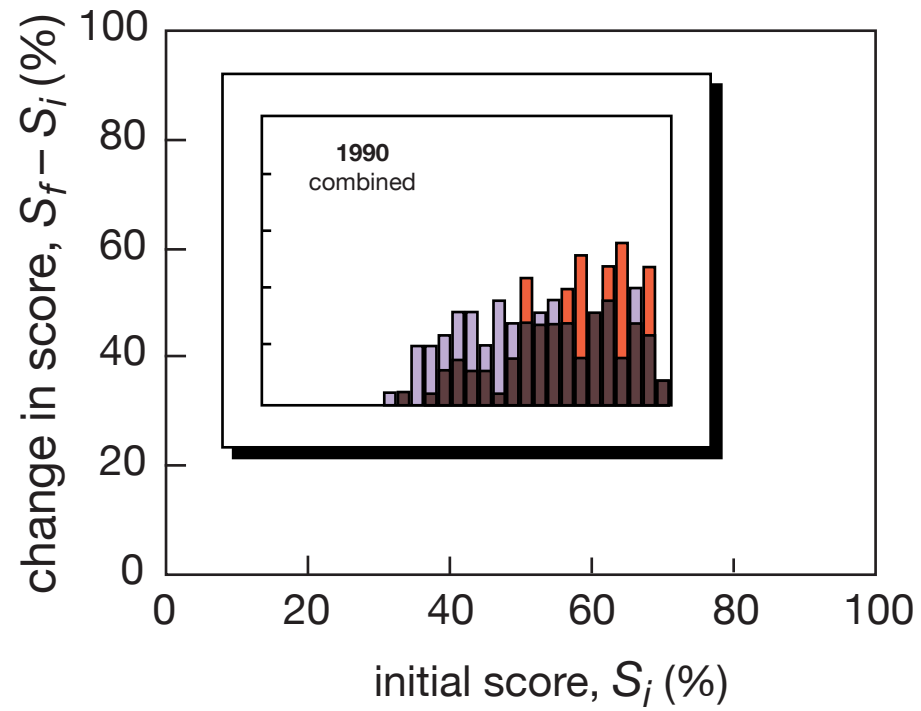

# Education

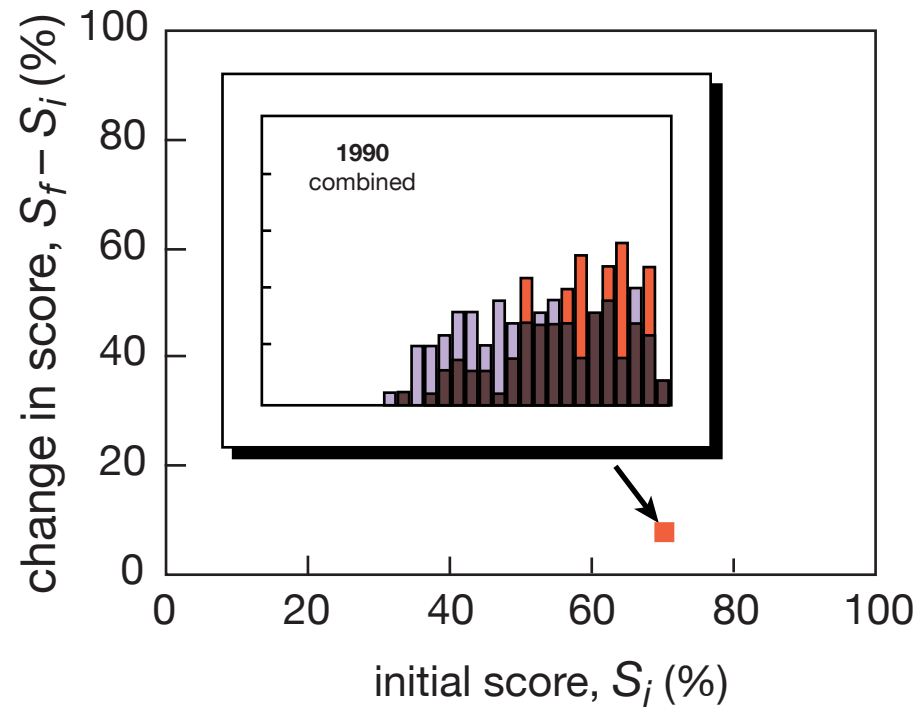

# Education

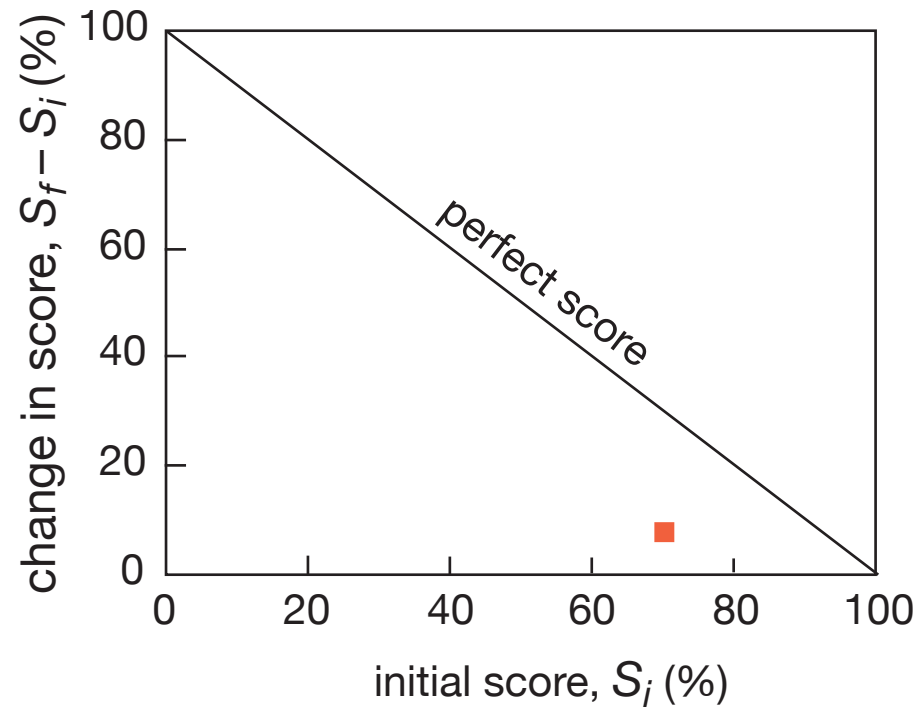

# Education

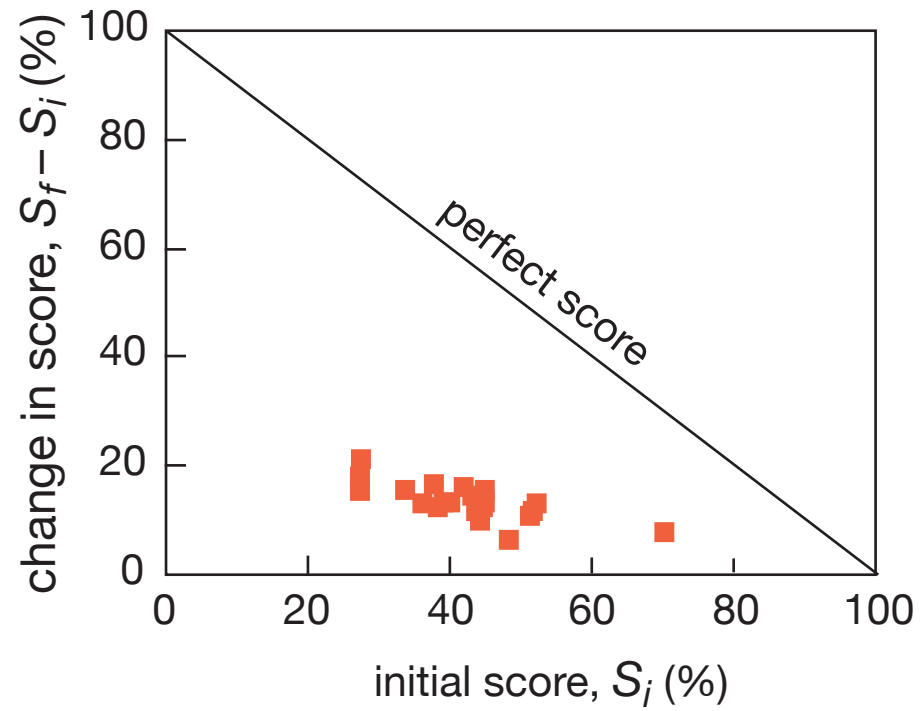

# Education

only one quarter of maximum gain realized

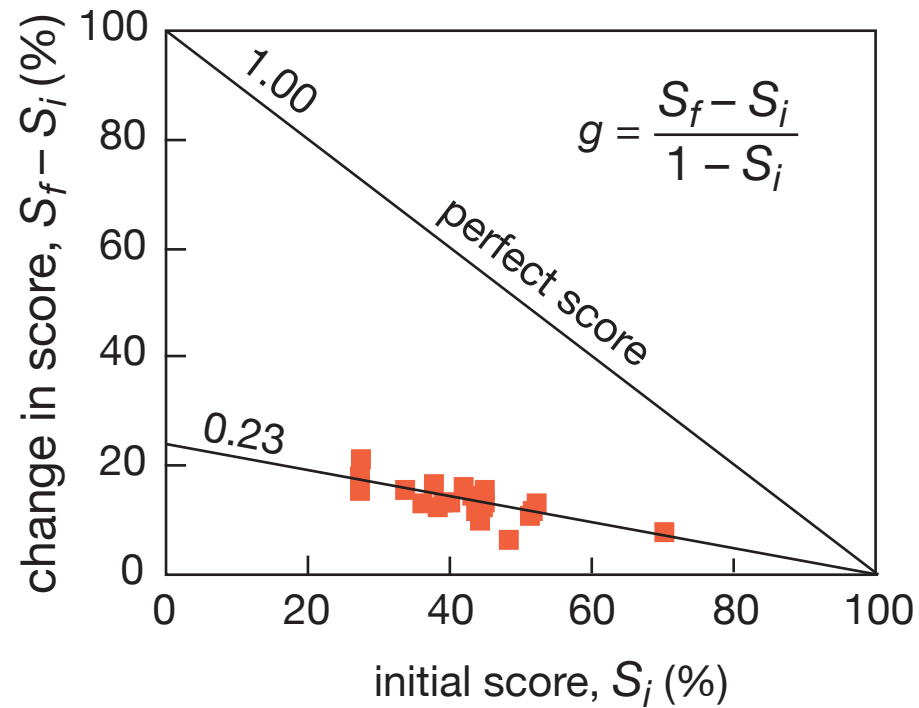



# Education

**not transfer but assimilation of information is key**

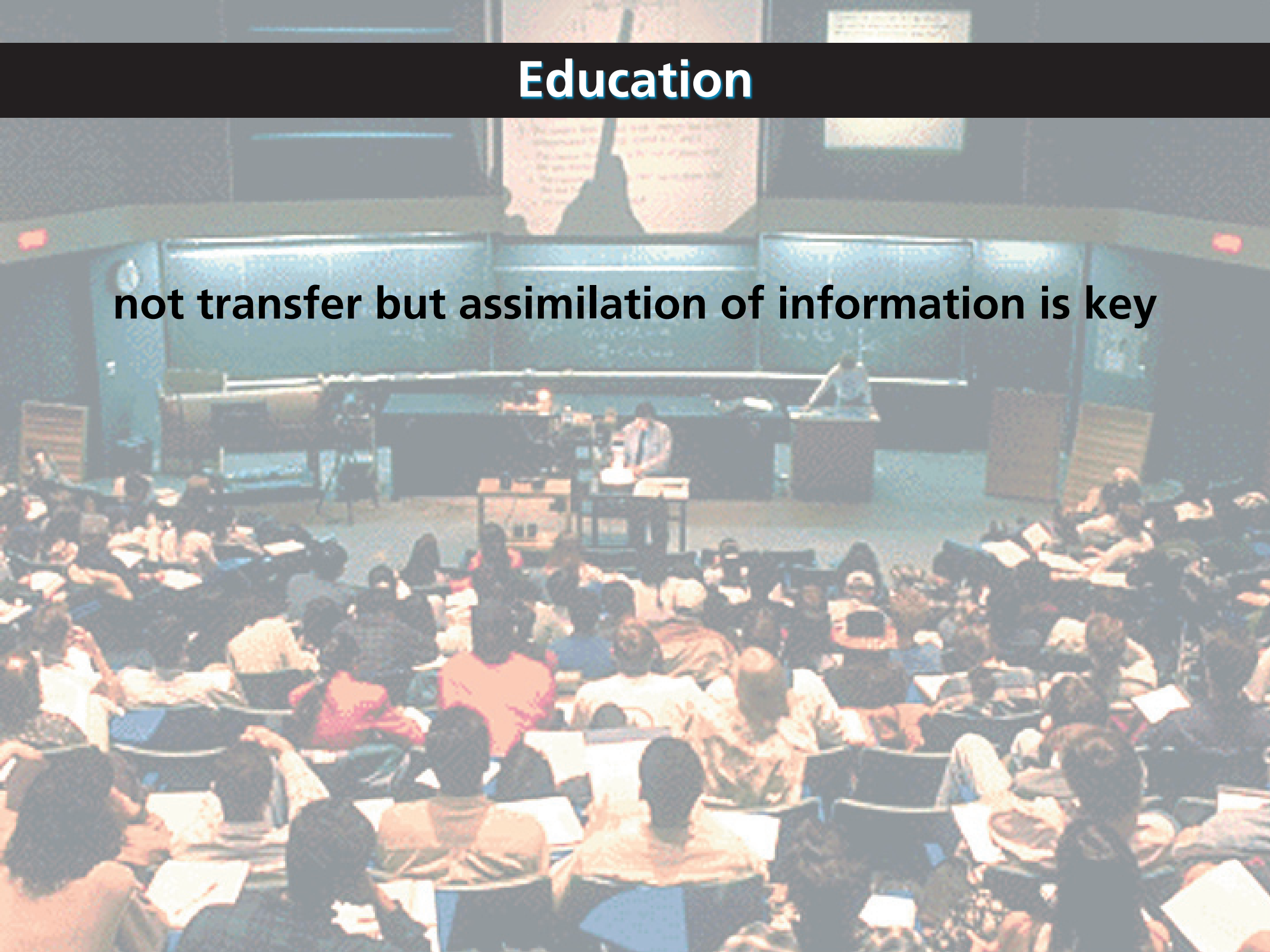

# Education

conventional problems misleading

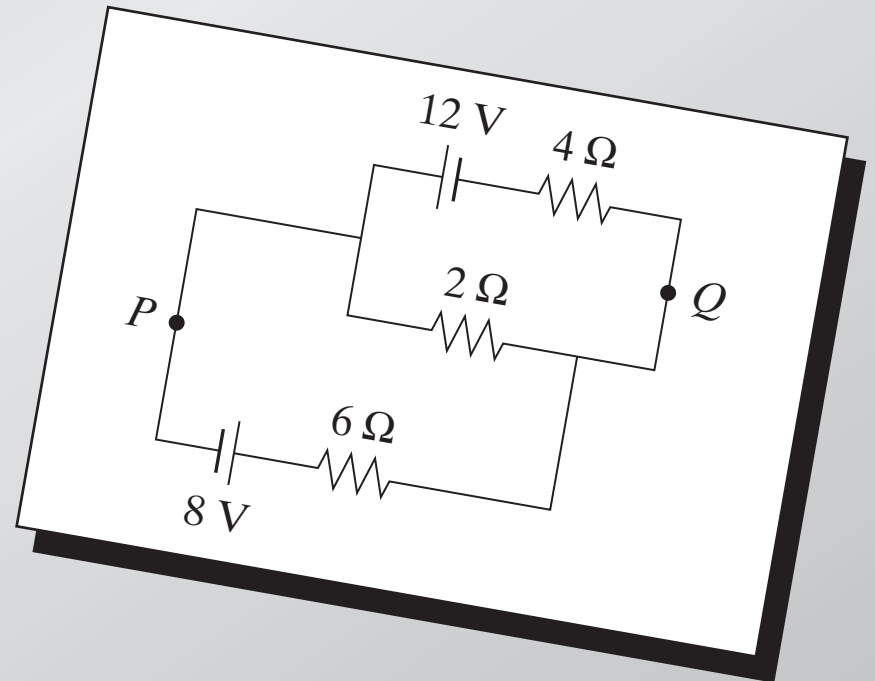

# Education

conventional problems misleading

Calculate:

(a) current in 2- $\Omega$  resistor

(b) potential difference

between  $P$  and  $Q$

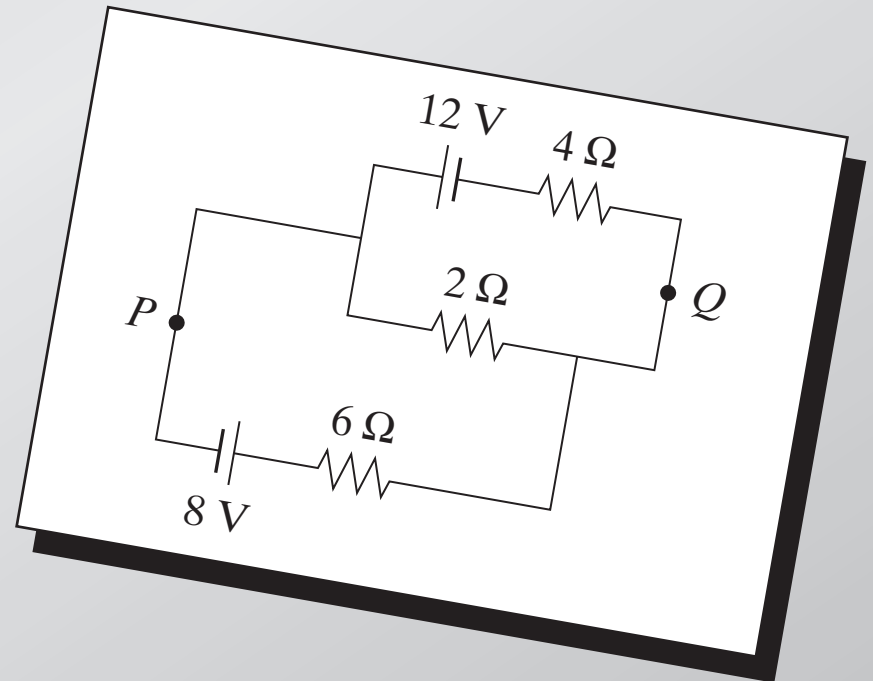

# Education

are the basic principles understood?

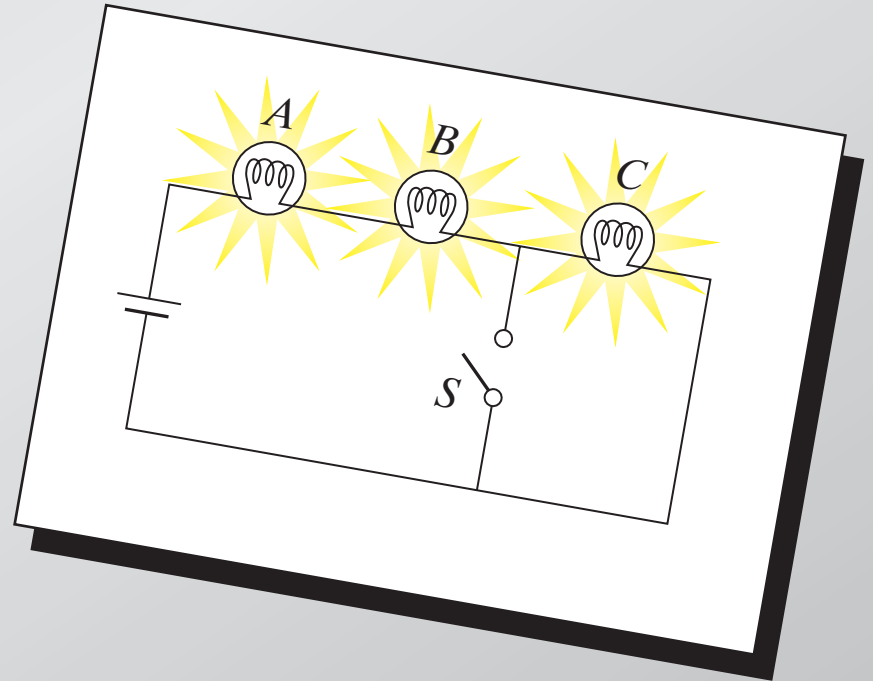

# Education

are the basic principles understood?

When  $S$  is closed, what happens to:

- (a) intensities of  $A$  and  $B$ ?
- (b) intensity of  $C$ ?
- (c) current through battery?
- (d) potential difference across  
 $A$ ,  $B$ , and  $C$ ?
- (e) the total power dissipated?

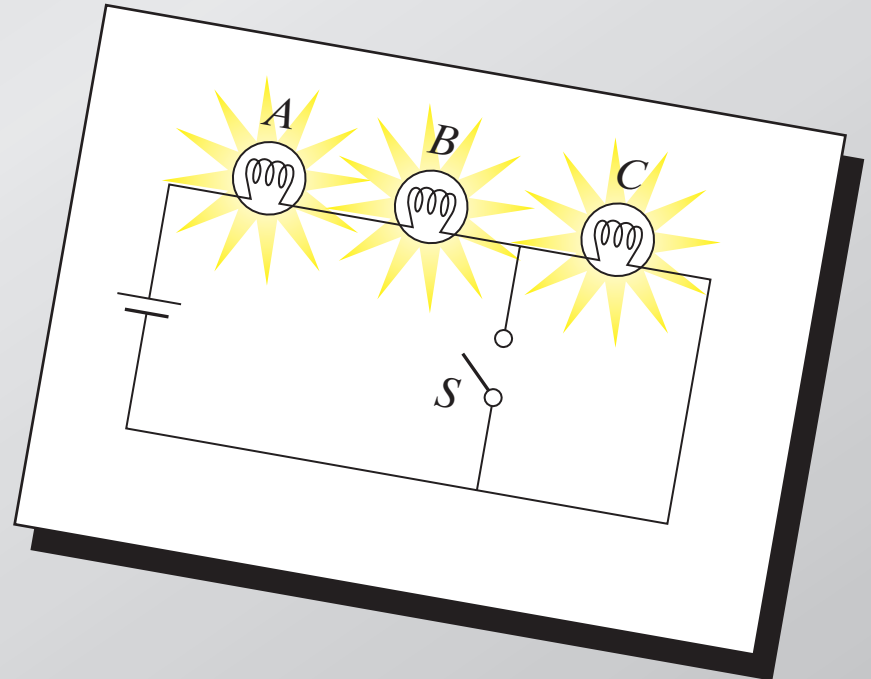

# Education

## conventional

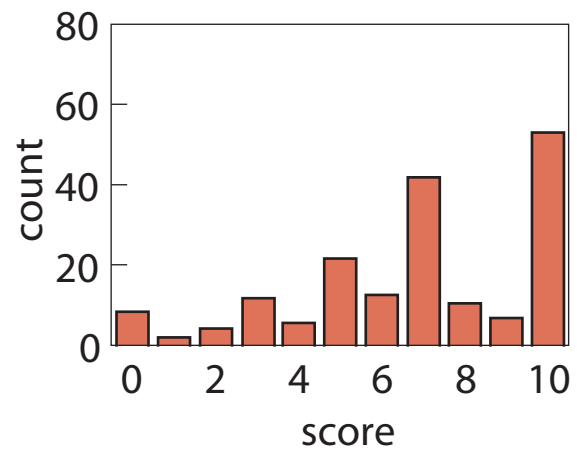

## conceptual

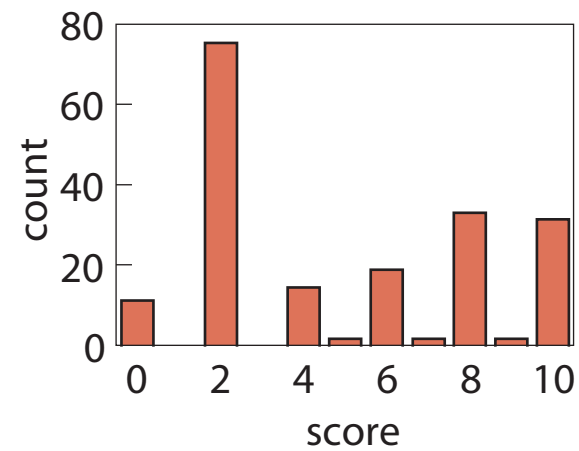

# Education

## conventional

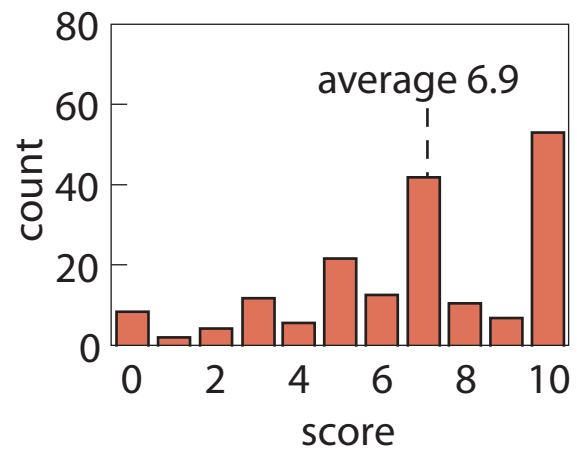

## conceptual

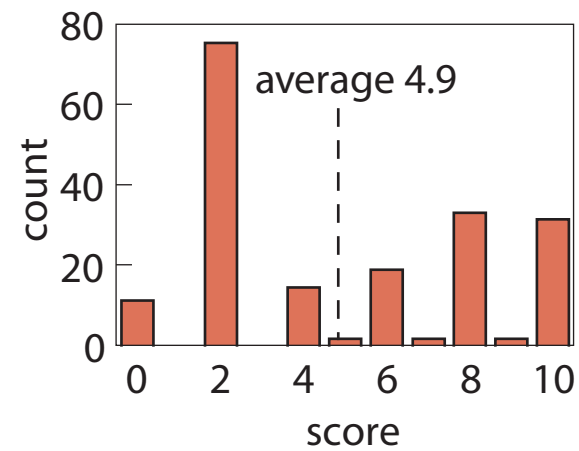

# Education

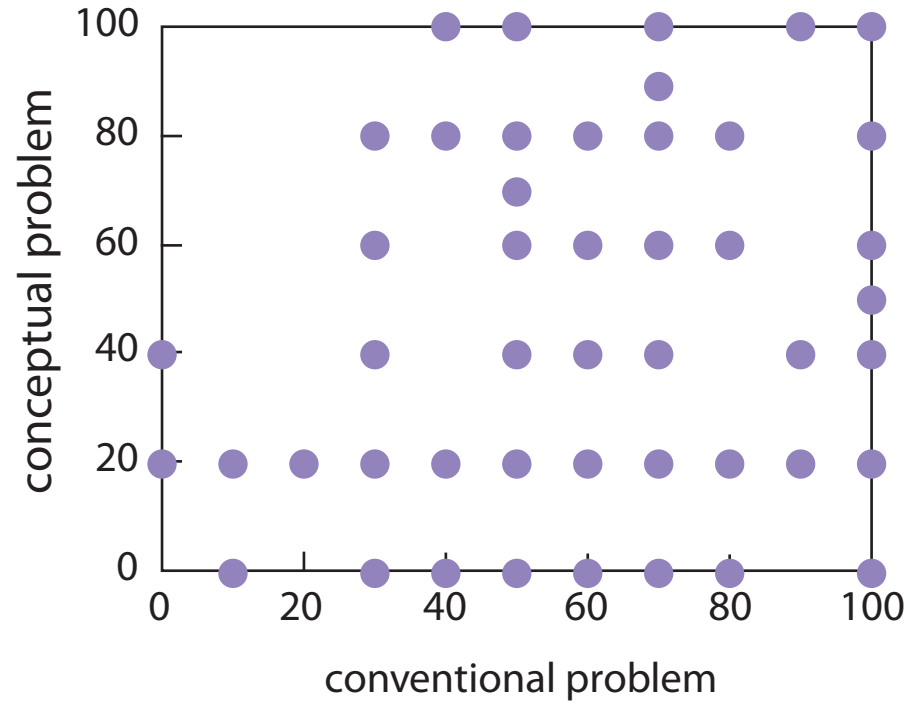



# Education

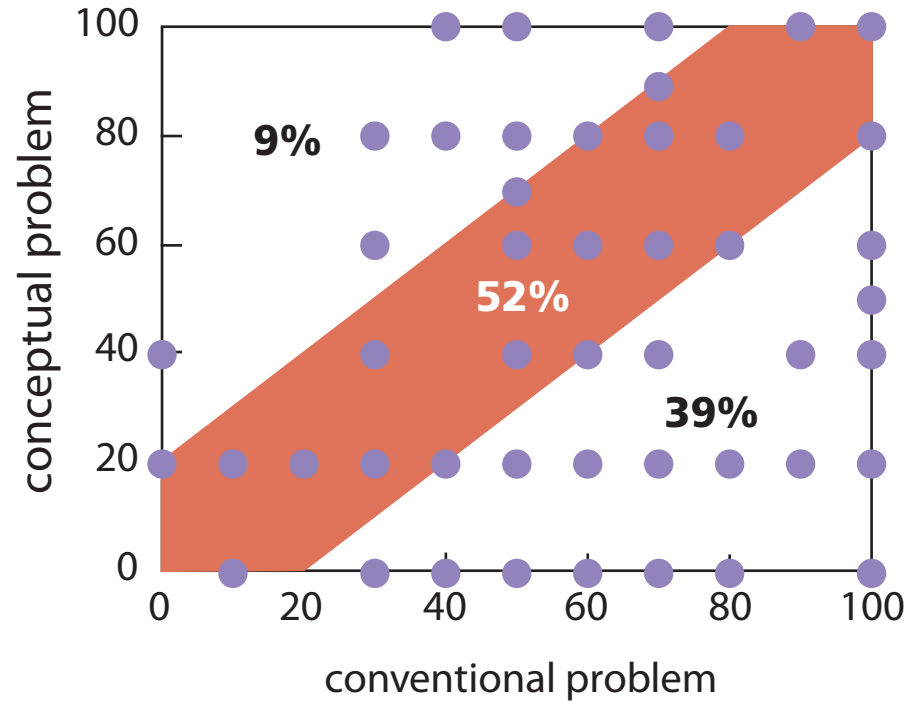

A large lecture hall with students seated at desks, facing a stage with a lecturer and a large screen displaying text. The text on the screen is partially legible and appears to be a list of items or a document. The room is dimly lit, with the stage area being the primary light source. The students are mostly seen from behind, looking towards the front of the room. The lecturer is standing at a podium on the stage, facing the audience. The overall atmosphere is that of a formal academic setting.

So what should we do?

# Peer Instruction

**Give students more responsibility for gathering information...**

# Peer Instruction

**Give students more responsibility for gathering information...  
so we can better help them assimilate it.**

# Peer Instruction

## Main features:

- pre-class reading
- in-class: depth, not 'coverage'
- ConcepTests

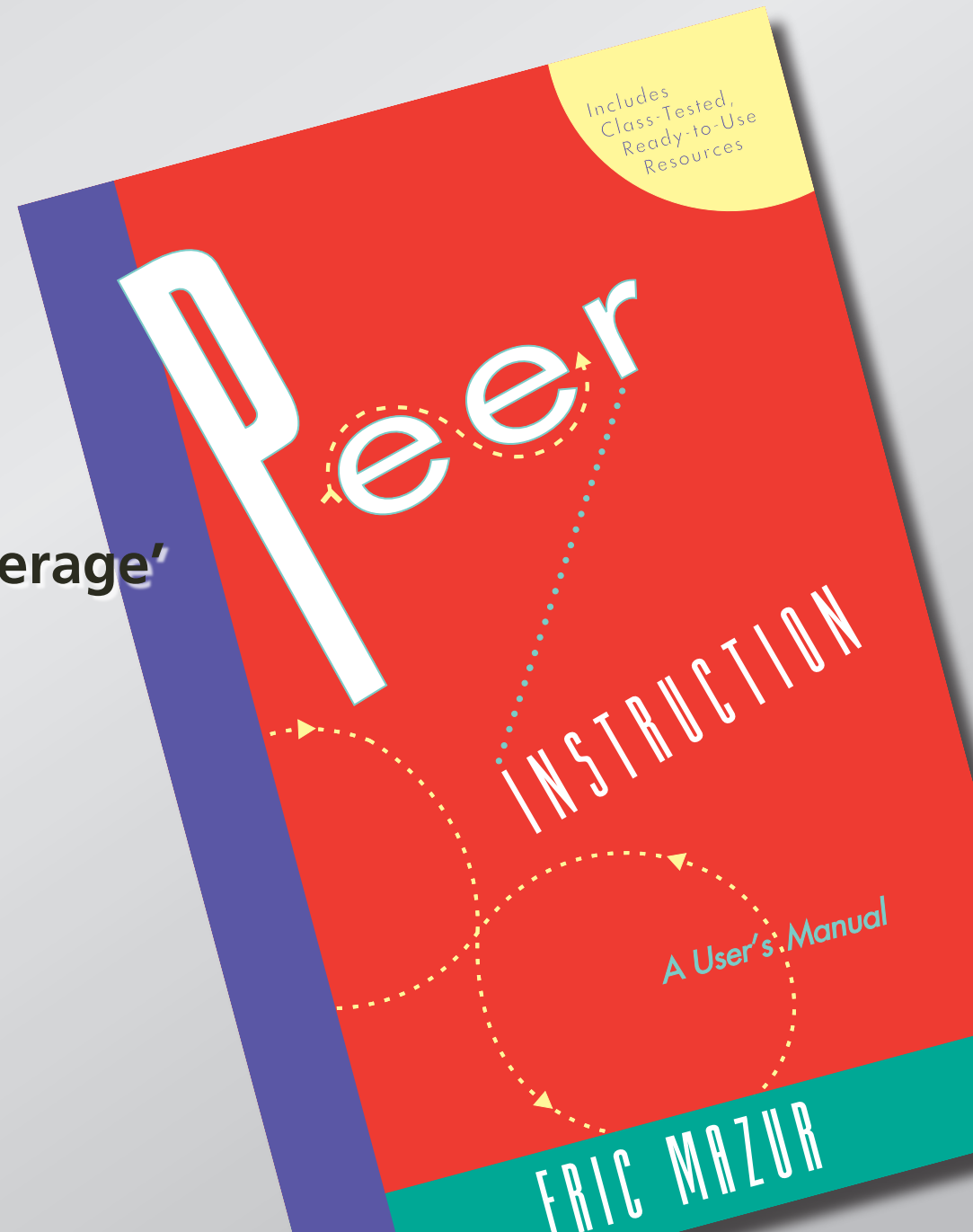

# Peer Instruction

**ConcepTest:**

- 1. Question**
- 2. Thinking**
- 3. Individual answer**
- 4. Peer discussion**
- 5. Revised/Group answer**
- 6. Explanation**



# Results

is it any good?



# Results

## first year of implementing PI

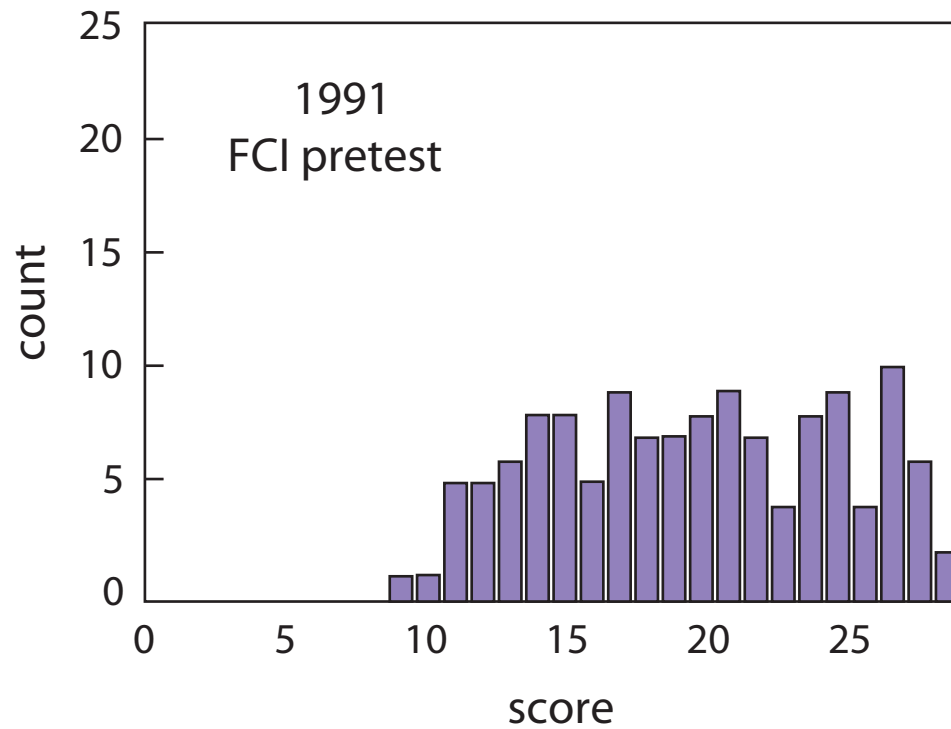

# Results

## first year of implementing PI

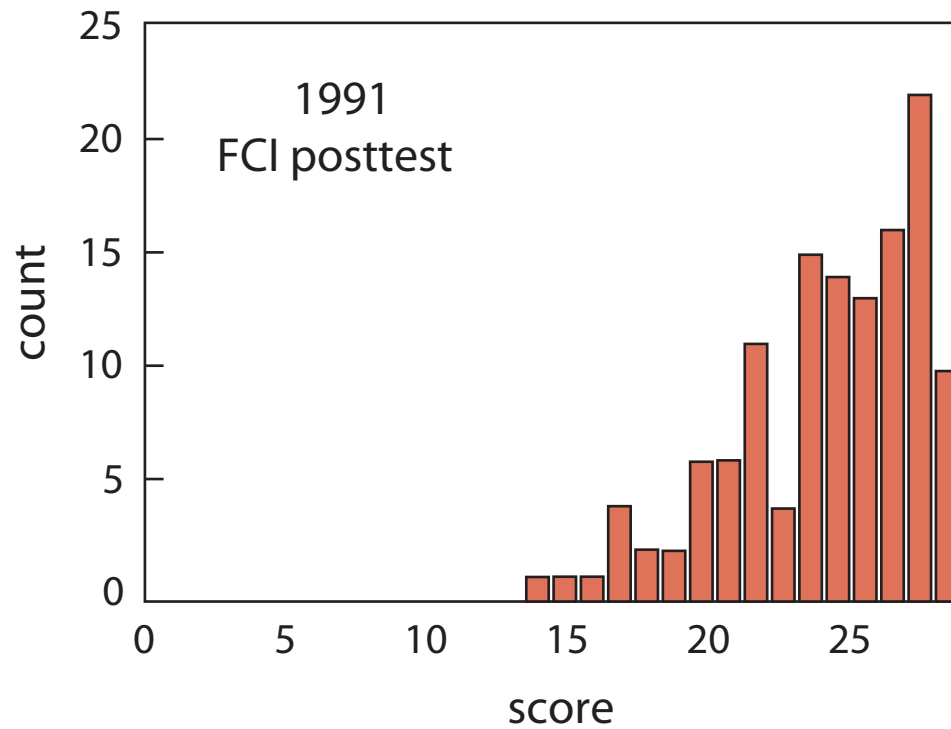

# Results

## first year of implementing PI

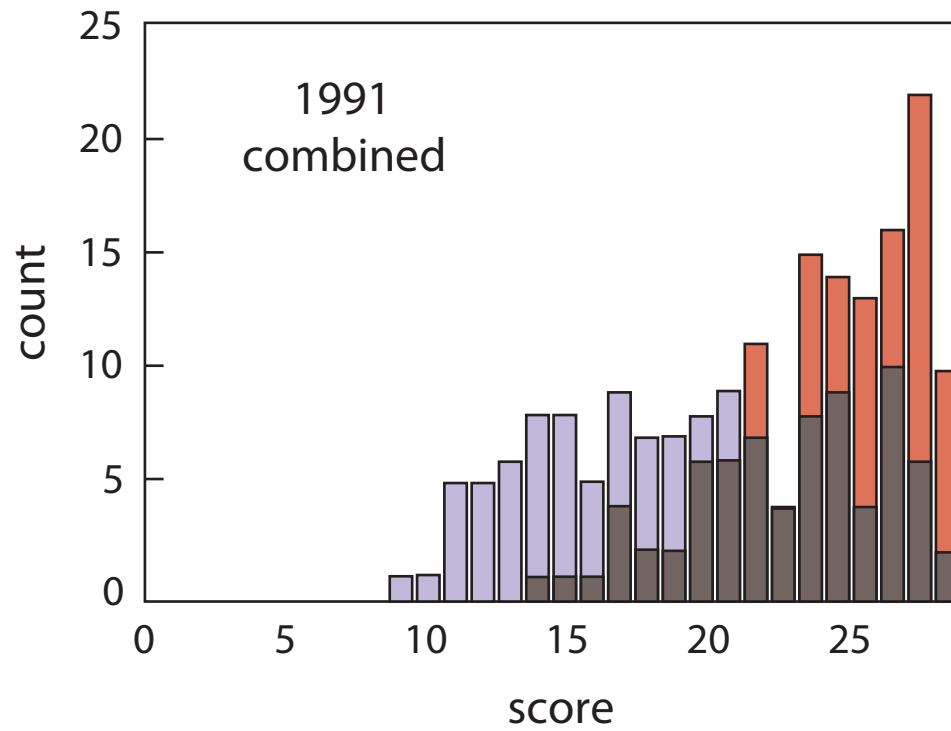

# Results

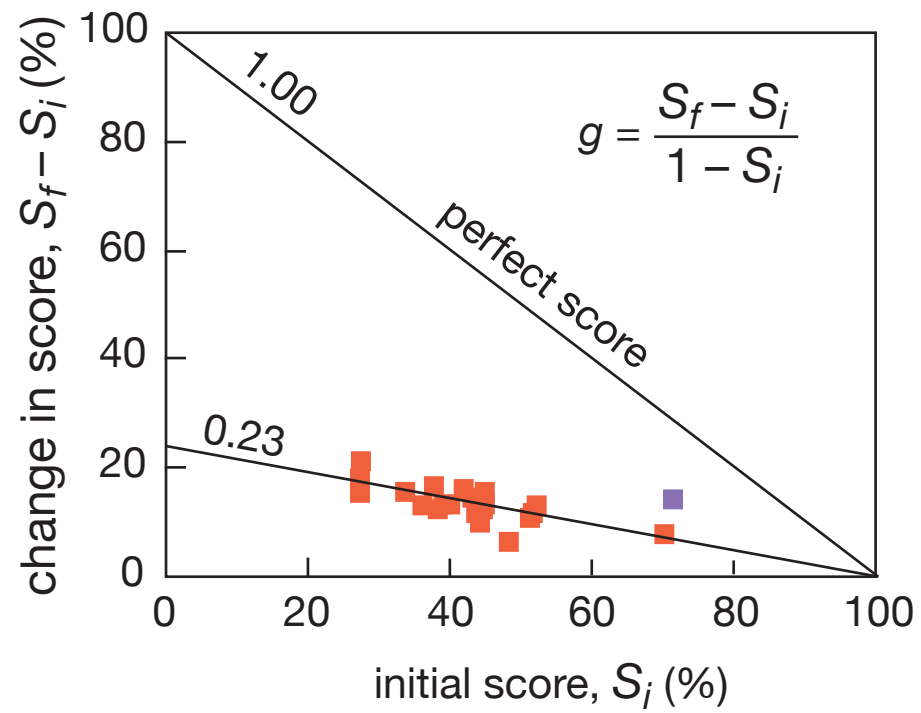

# Results

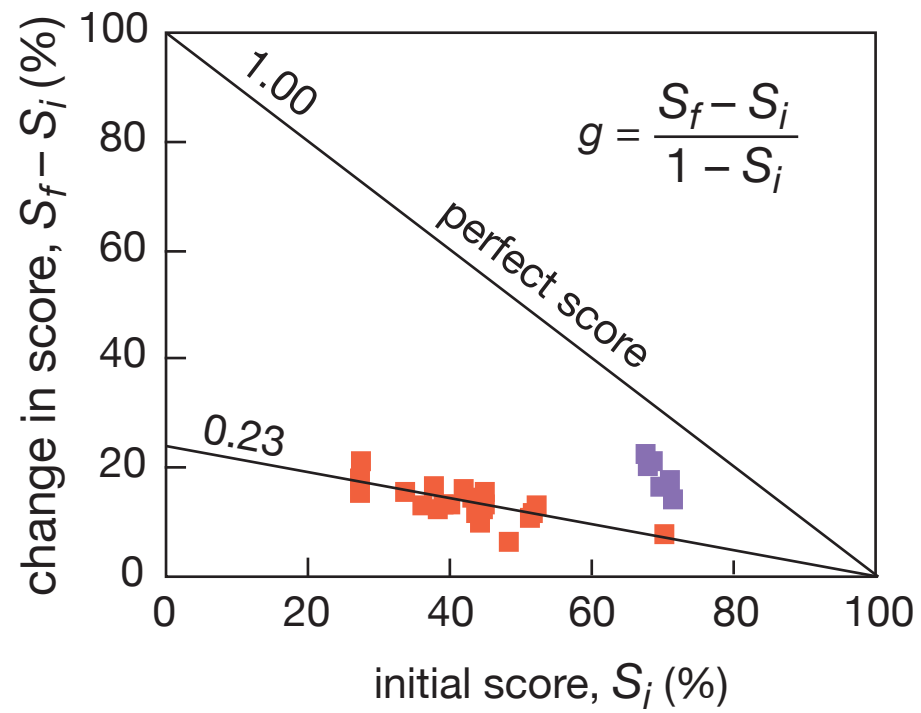

# Results

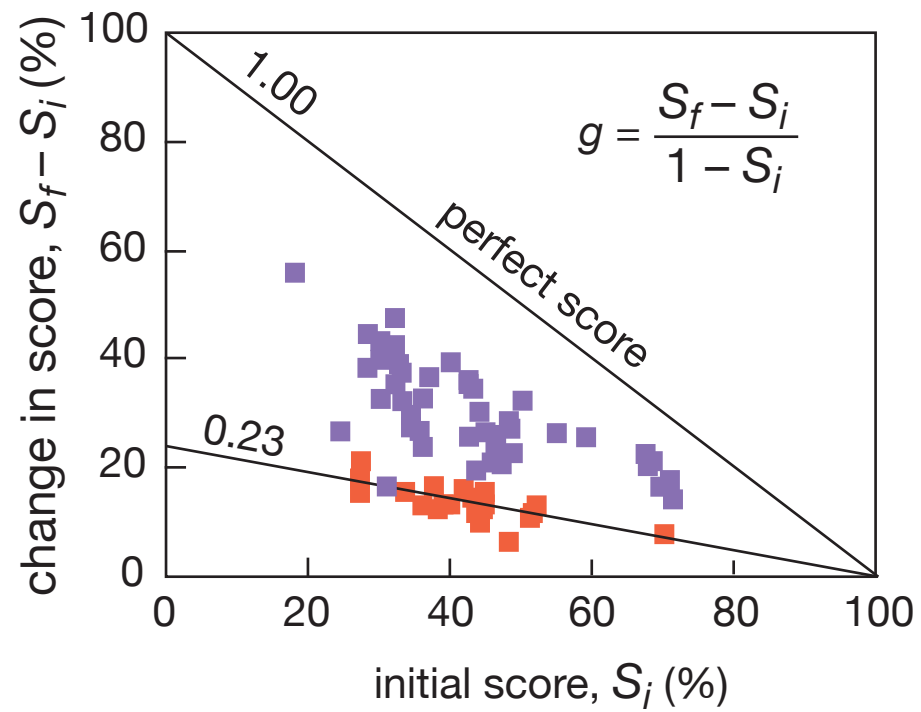

# Results

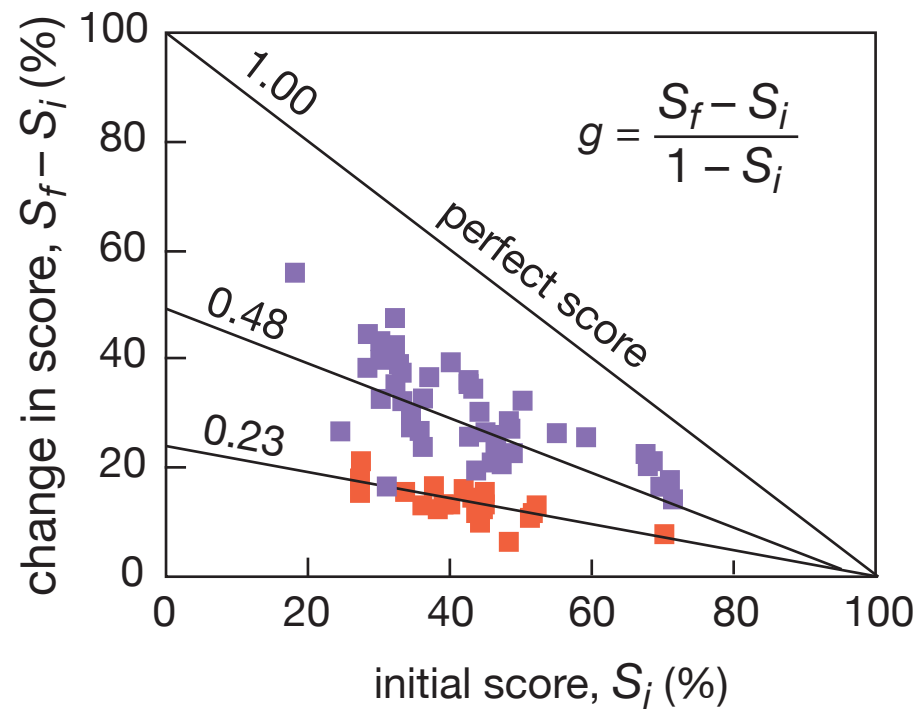

# Results

**what about problem solving?**



# Results

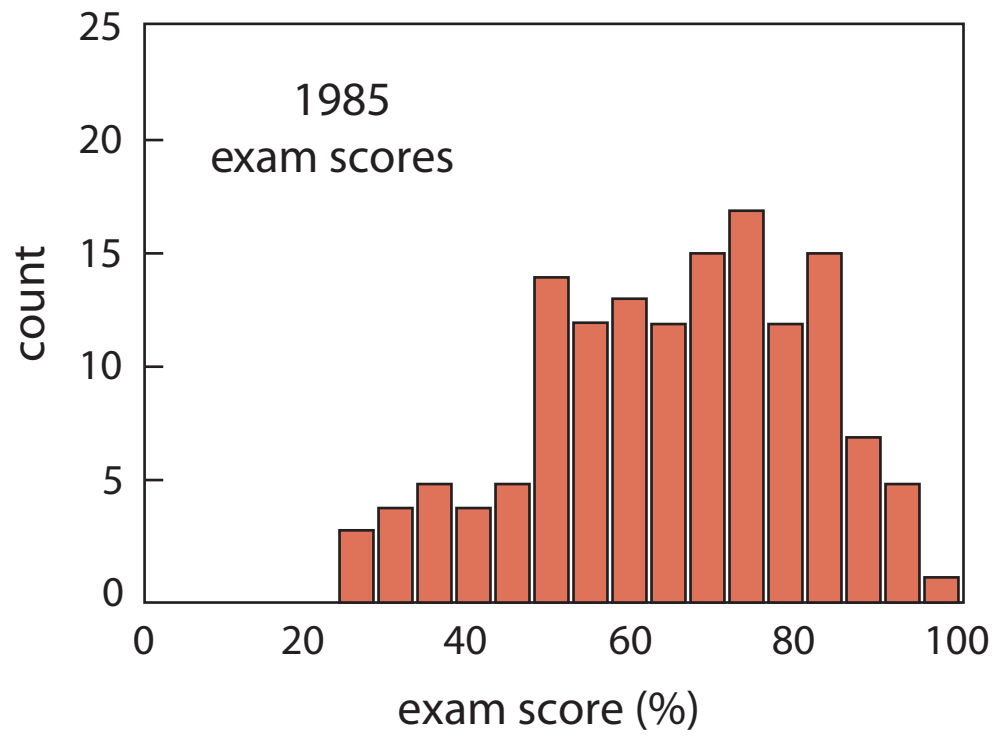

# Results

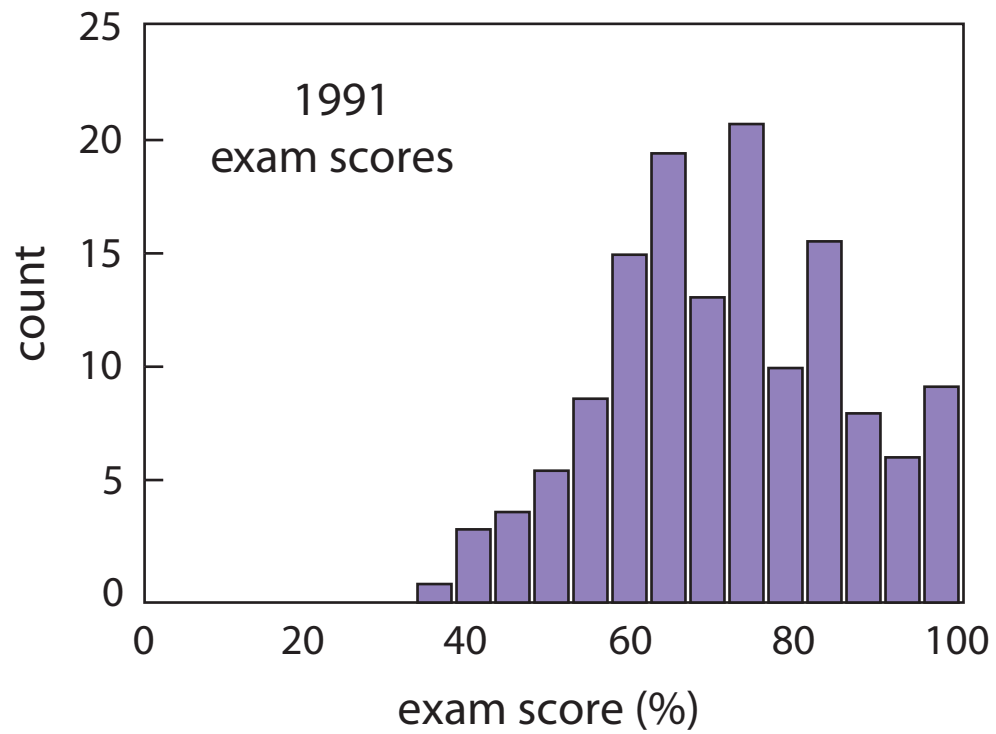

# Results

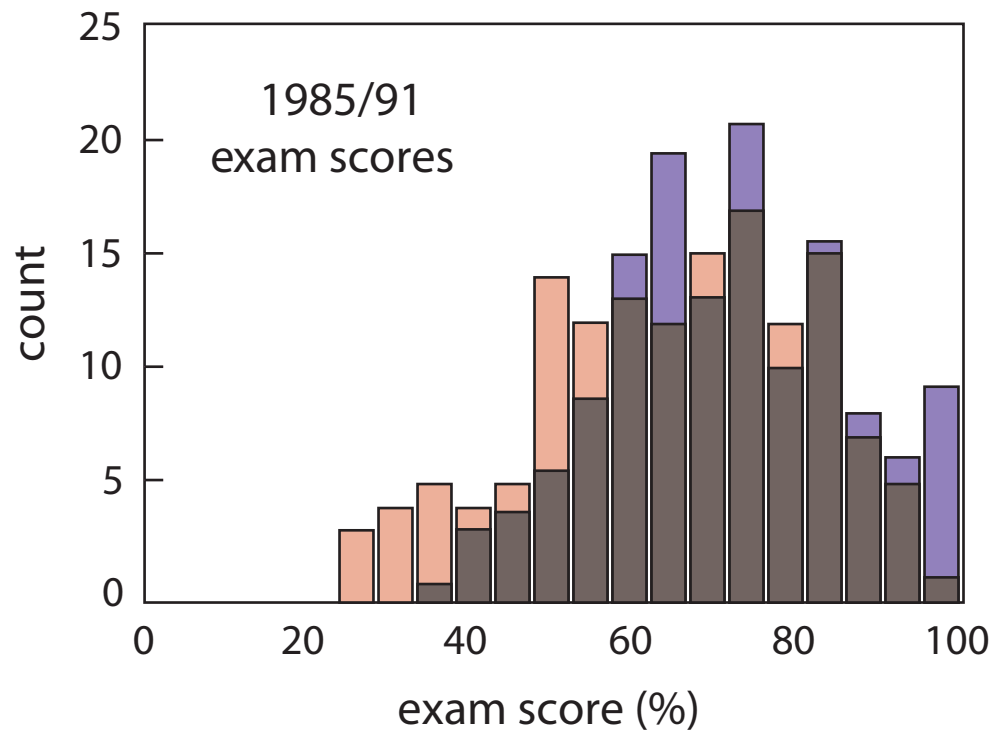

# Summary

**So better understanding leads to better  
problem solving!**

# Summary

**So better understanding leads to better problem solving!**

**(but “good” problem solving doesn’t always indicate understanding!)**



**Funding:**

**National Science Foundation**

**for a copy of this presentation:**

**<http://mazur-www.harvard.edu>**

Google™

Google Search

I'm Feeling Lucky



Google™

mazur

Google Search

I'm Feeling Lucky

# Google™

Google Search

I'm Feeling Lucky

# Google™

mazur

Google Search

I'm Feeling Lucky

**Funding:**

**National Science Foundation**

**for a copy of this presentation:**

**<http://mazur-www.harvard.edu>**