

# Introduction to Peer Instruction

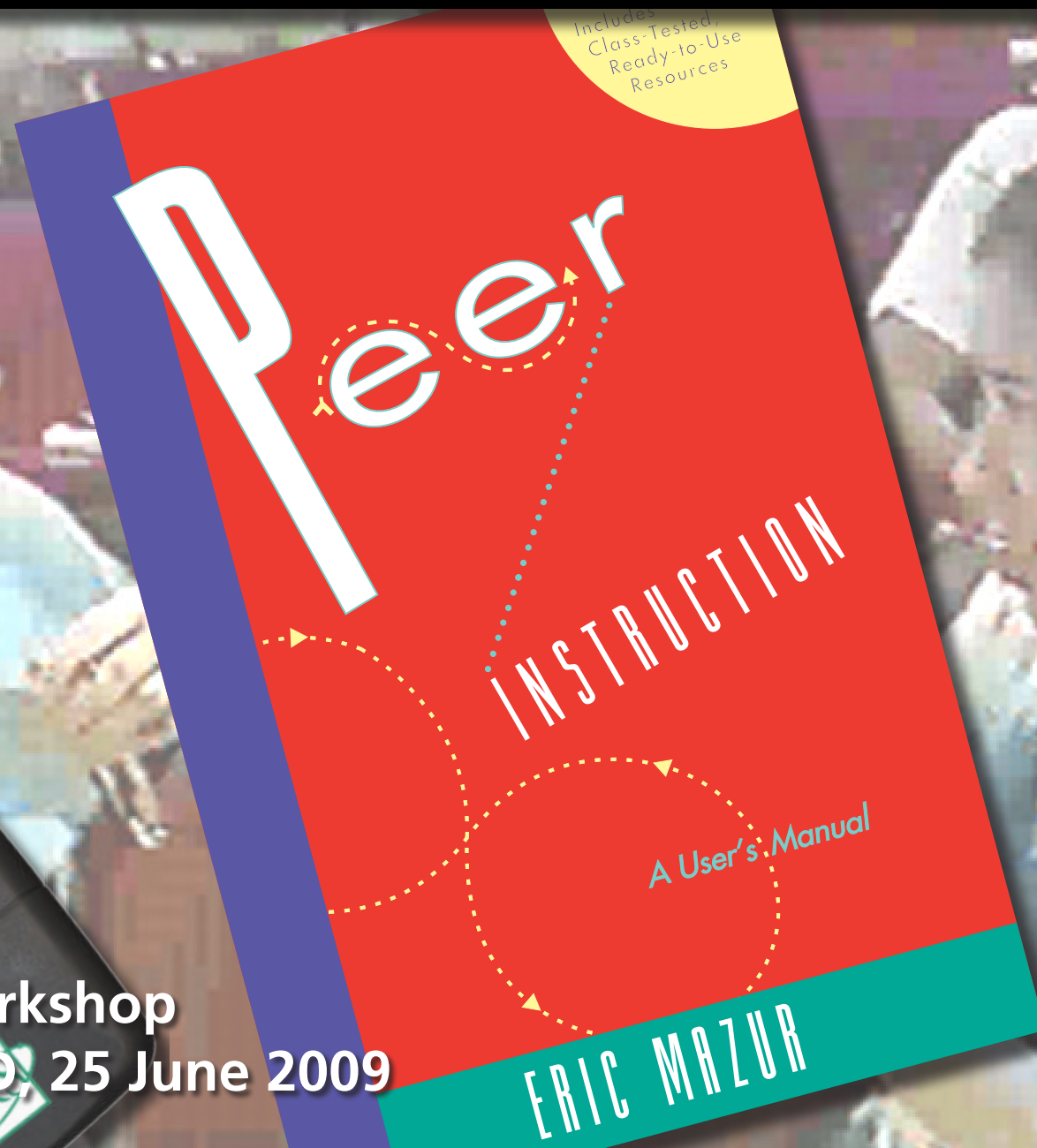

New Faculty Workshop  
College Park, MD, 25 June 2009

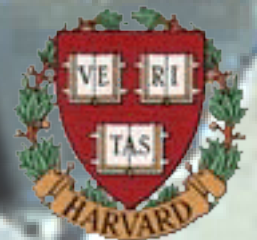

# My message

**shift focus from "teaching" to helping students learn**



# Outline

- Education



# Outline

- Education
- Peer Instruction



# Outline

- Education
- Peer Instruction
- Results



# Education



# Education

lectures focus on delivery of information

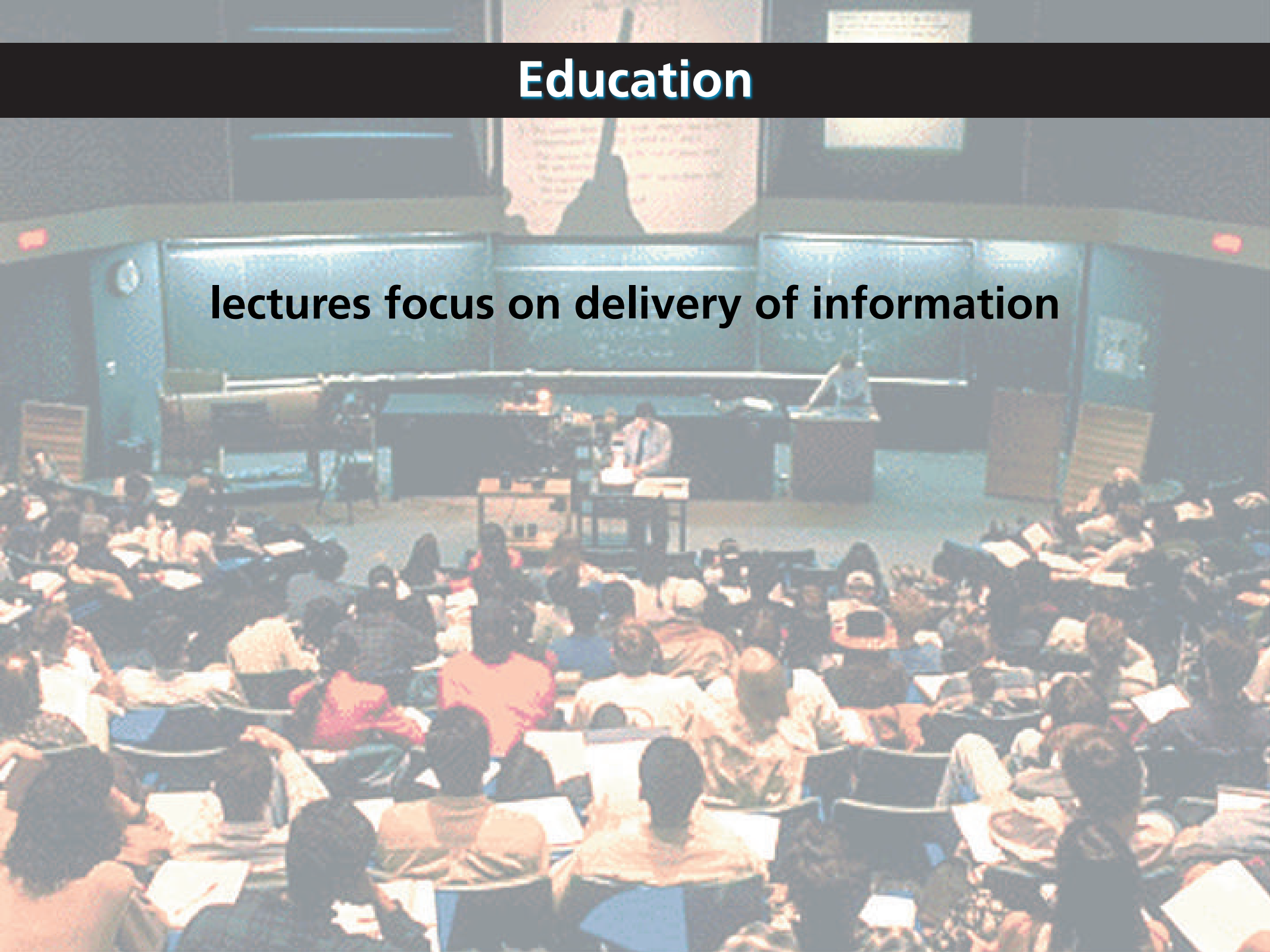

# Education

education is not just information transfer

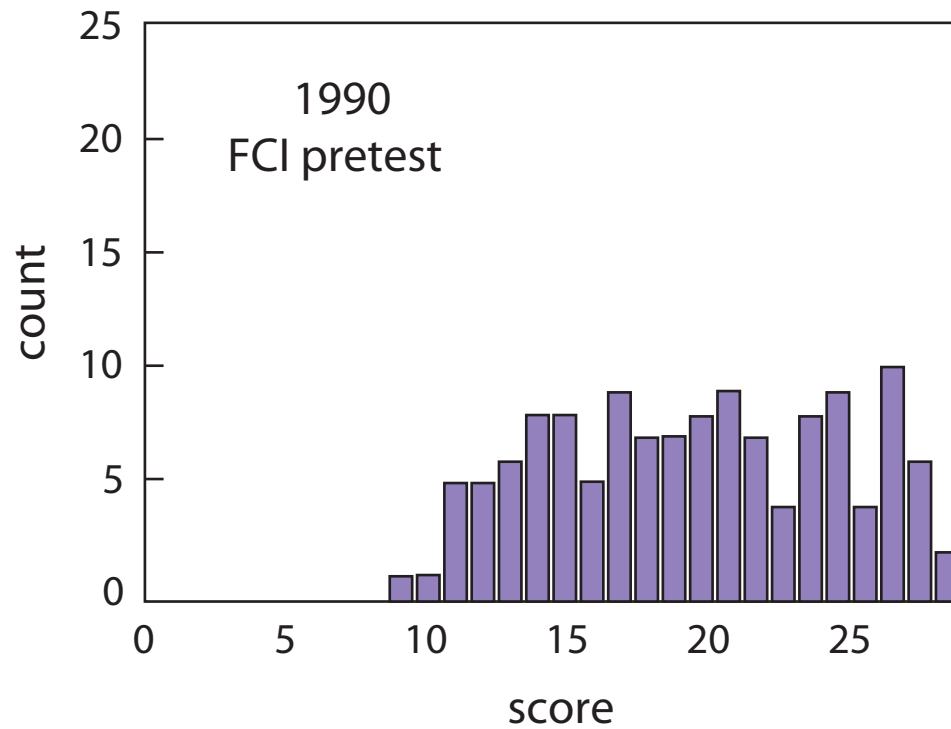



# Education

education is not just information transfer

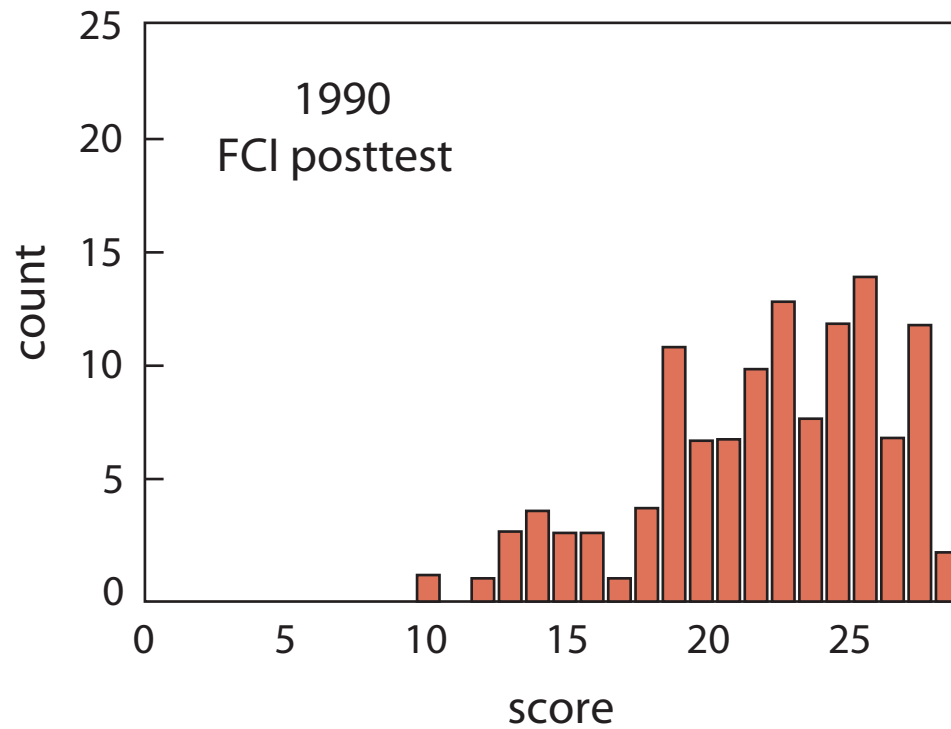

# Education

education is not just information transfer

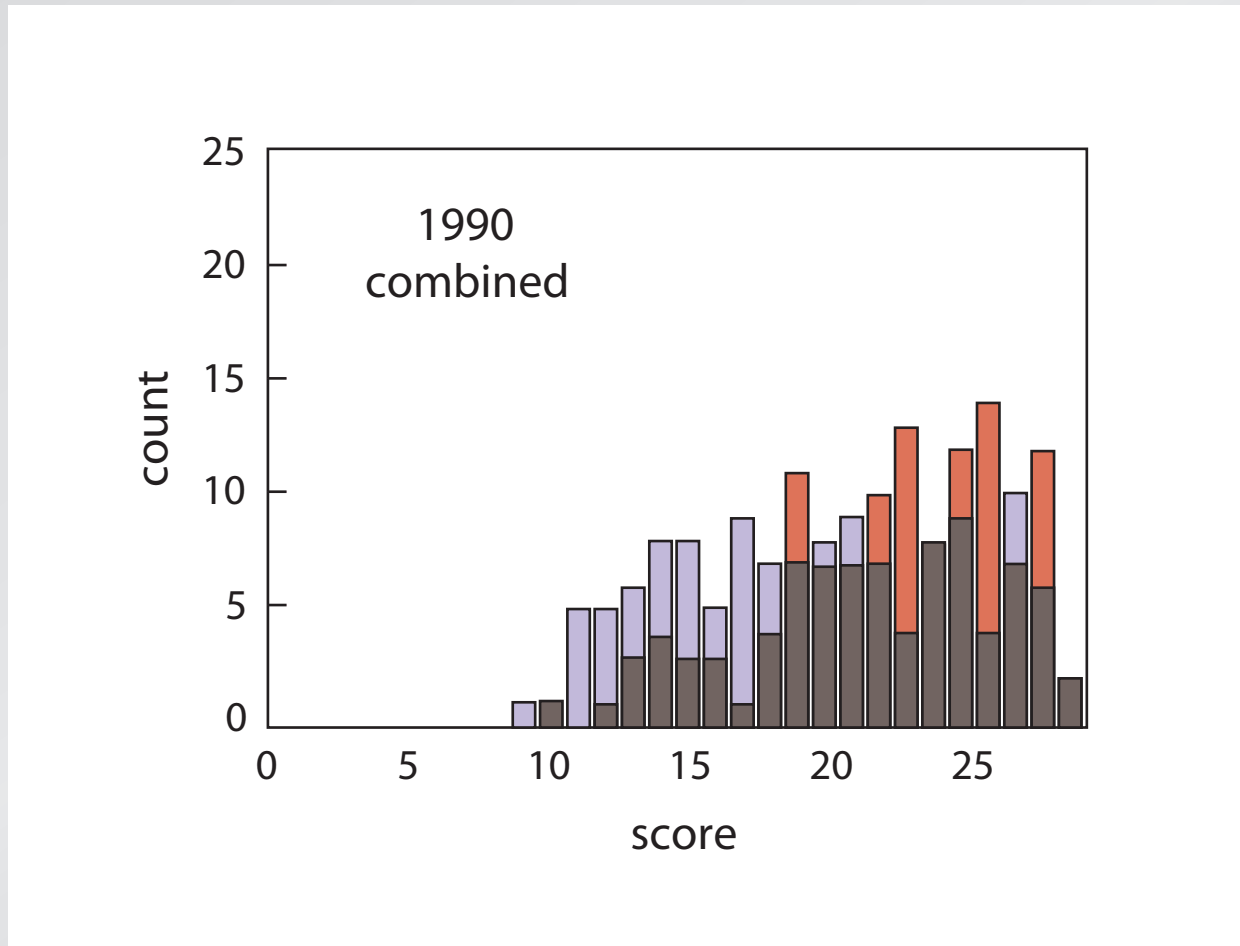

# Education

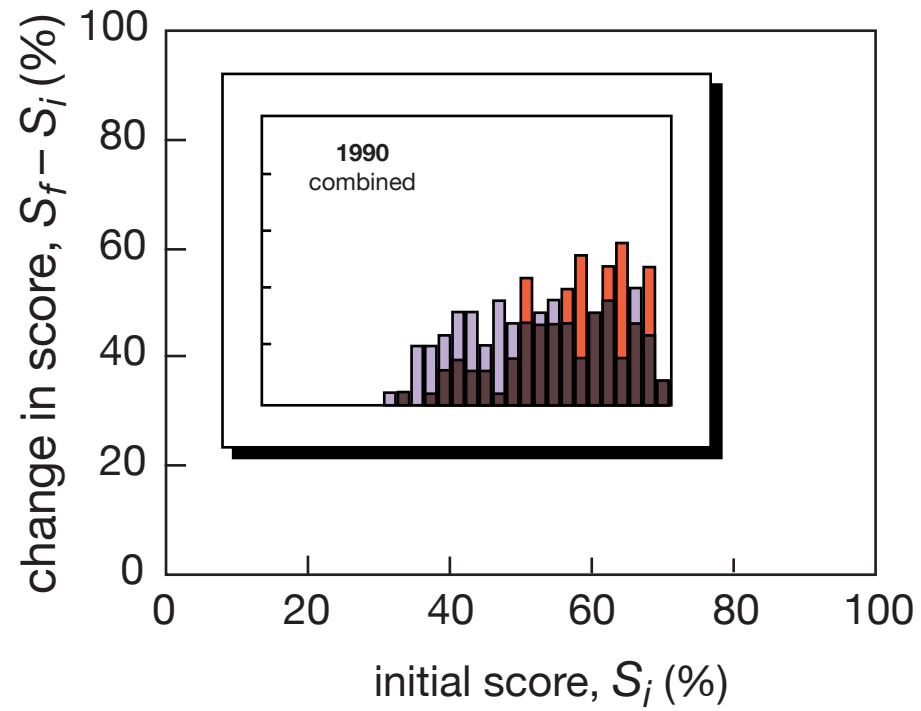

# Education

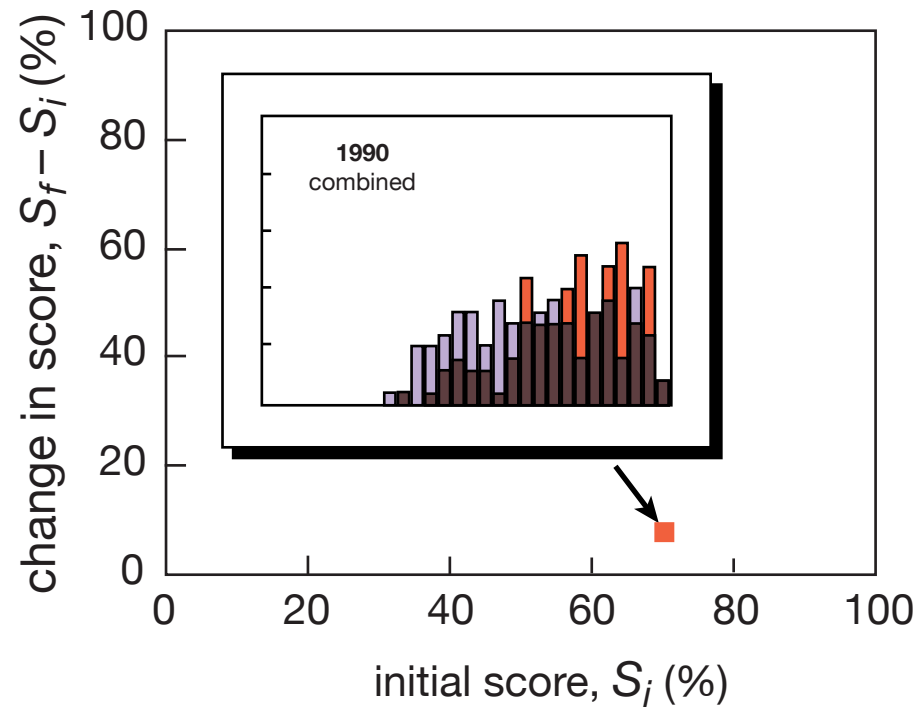

# Education

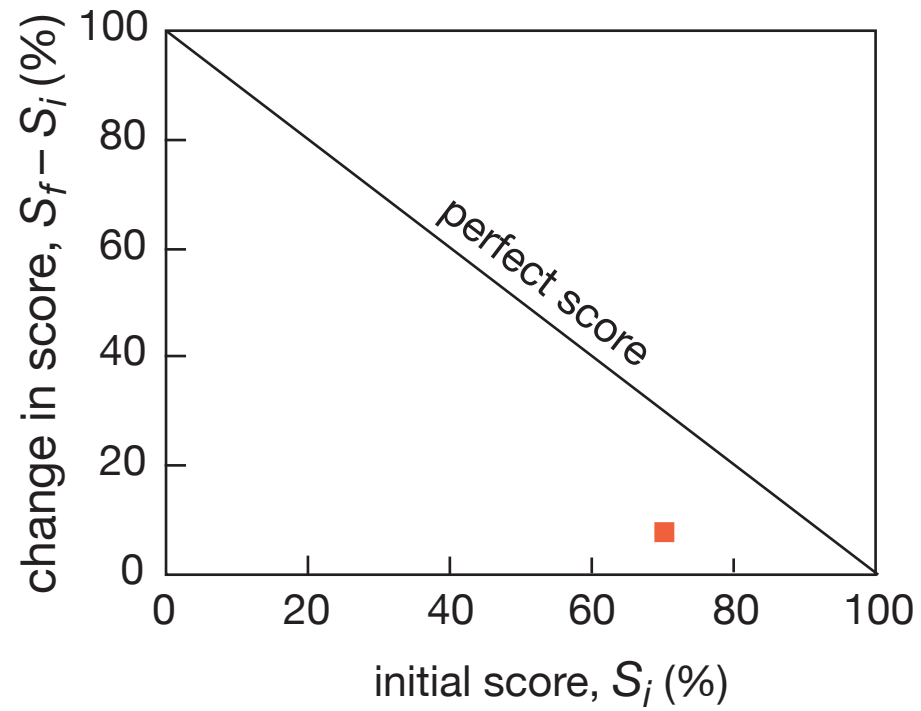

# Education

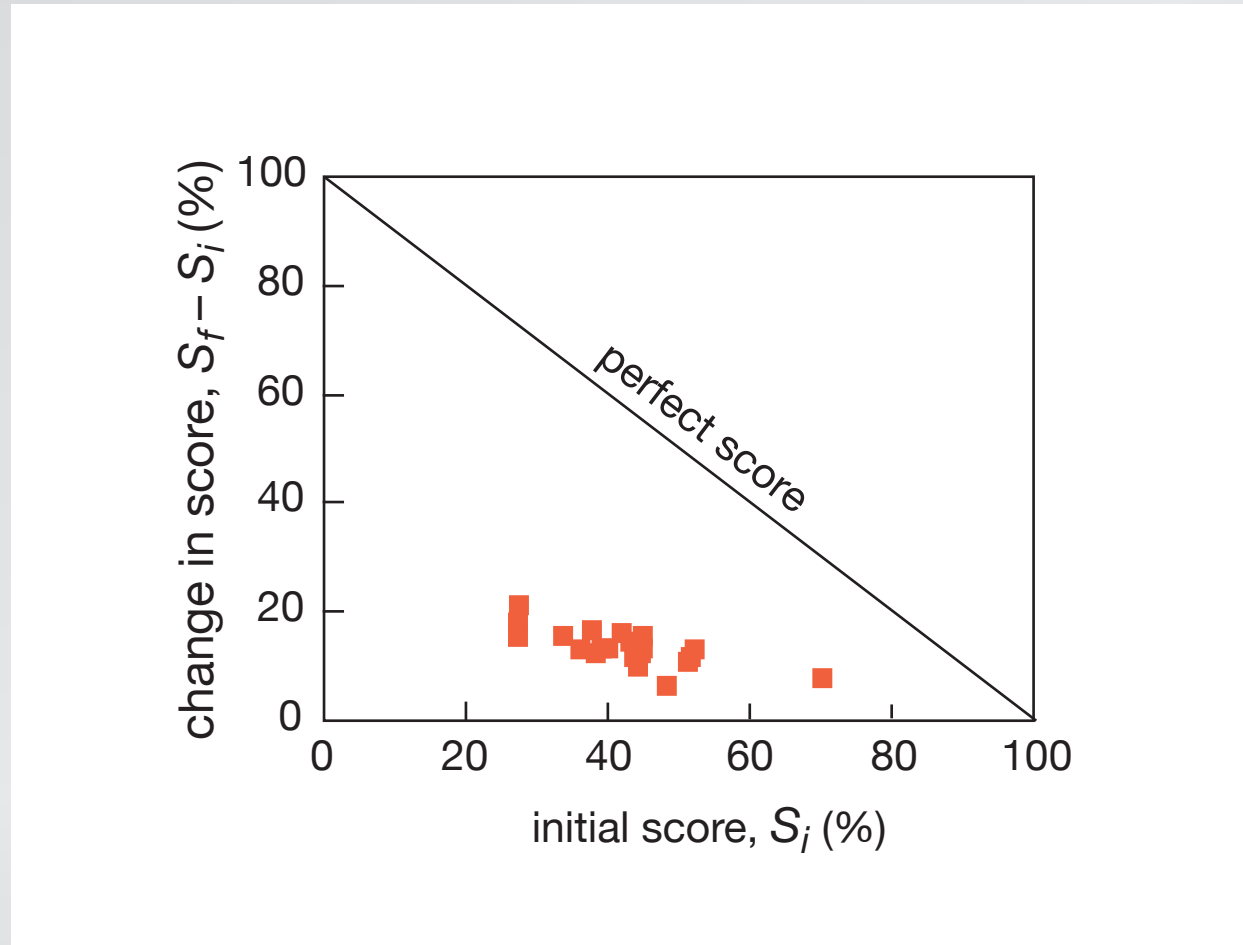

# Education

only one quarter of maximum gain realized

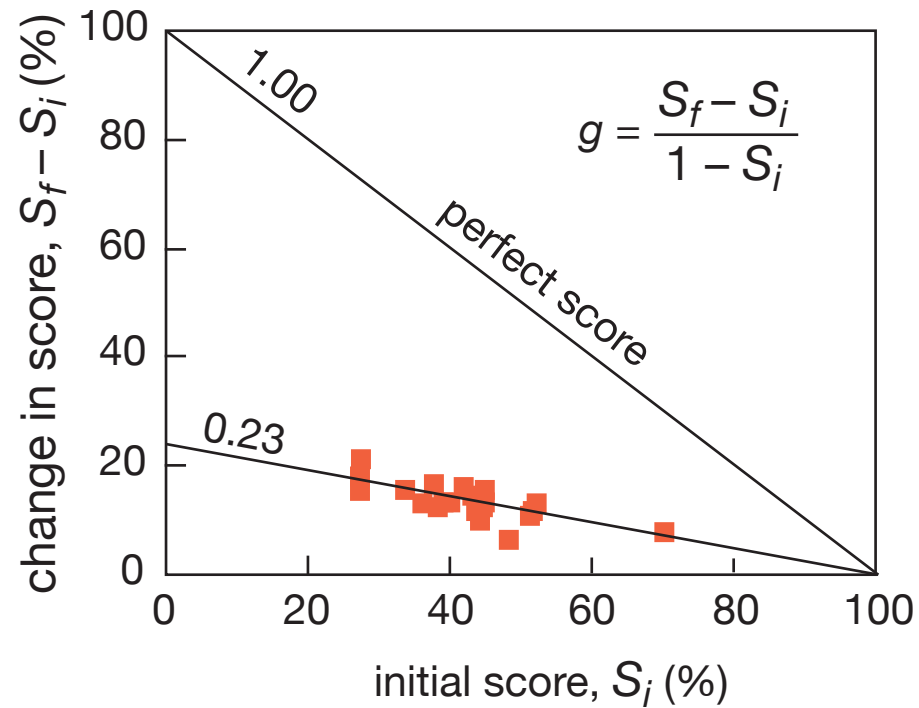

# Education

**not transfer but assimilation of information is key**

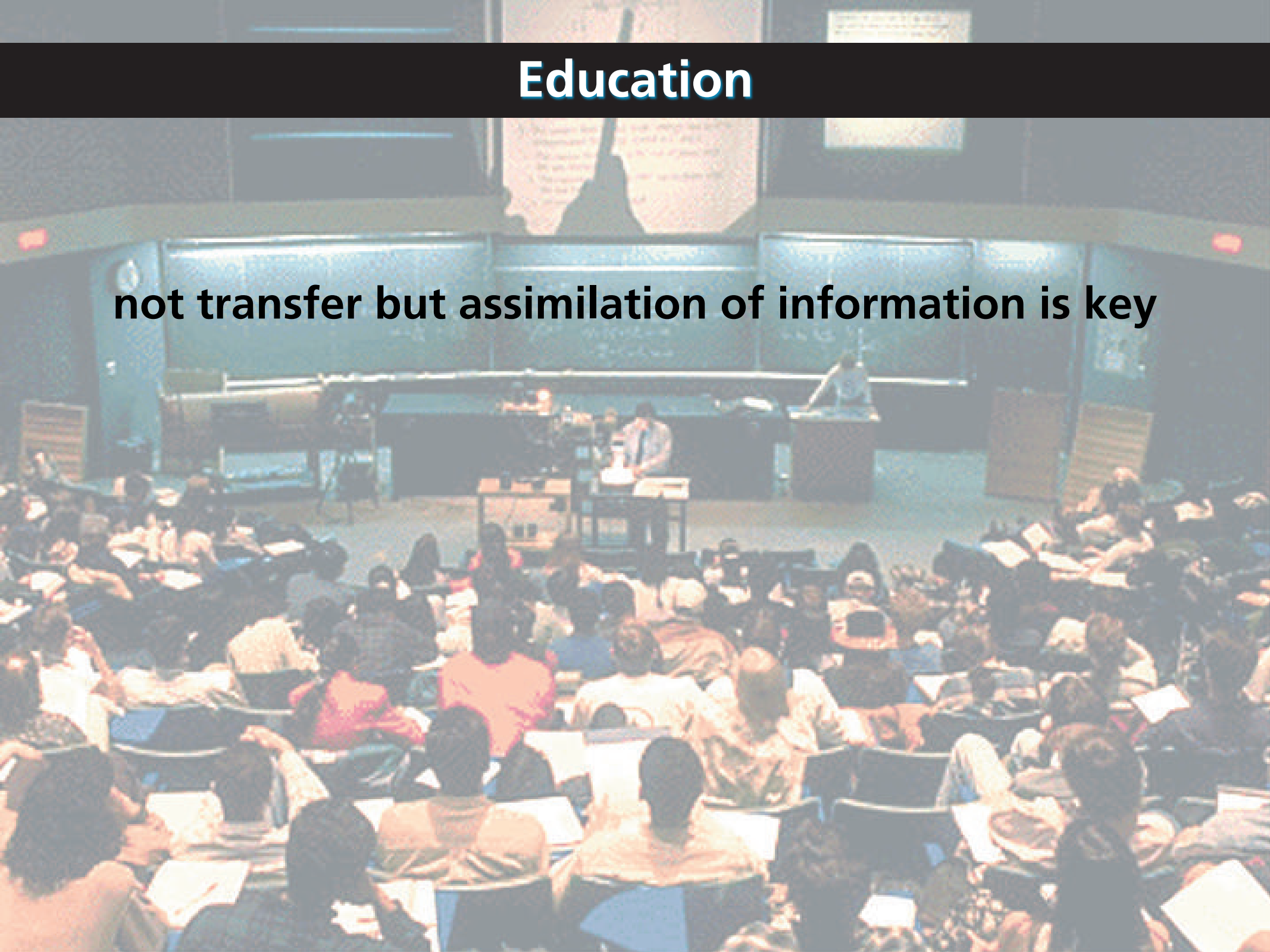



# Education

conventional problems misleading

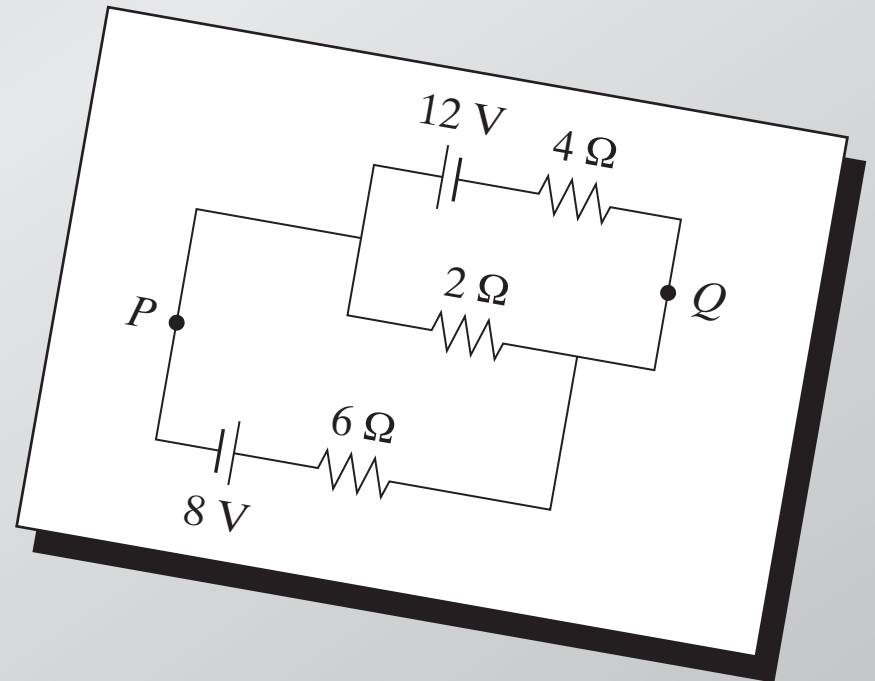

# Education

conventional problems misleading

Calculate:

(a) current in  $2\text{-}\Omega$  resistor

(b) potential difference

between  $P$  and  $Q$

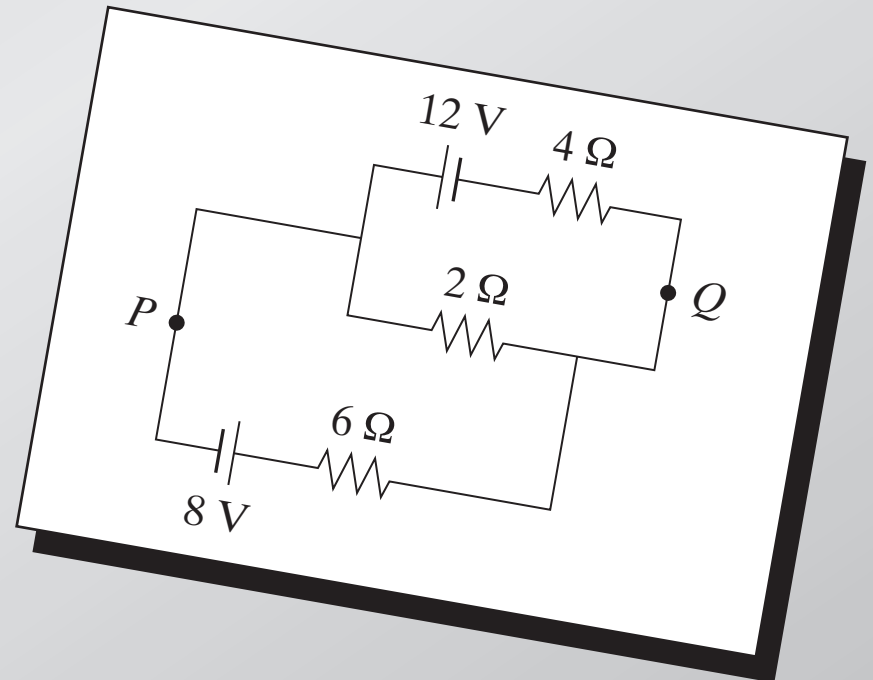

# Education

are the basic principles understood?

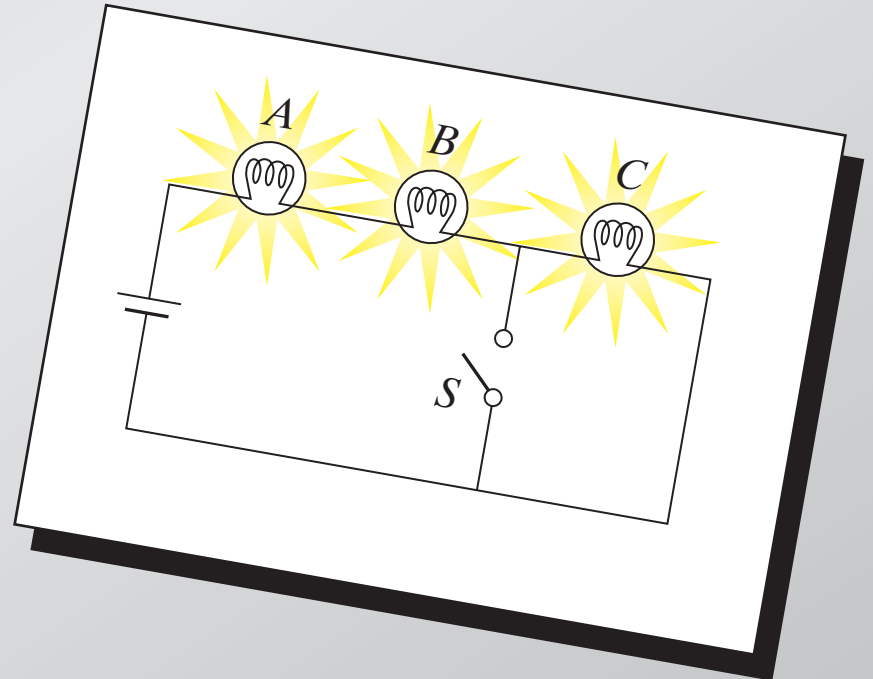

# Education

are the basic principles understood?

When  $S$  is closed, what happens to:

- (a) intensities of  $A$  and  $B$ ?
- (b) intensity of  $C$ ?
- (c) current through battery?
- (d) potential difference across  
 $A$ ,  $B$ , and  $C$ ?
- (e) the total power dissipated?

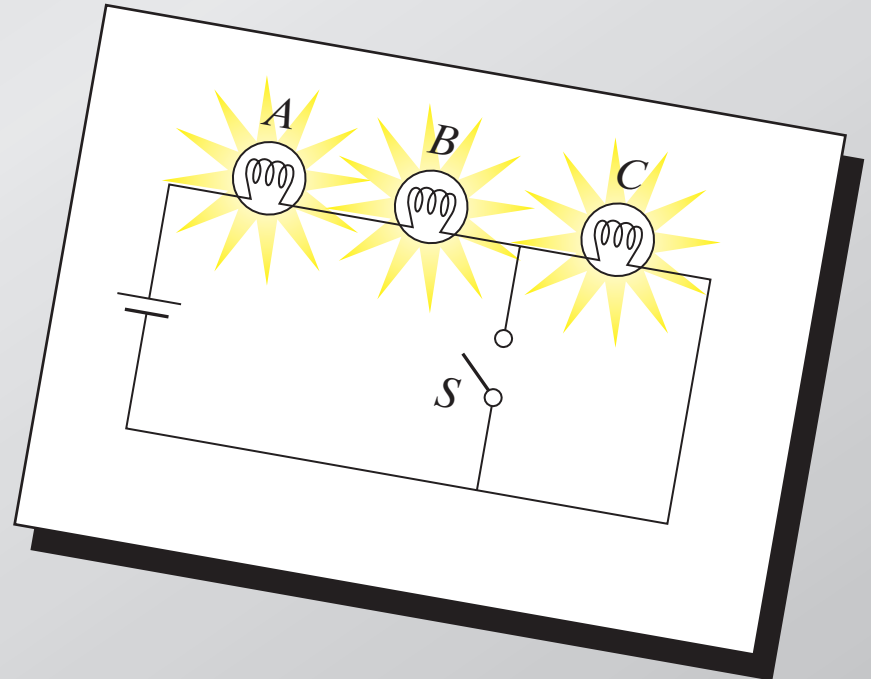

# Education

## conventional

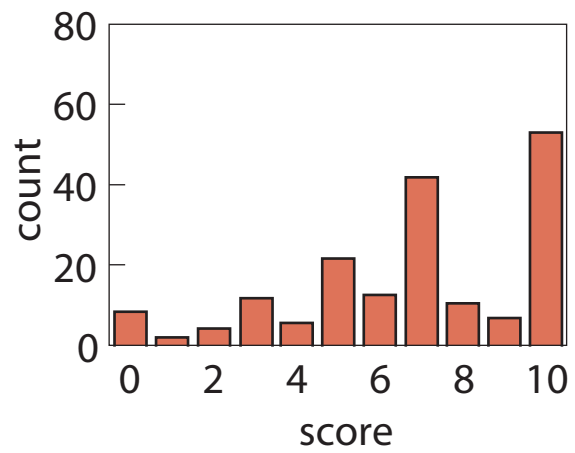

## conceptual

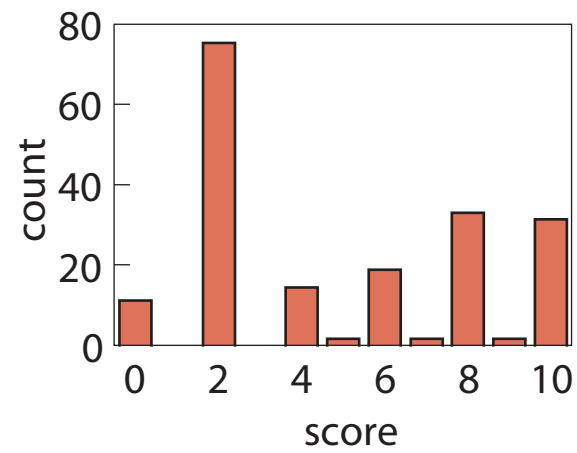

# Education

## conventional

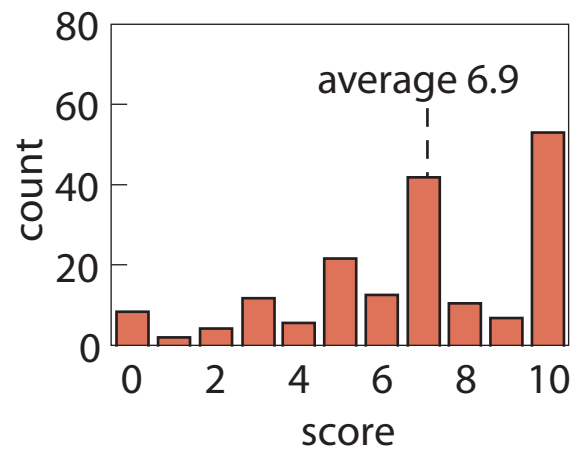

## conceptual

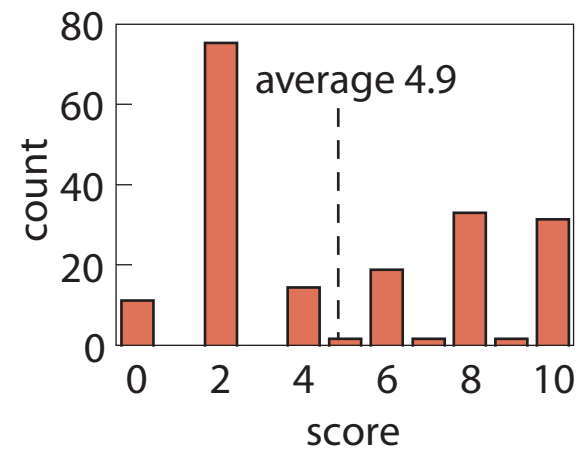

# Education

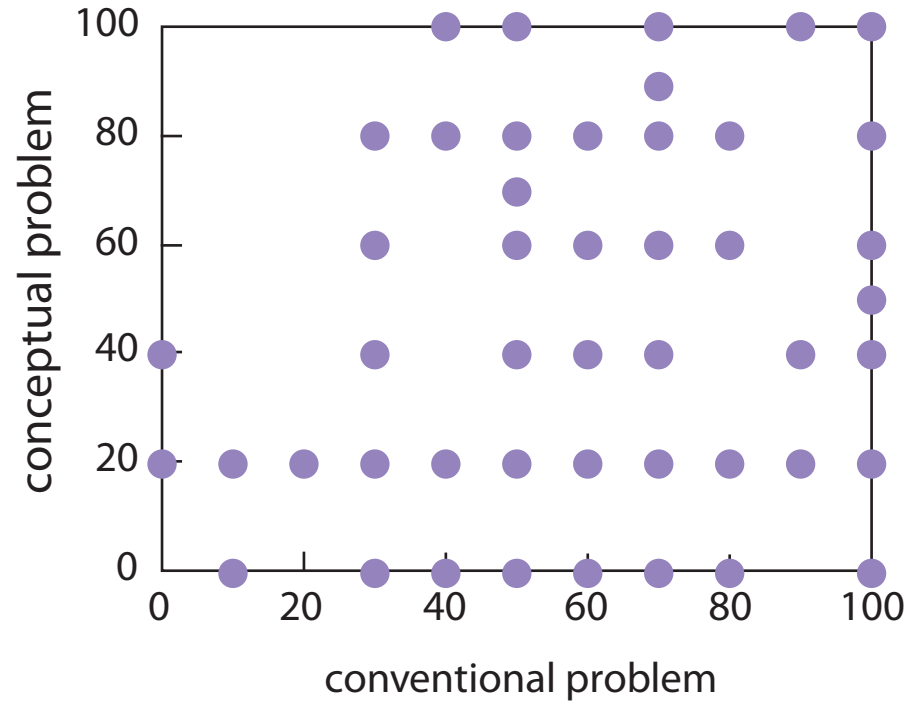

# Education

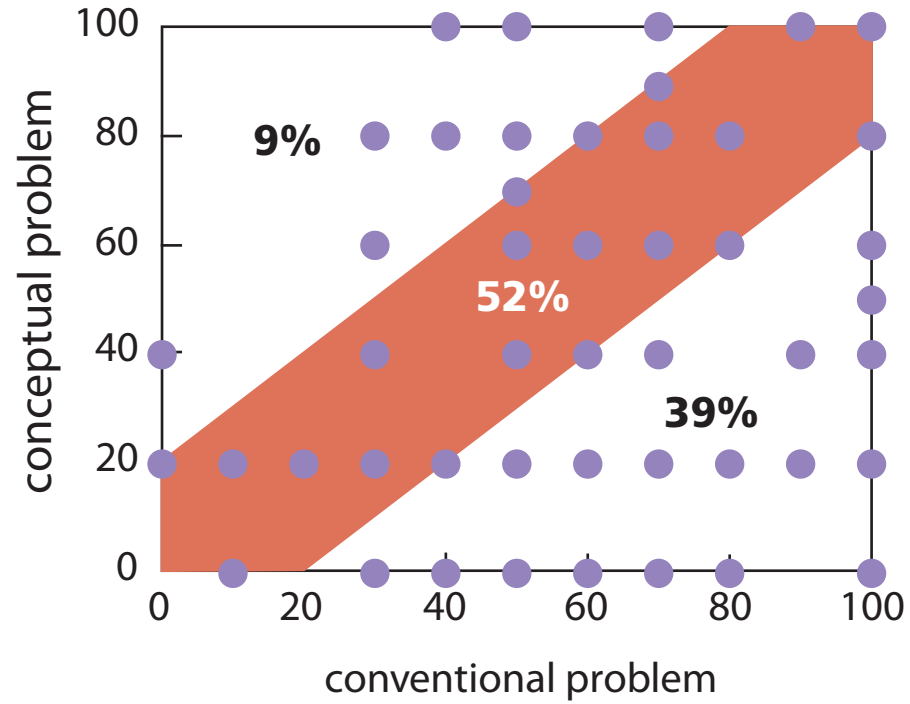



A large lecture hall with a professor at a podium and students seated at desks. A large screen at the front displays text and a diagram. The text on the screen is partially legible and includes the words "The world is full of..." and "The world is full of...". The professor is standing at a podium on the right side of the stage, facing the audience. The students are seated at desks, many with papers open. The room is dimly lit, with the main light source being the screen and the podium area.

So what should we do?

# Peer Instruction

**Give students more responsibility for gathering information...**

# Peer Instruction

**Give students more responsibility for gathering information...  
so we can better help them assimilate it.**

# Peer Instruction

## Main features:

- pre-class reading
- in-class: depth, not 'coverage'
- ConcepTests

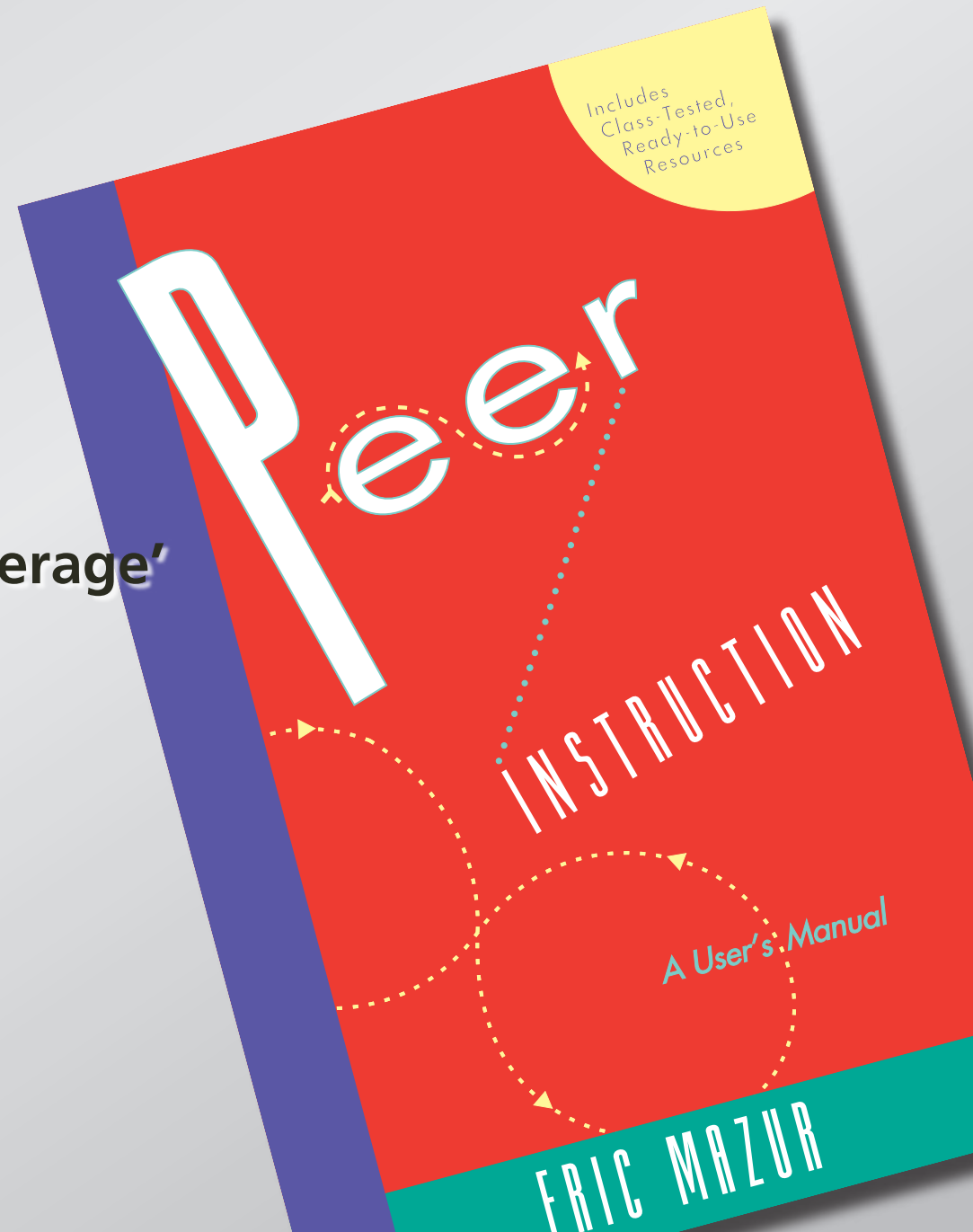

# Peer Instruction

**ConcepTest:**

- 1. Question**
- 2. Thinking**
- 3. Individual answer**
- 4. Peer discussion**
- 5. Revised/Group answer**
- 6. Explanation**



# Results

is it any good?

# Results

## first year of implementing PI

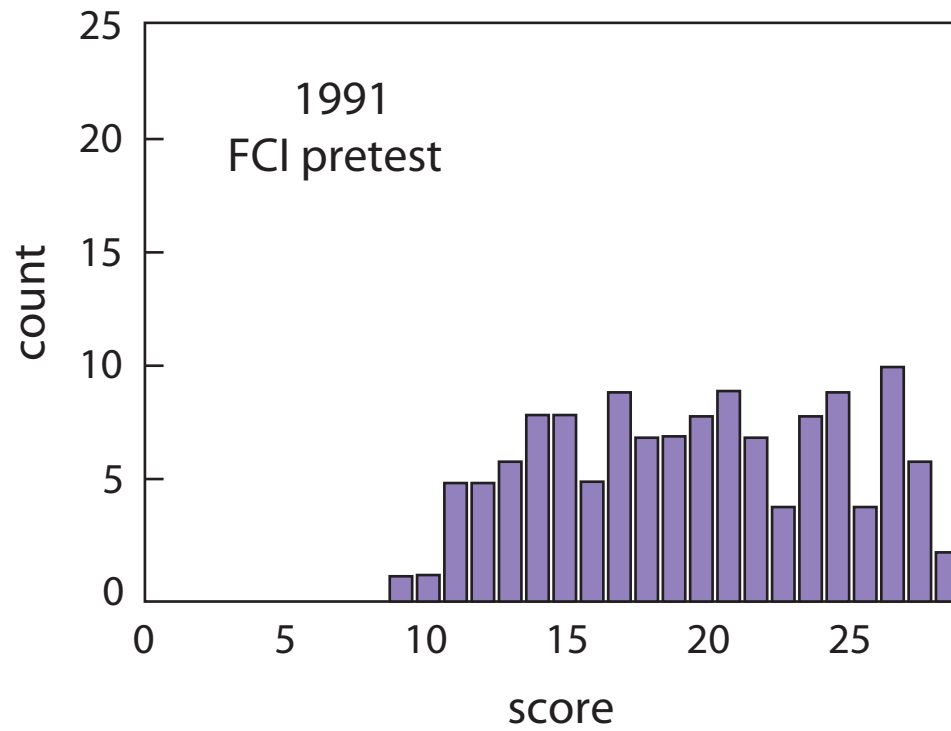



# Results

## first year of implementing PI

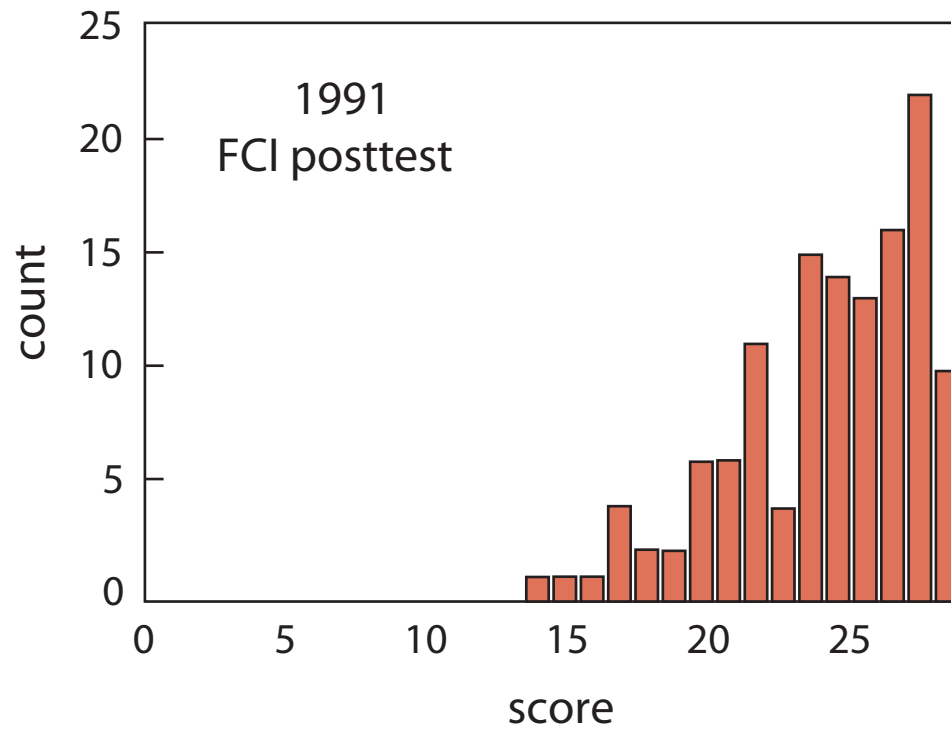

# Results

## first year of implementing PI

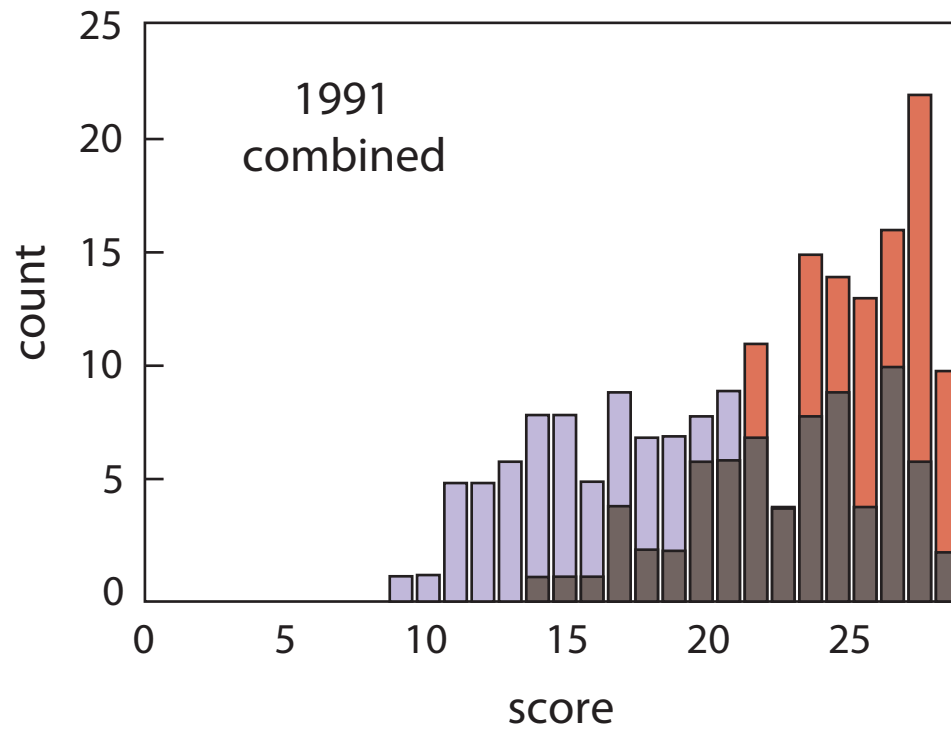

# Results

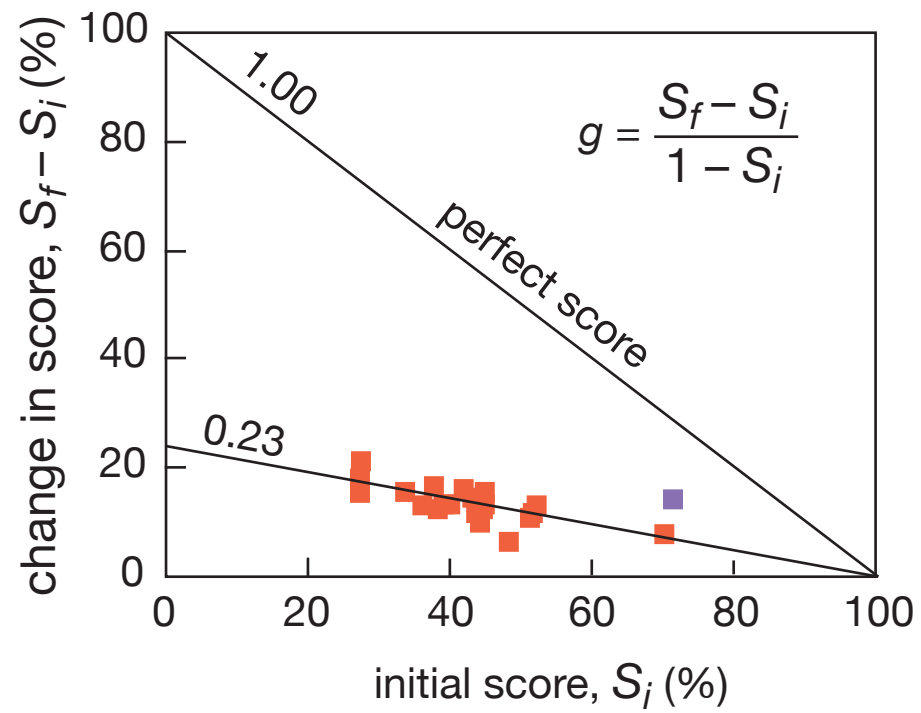

# Results

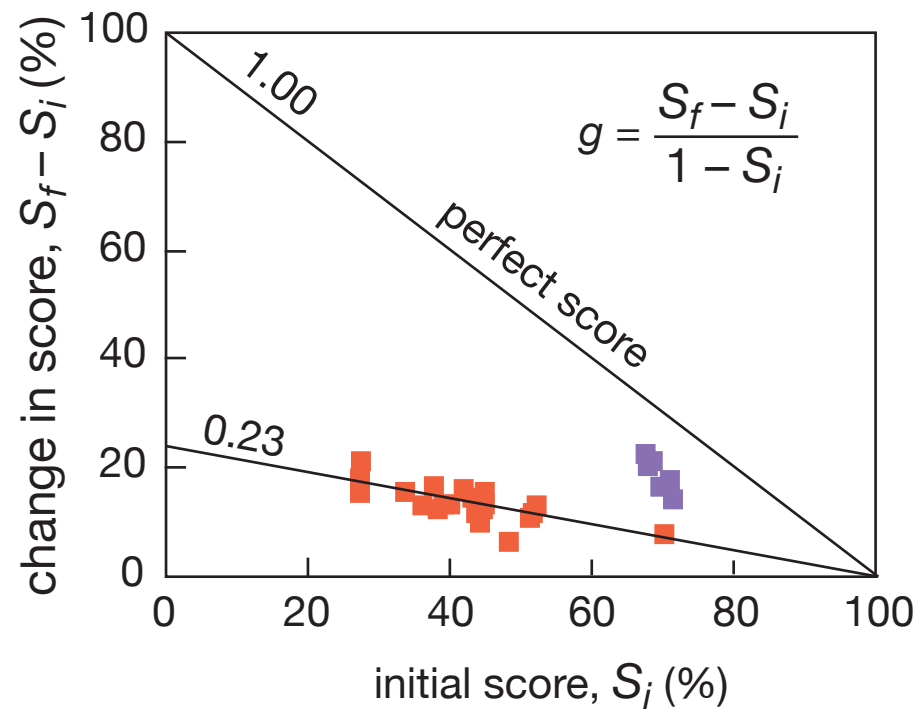

# Results

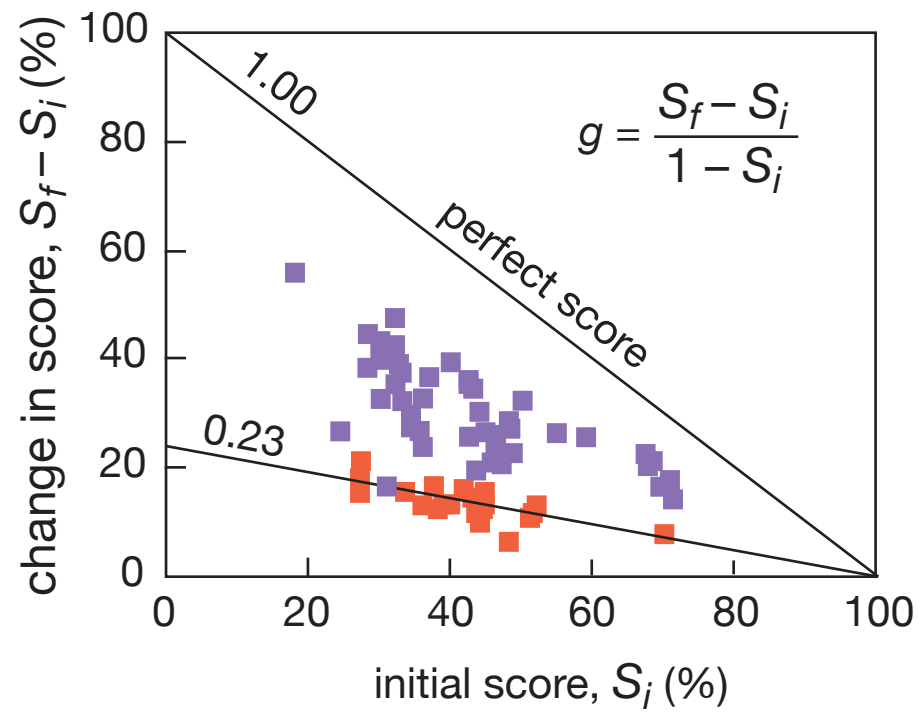

# Results

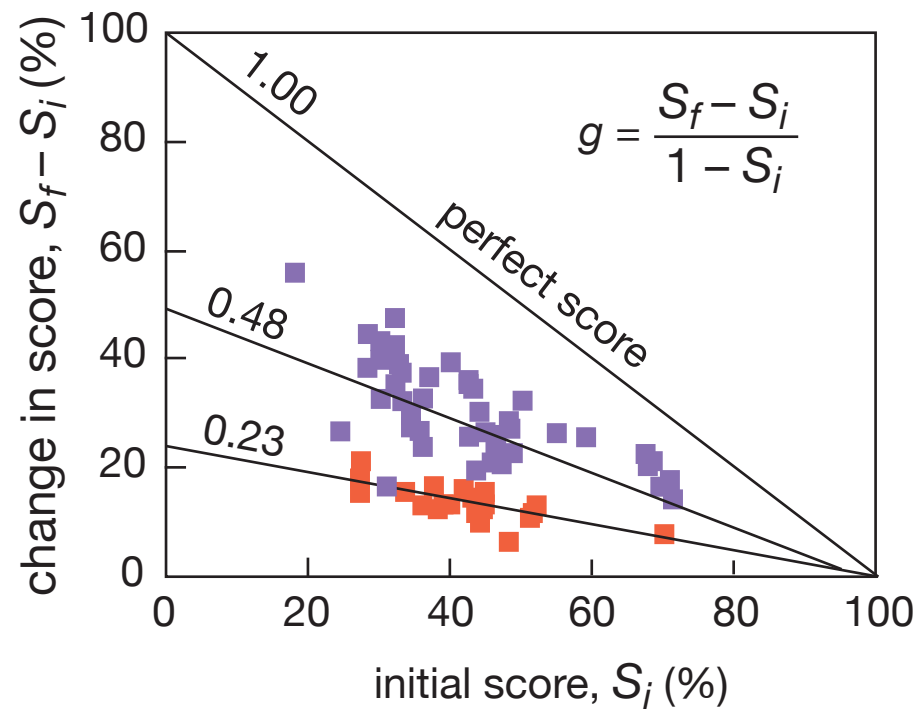

# Results

**what about problem solving?**

# Results

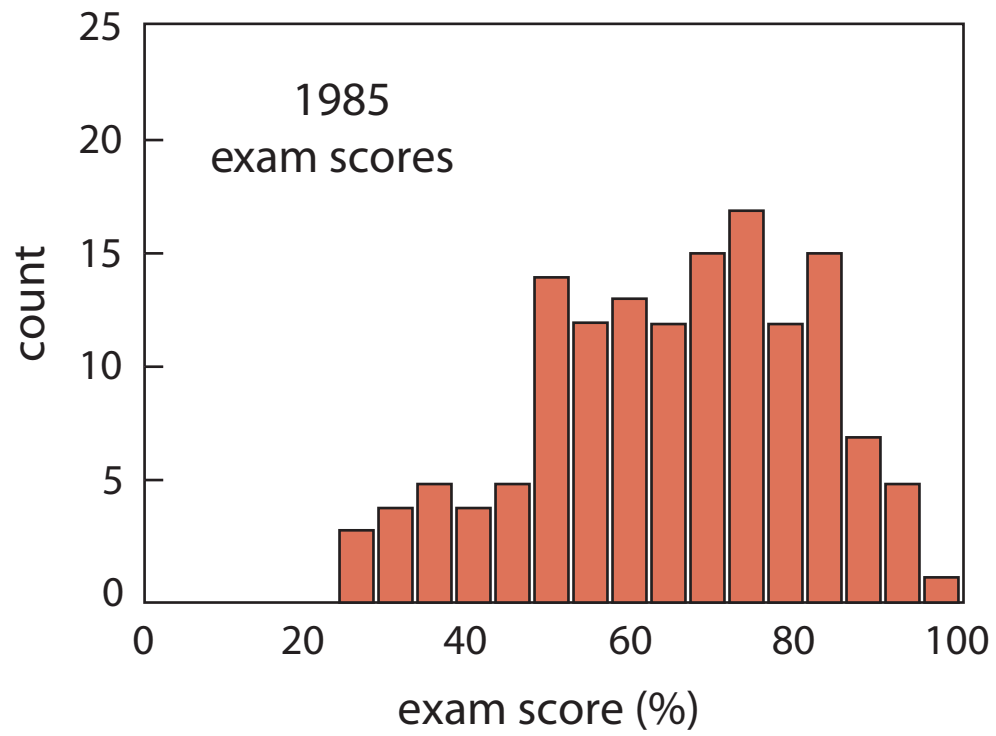



# Results

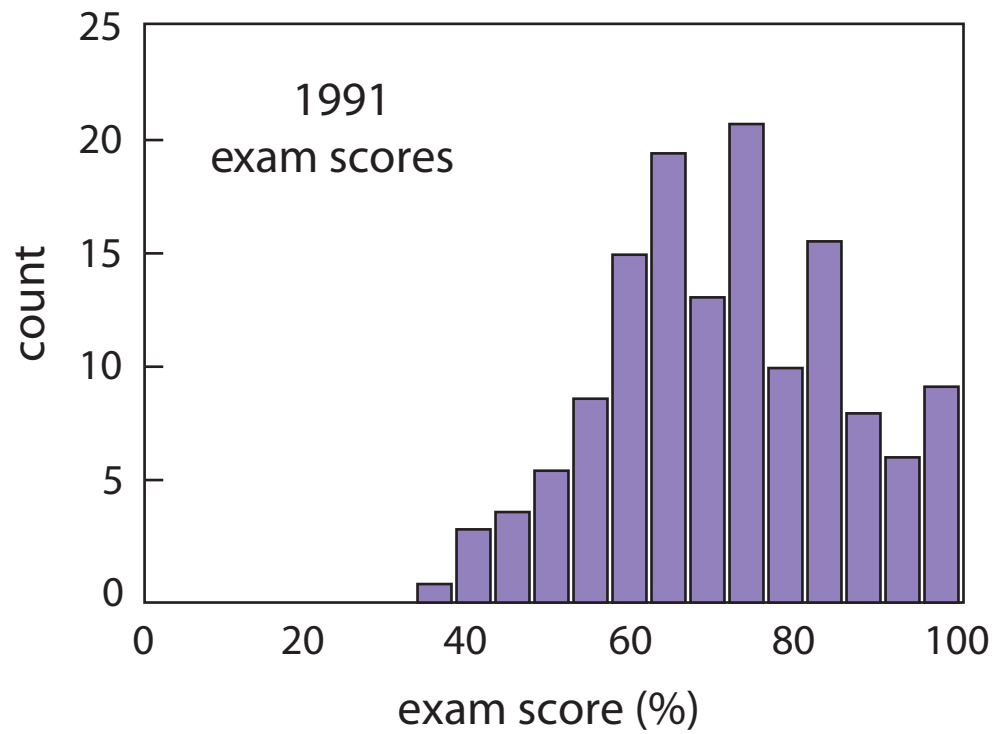

# Results

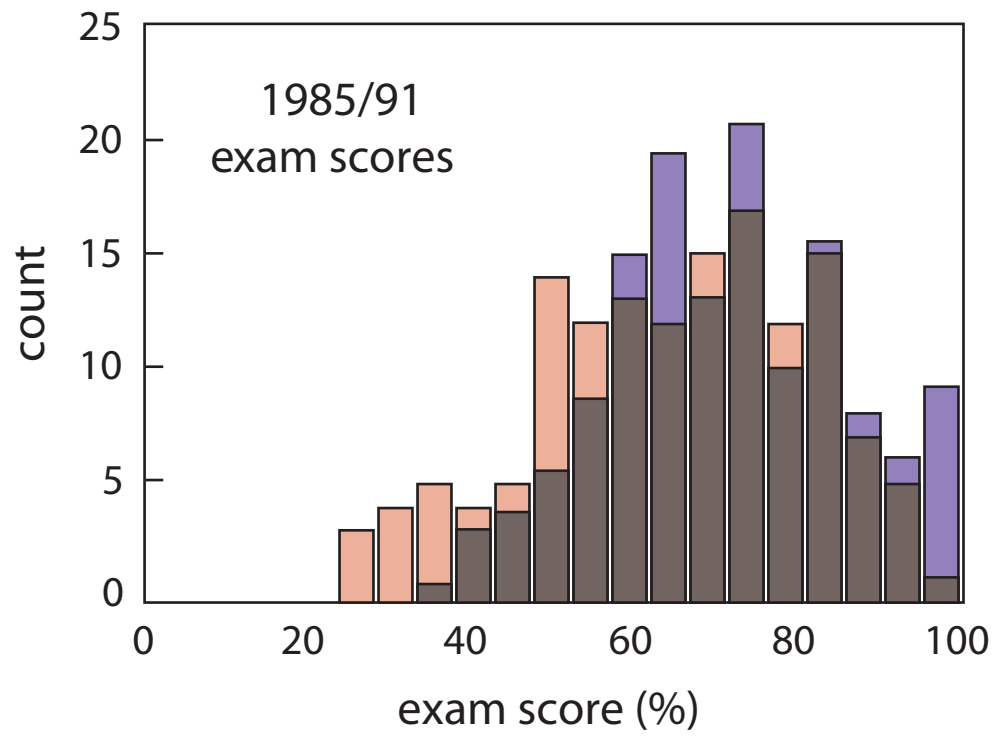

# Summary

**So better understanding leads to better  
problem solving!**

# Summary

**So better understanding leads to better problem solving!**

**(but “good” problem solving doesn’t always indicate understanding!)**

# Summary

**Traditional indicators of success misleading**

# Summary

**Traditional indicators of success misleading**

**Education is no longer about information**



**Funding:**

**National Science Foundation**

**for a copy of this presentation:**

**<http://mazur-www.harvard.edu>**



Google™

Google Search

I'm Feeling Lucky

Google™

mazur

Google Search

I'm Feeling Lucky

# Google™

Google Search

I'm Feeling Lucky

# Google™

Google Search

I'm Feeling Lucky

**Funding:**

**National Science Foundation**

**for a copy of this presentation:**

**<http://mazur-www.harvard.edu>**