

Memorization or understanding: are we teaching the right thing?



China-US Advanced Forum on Physics Education
Tsing Hua University
Beijing, China, 6 August 2012



Innovation

Nobel Prize in Physics 2010

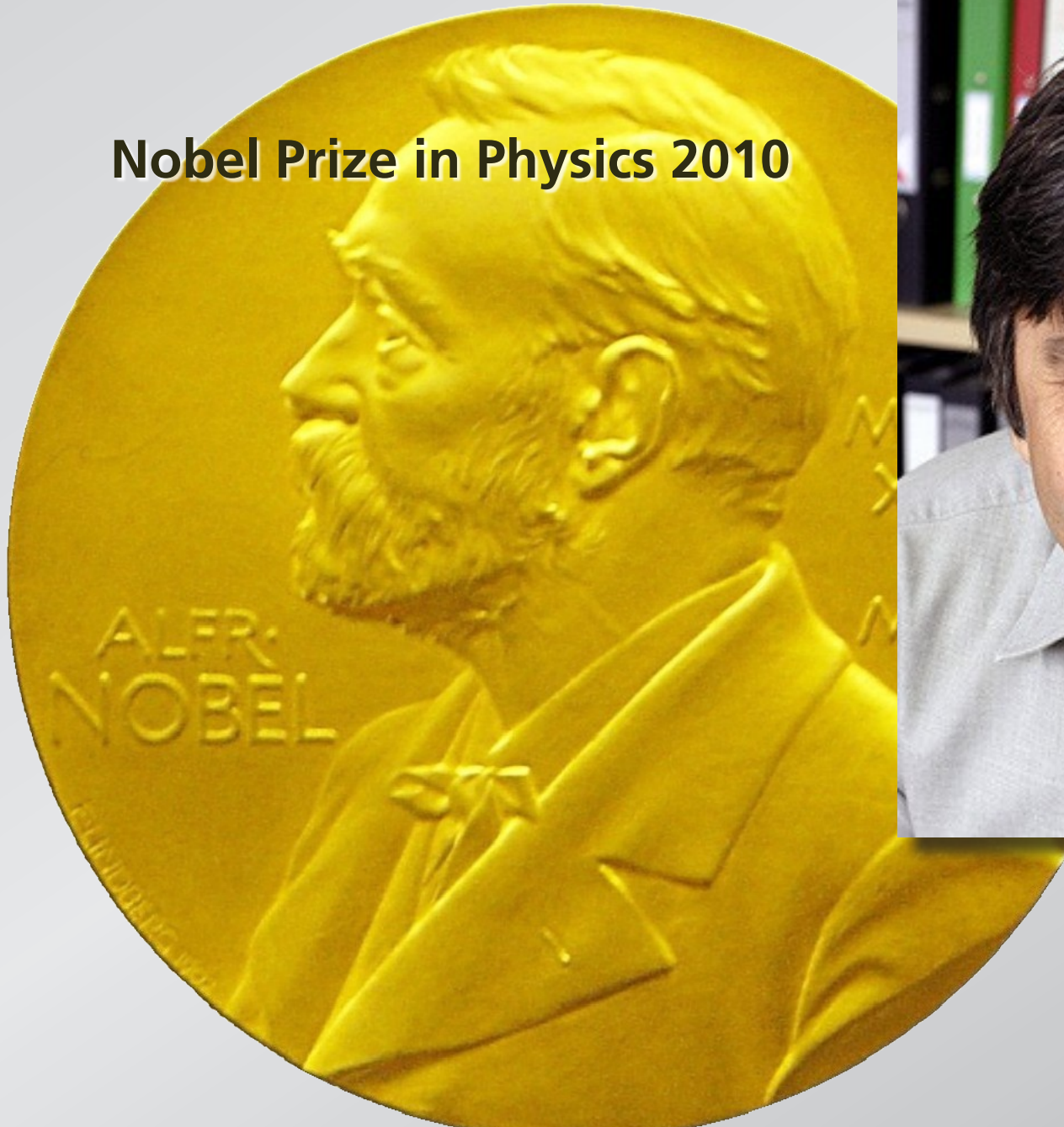

Nobel Prize in Physics 2010

Ig Nobel Prize in 2000

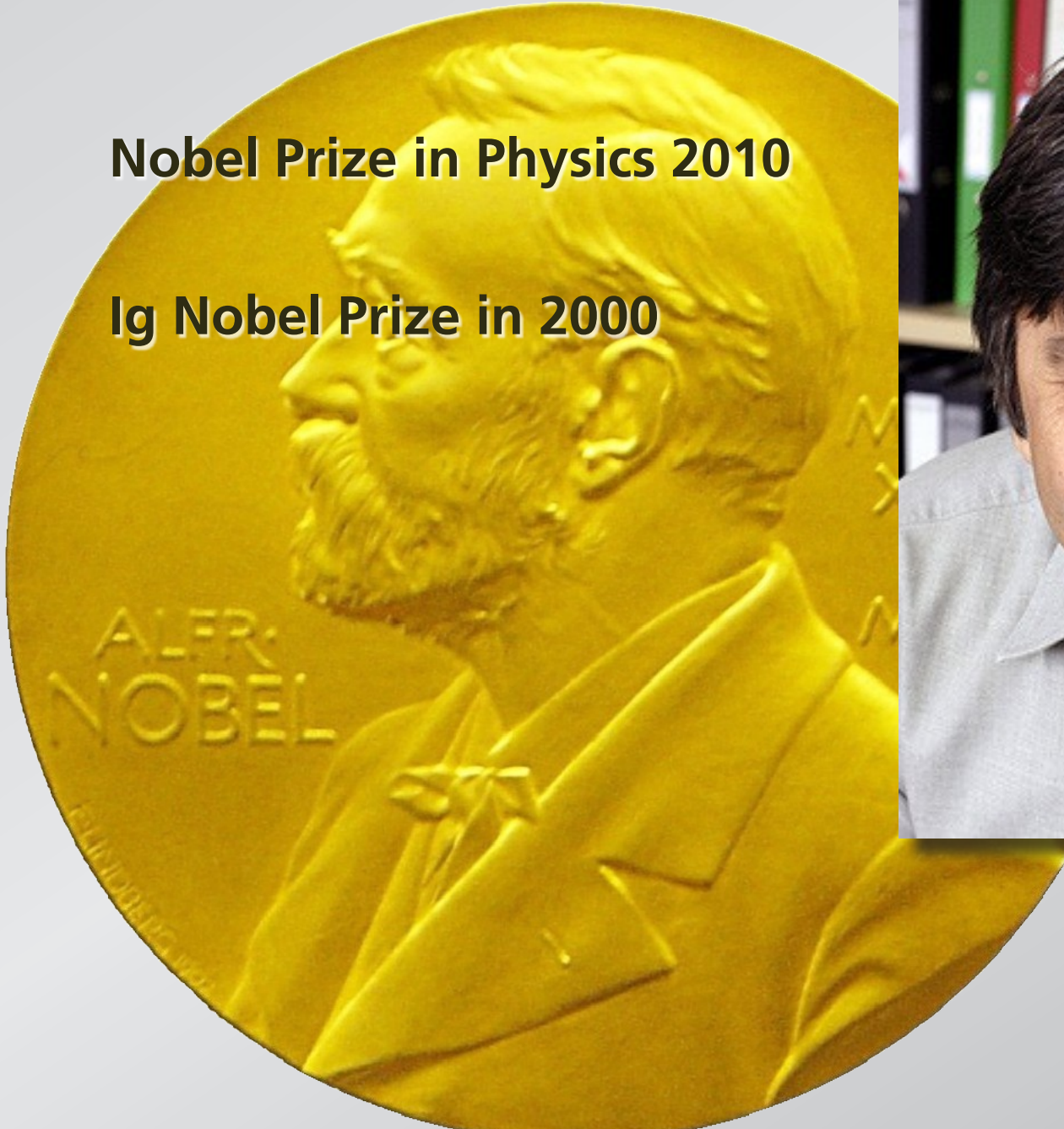

**“For me it’s very boring to work
on the same thing year after year...”**

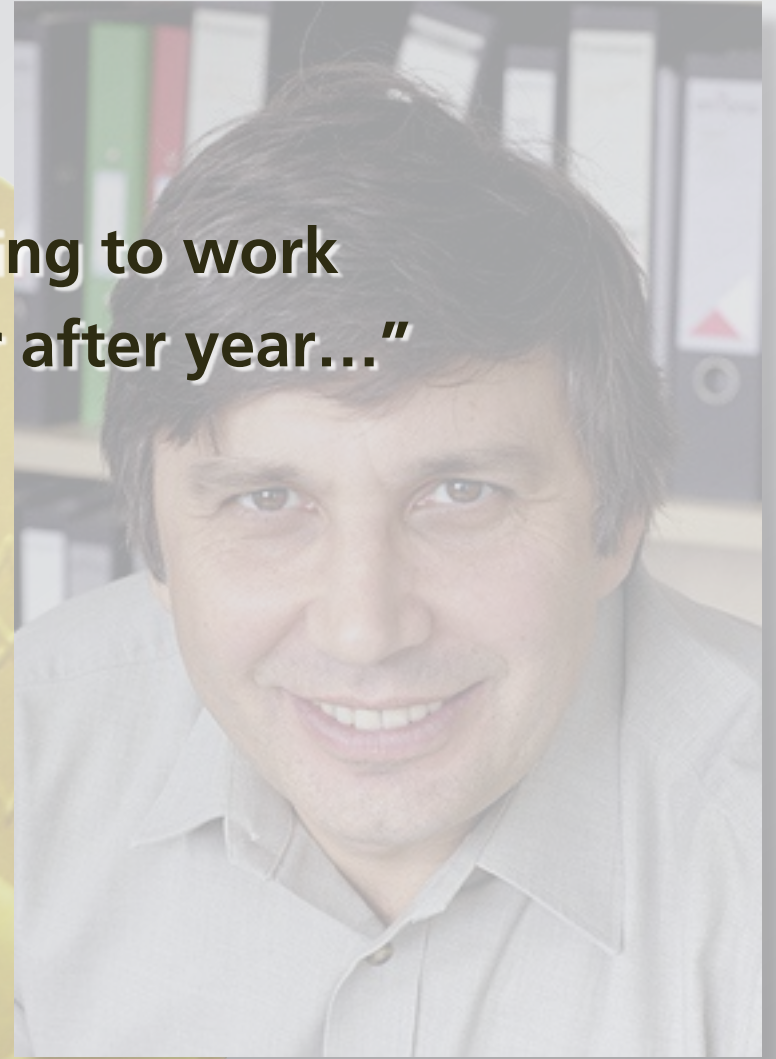

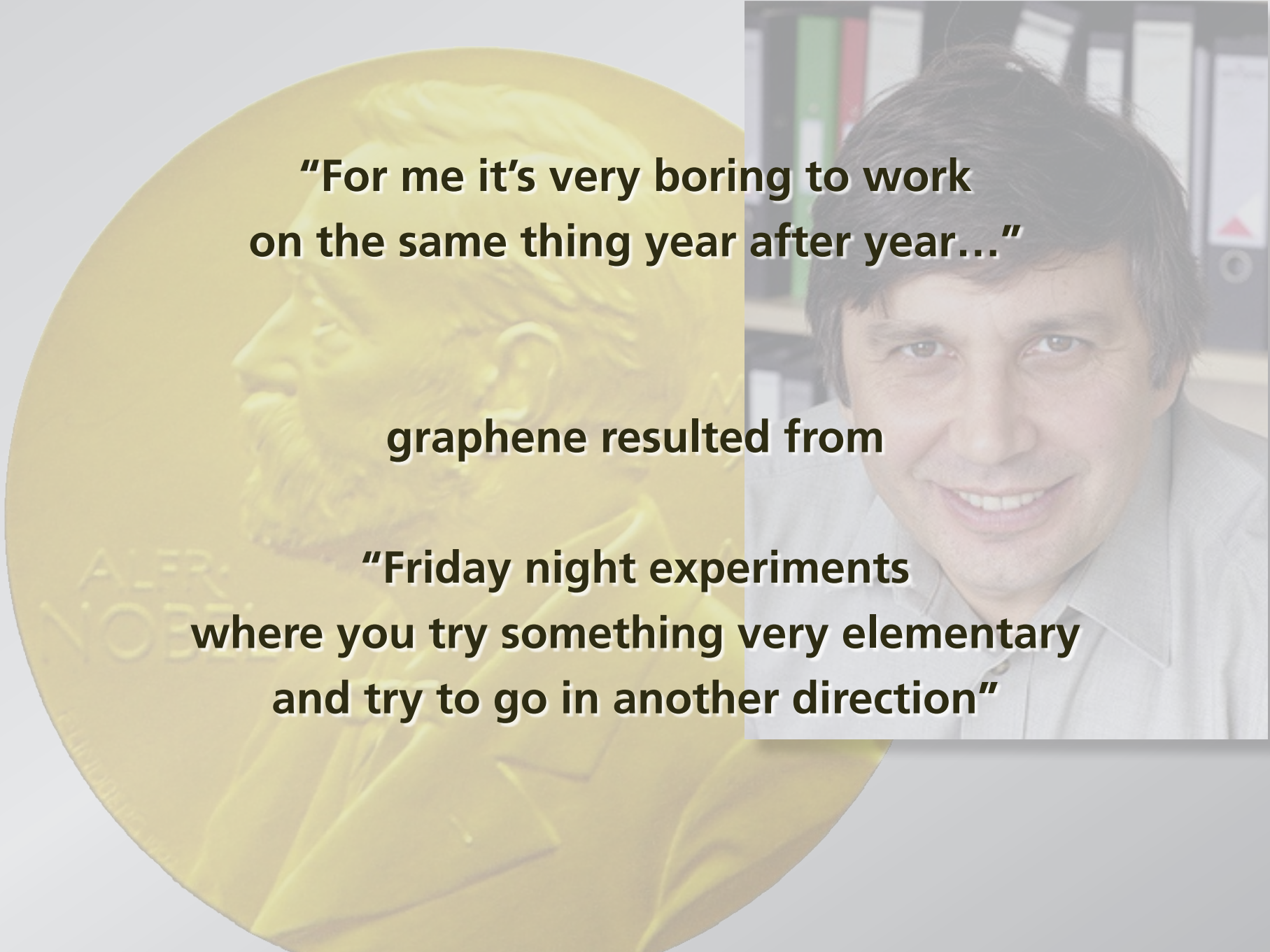

**“For me it’s very boring to work
on the same thing year after year...”**

graphene resulted from

**“Friday night experiments
where you try something very elementary
and try to go in another direction”**

A glowing lightbulb with a filament, symbolizing an idea or innovation. The lightbulb is the central focus, with a warm, yellowish glow emanating from it. The filament is visible, and the glass of the bulb is slightly textured. The background is a soft, gradient yellow.

how can we foster/teach innovation?



Need to...

- **teach *problem* solving**
- **encourage risk taking**

Think of something you are good at

EDUCACION

Think of something you are good at

How did you become good at this?

EDUCACION







1 education

2 PI



1 education

2 PI

3 results

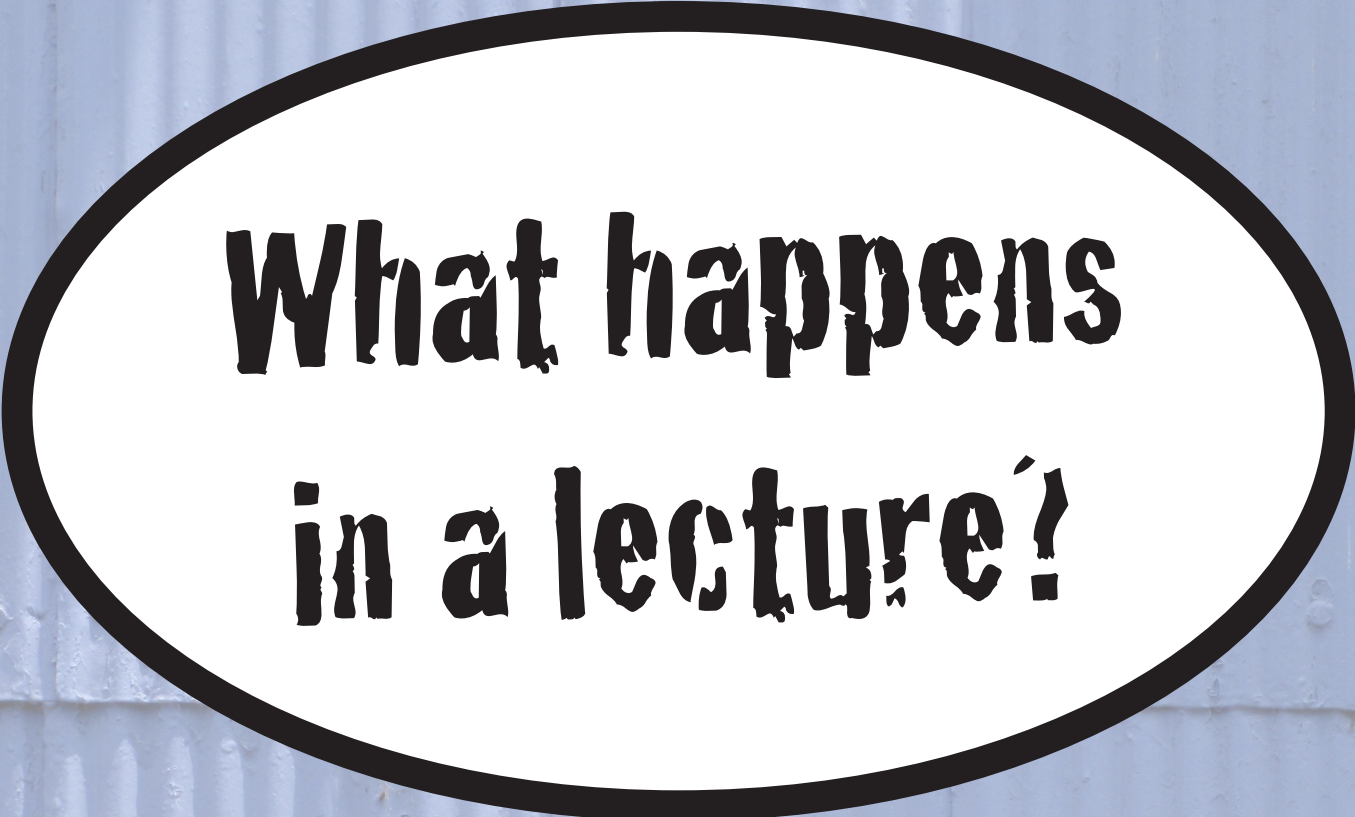
A large white thought bubble with a thick black border is centered in the upper half of the image. It contains the text 'What happens in a lecture?'. Below the main bubble are three smaller white circles with black borders, arranged in a diagonal line from bottom-left to top-right, leading up to the main bubble.

**What happens
in a lecture?**



A large lecture hall with students seated at desks, facing a stage where a lecturer is standing. The room has a curved wall and a large screen at the front. The text "some people talk in their sleep" is overlaid on the image.

some people talk in their sleep

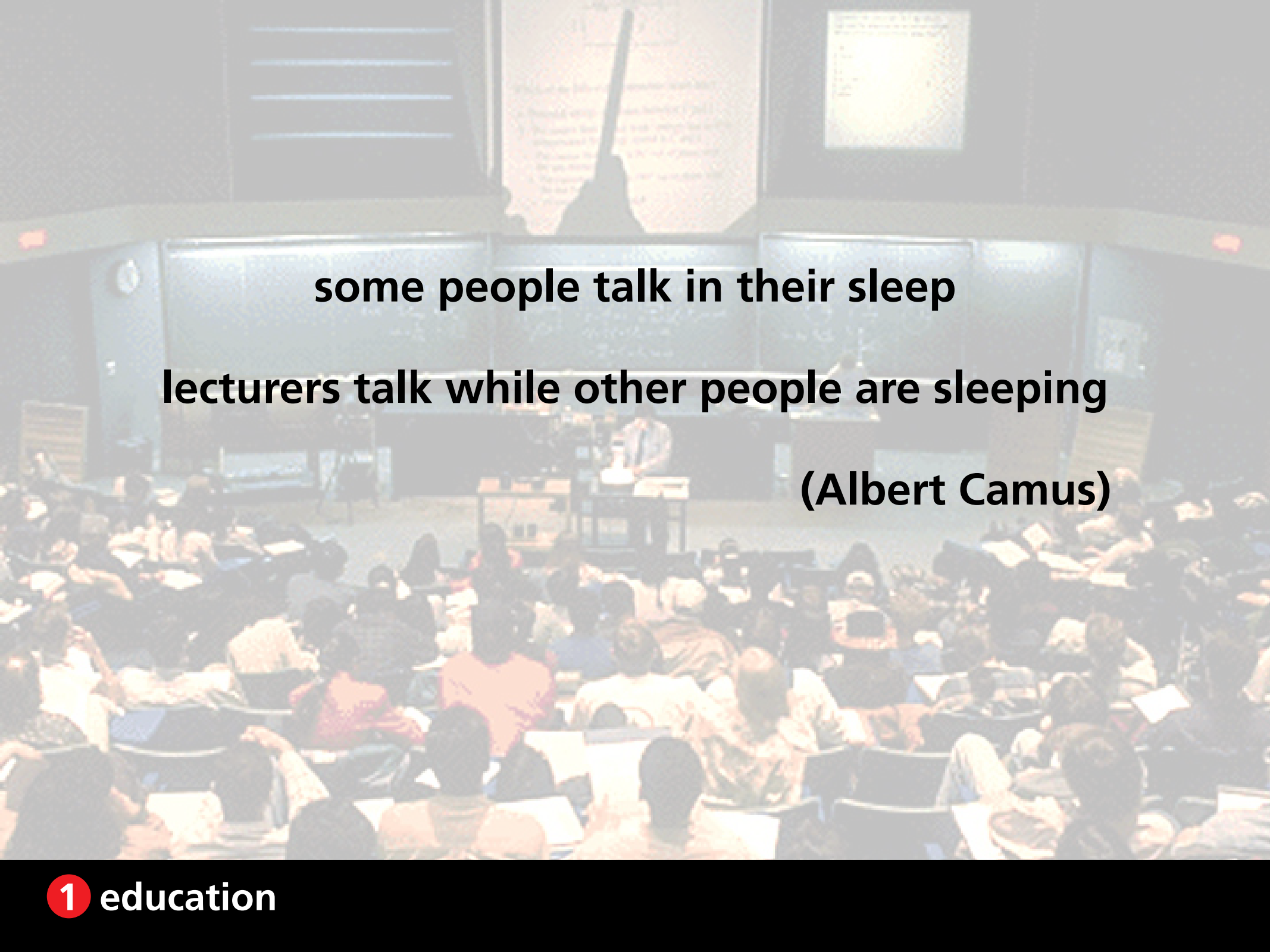

some people talk in their sleep
lecturers talk while other people are sleeping
(Albert Camus)



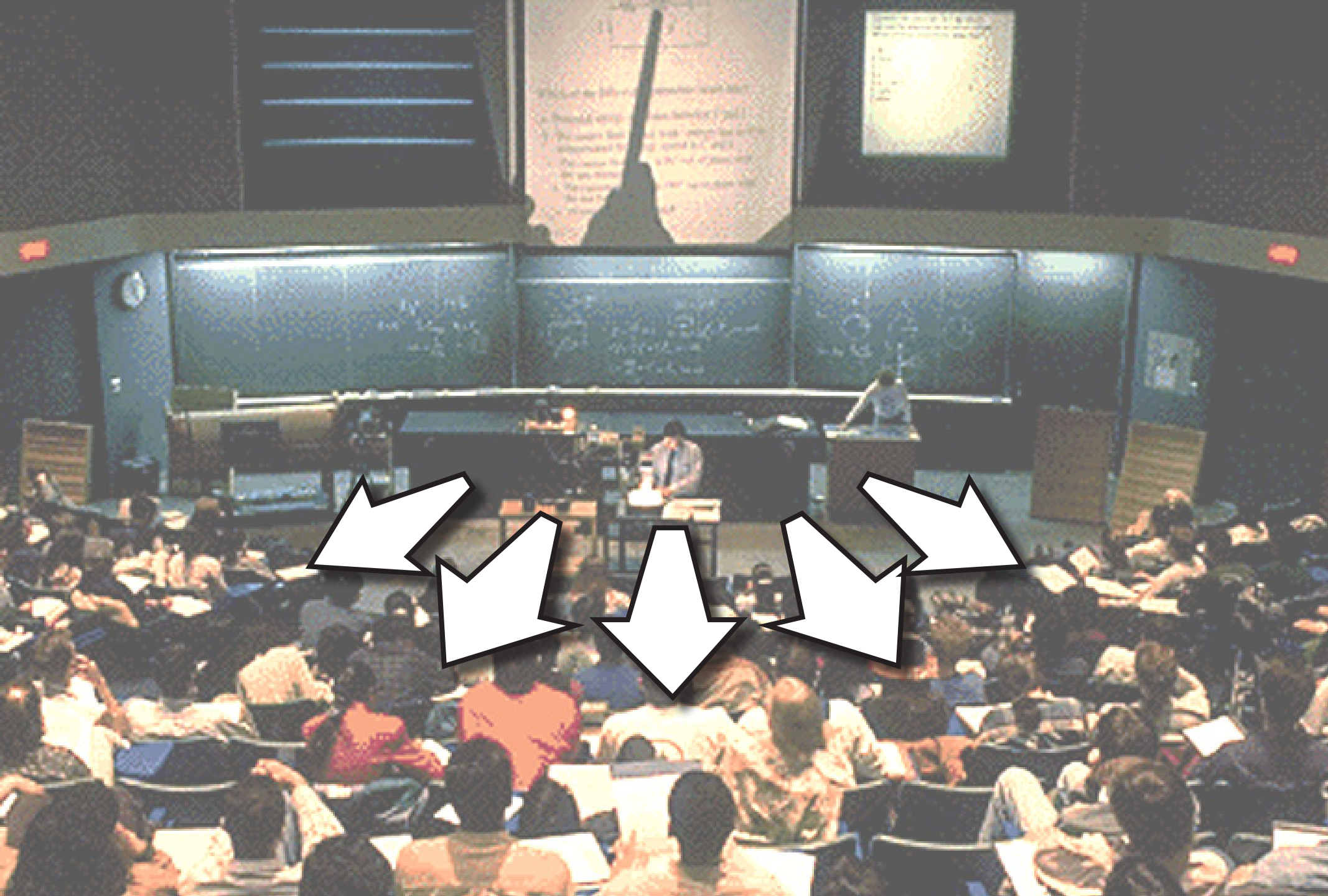

The result?

EDUCACION

education is not just information transfer

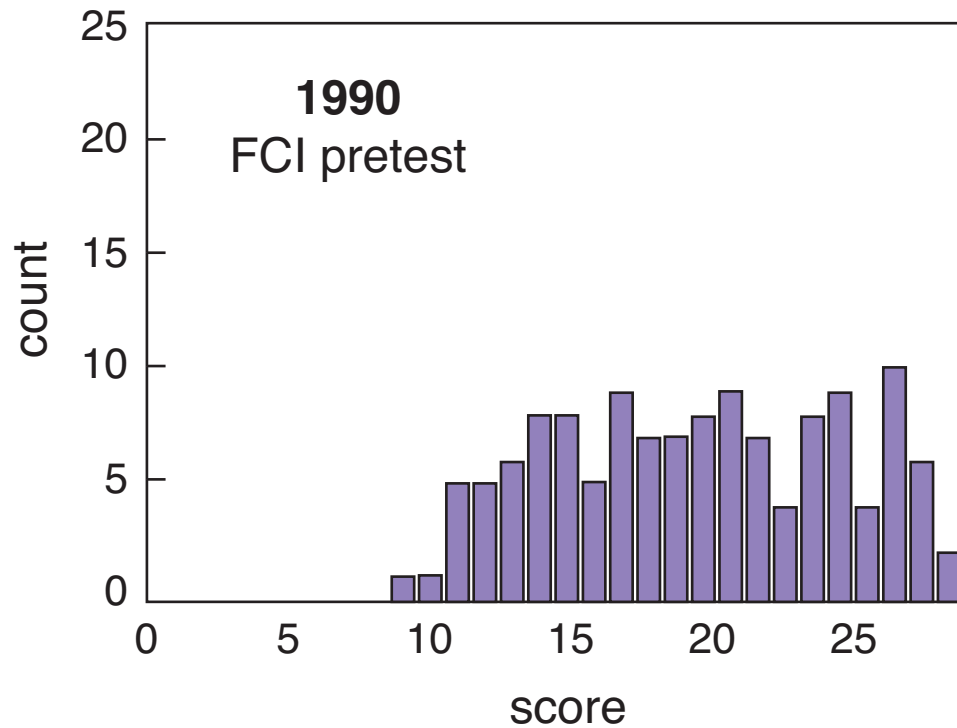

education is not just information transfer

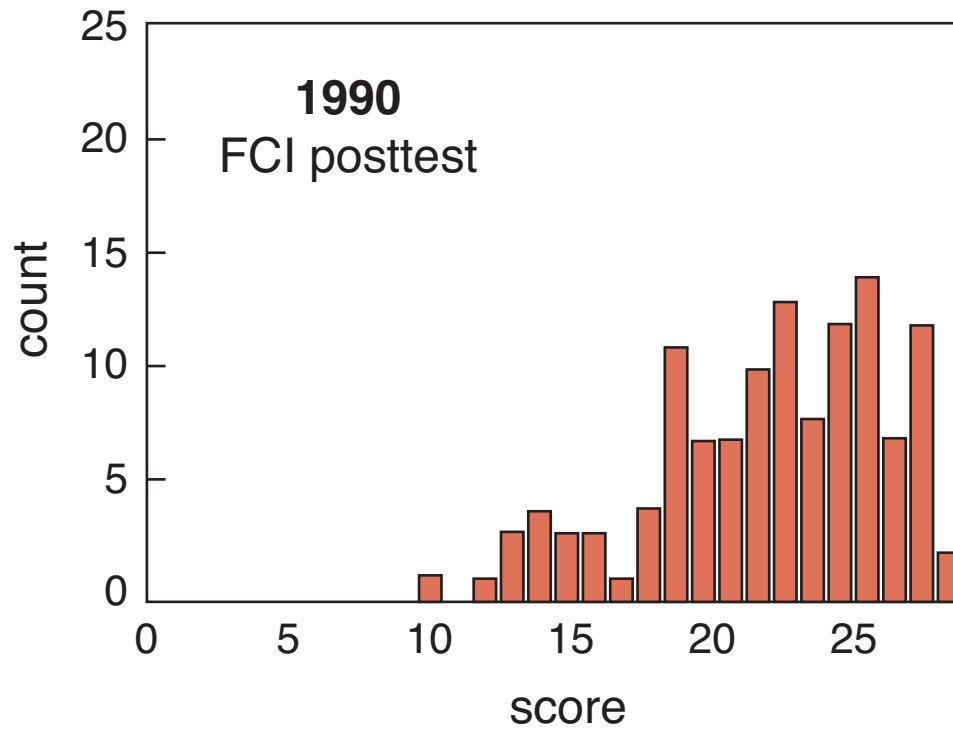

education is not just information transfer

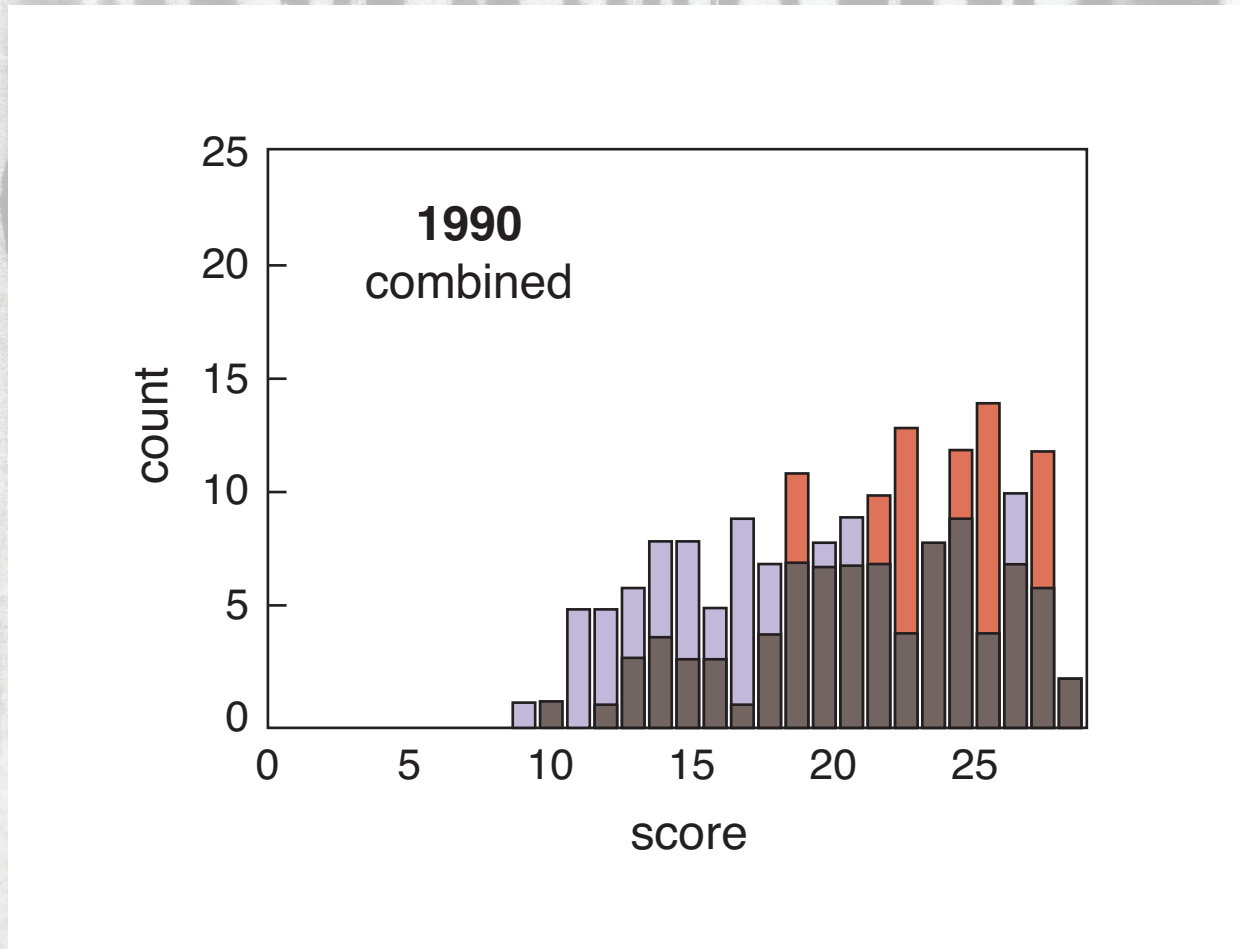

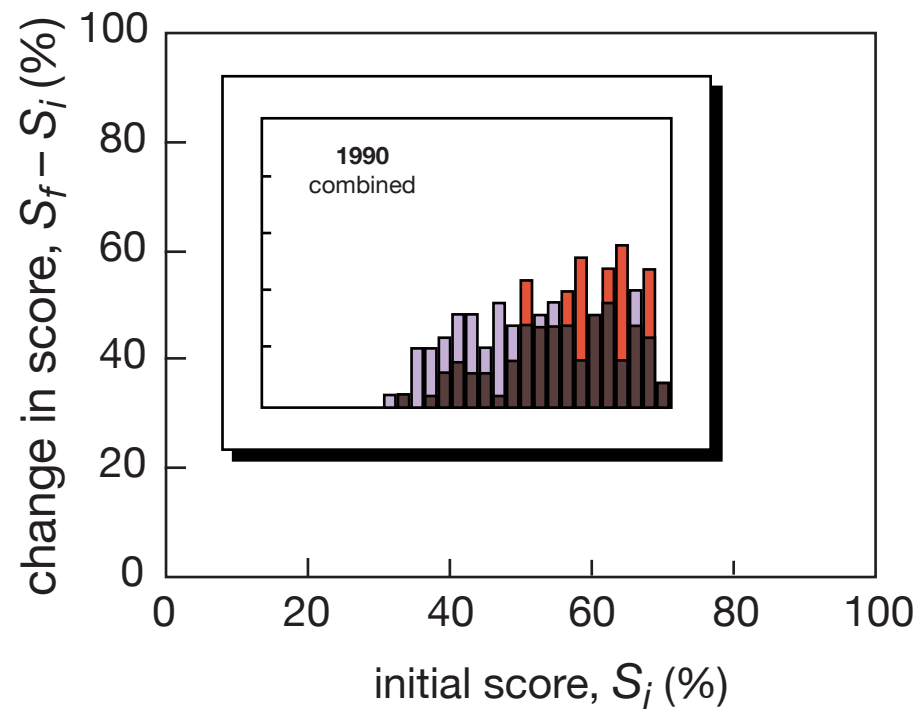

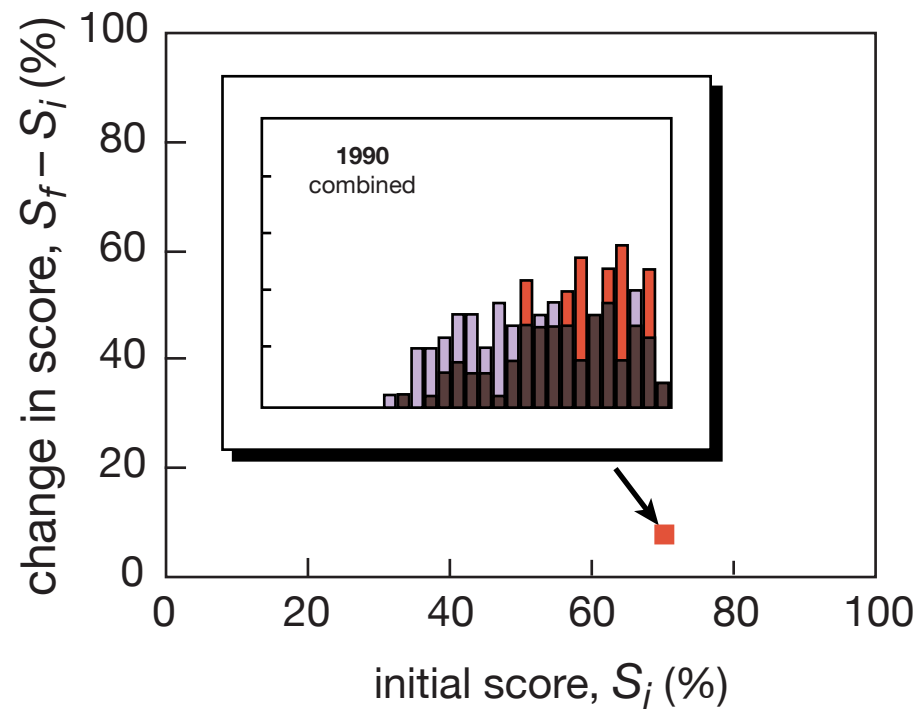

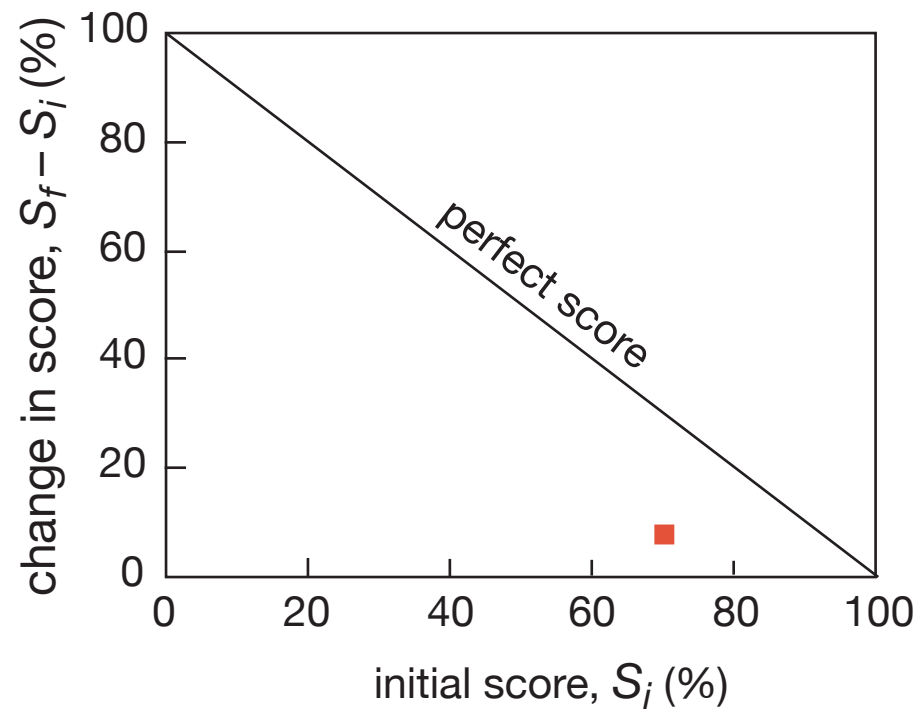

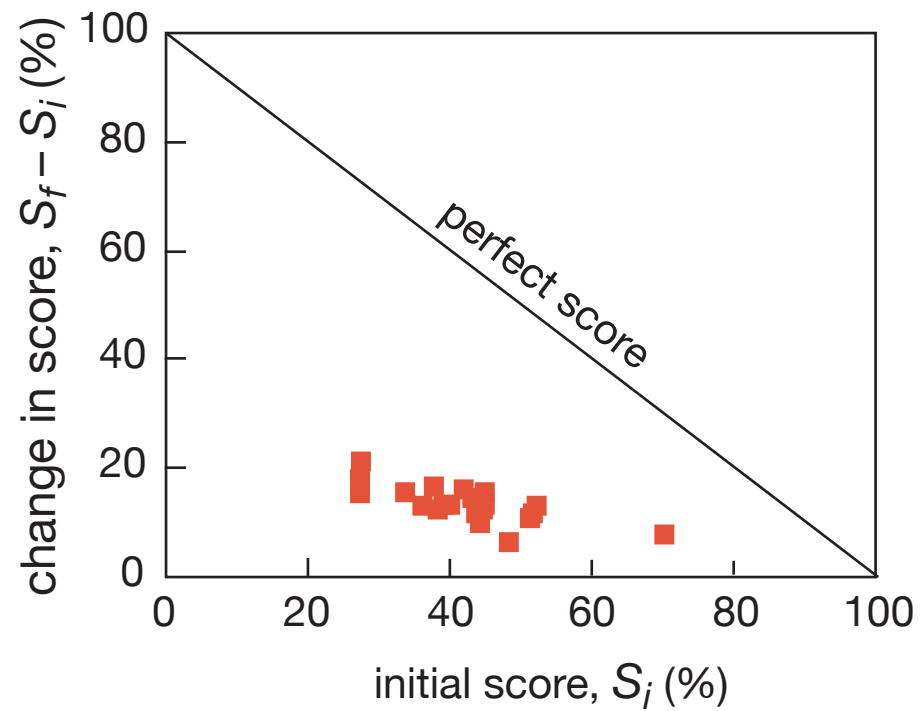

R.R. Hake, *Am. J. Phys.* 66, 64 (1998)

only one quarter of maximum gain realized

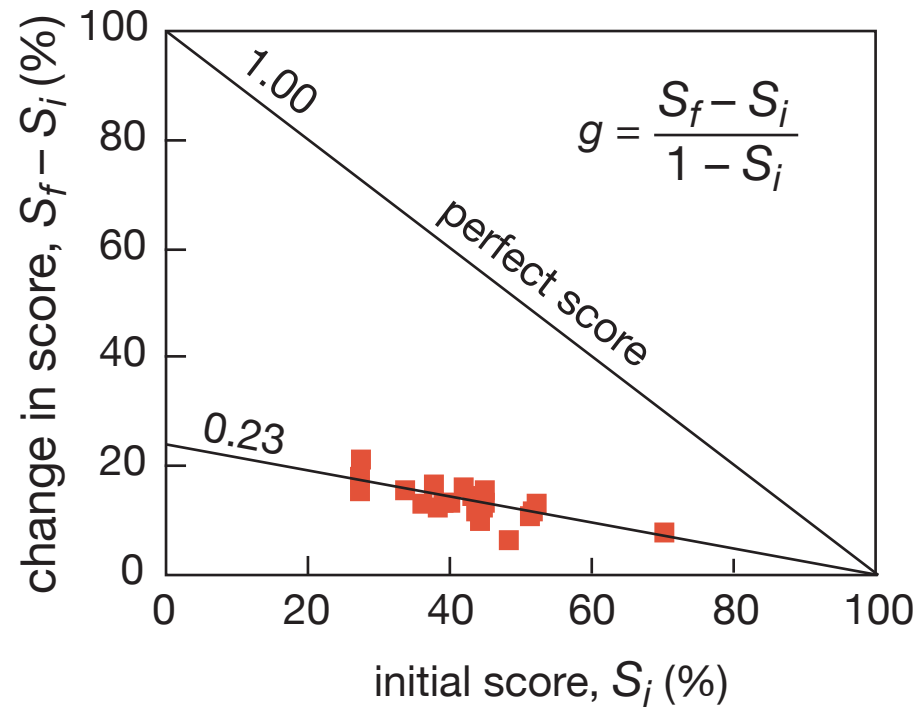

R.R. Hake, *Am. J. Phys.* 66, 64 (1998)

not transfer but assimilation of information is key

EDUCACION

conventional problems misleading

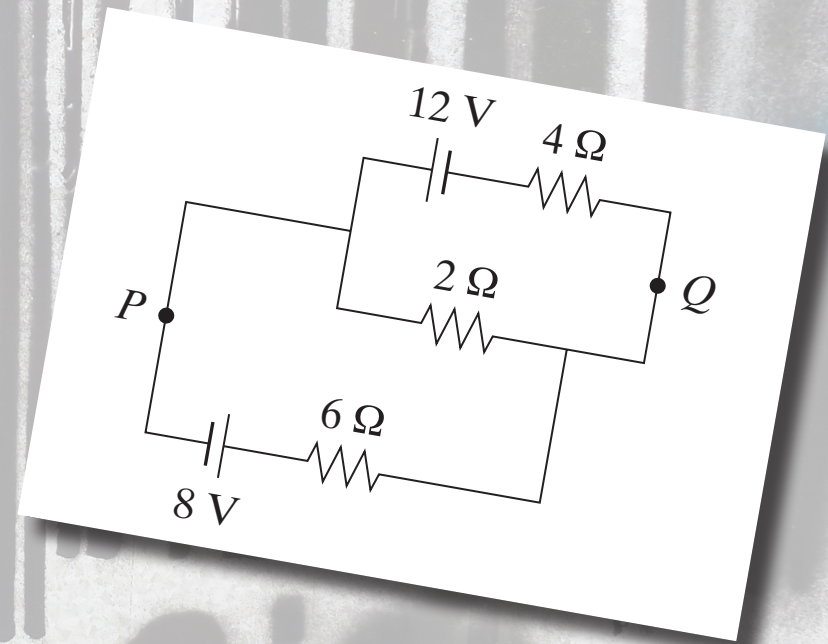

conventional problems misleading

Calculate:

(a) current in $2\text{-}\Omega$ resistor

(b) potential difference
between P and Q

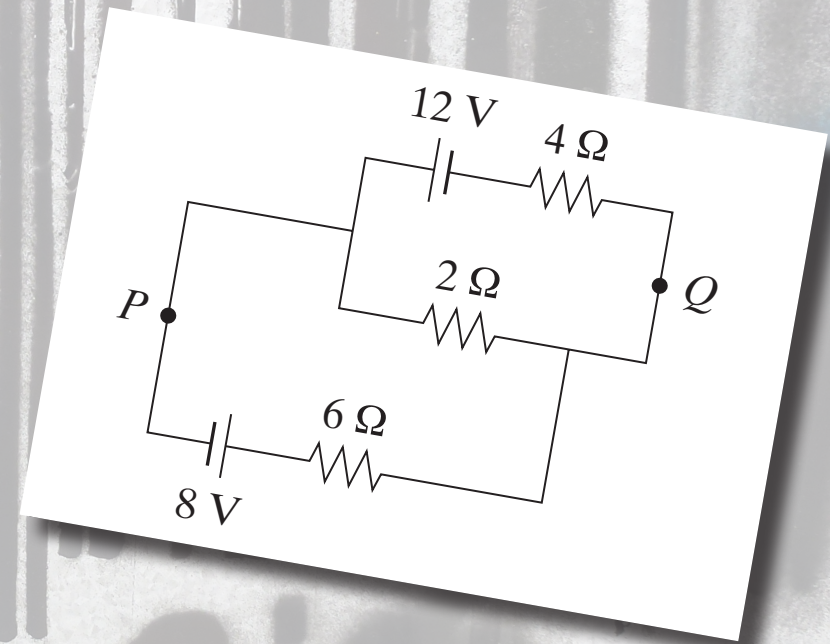

are the basic principles understood?

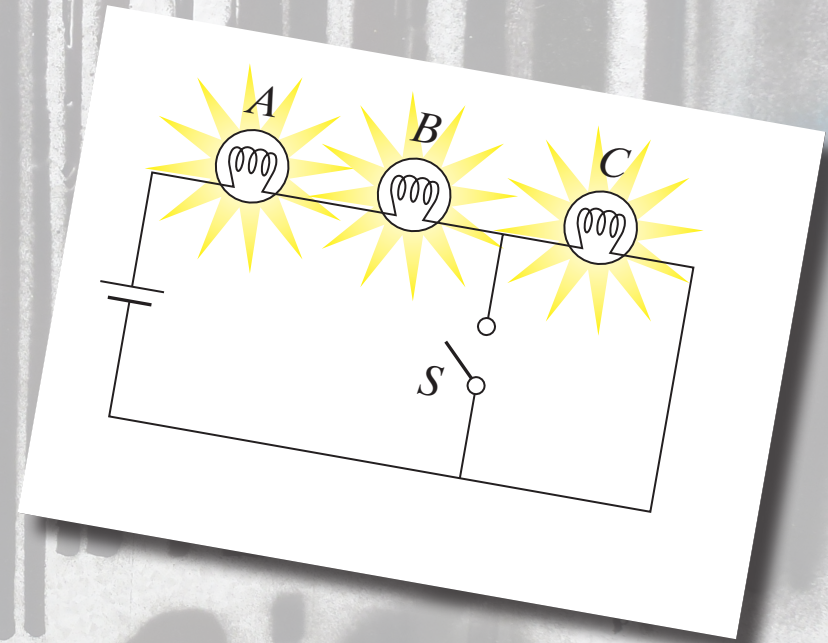

are the basic principles understood?

When S is closed, what happens to:

- (a) intensities of A and B ?
- (b) intensity of C ?
- (c) current through battery?
- (d) potential difference across A , B , and C ?
- (e) the total power dissipated?

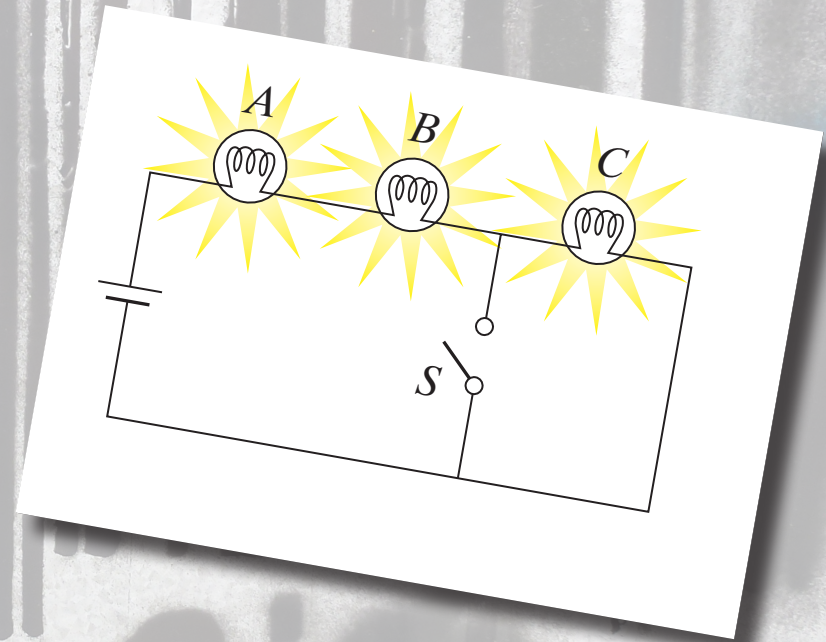

conventional

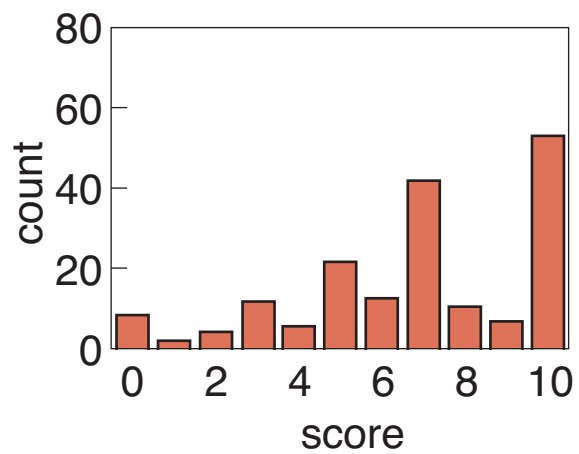

conceptual

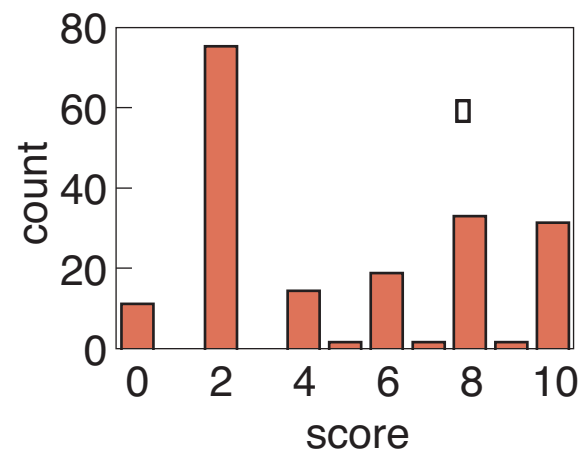

conventional

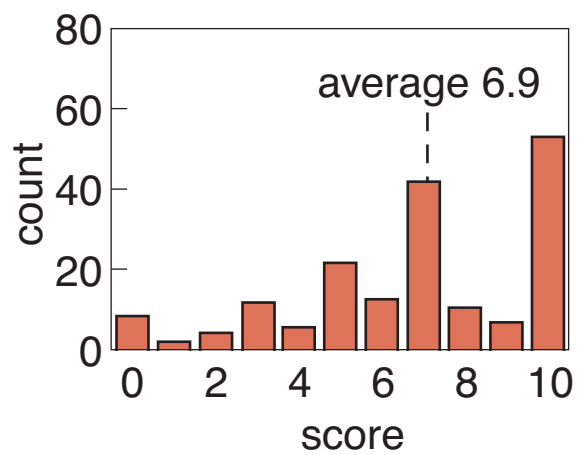

conceptual

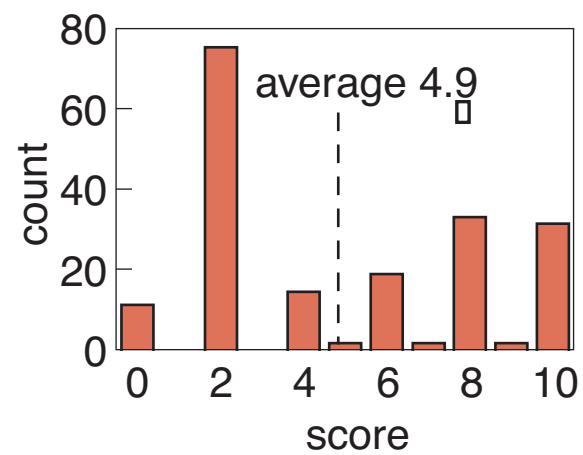

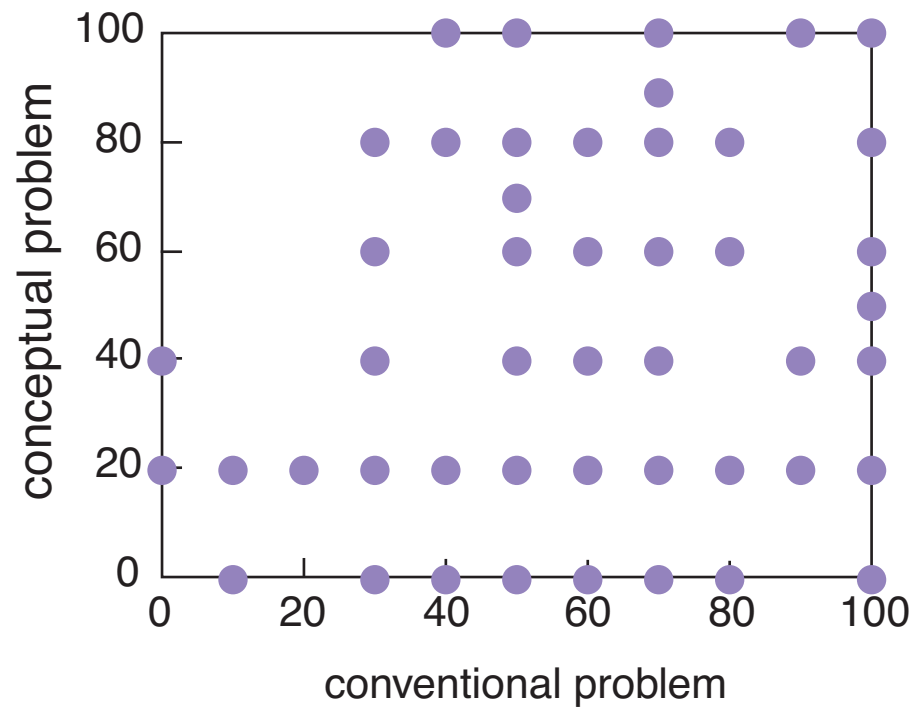

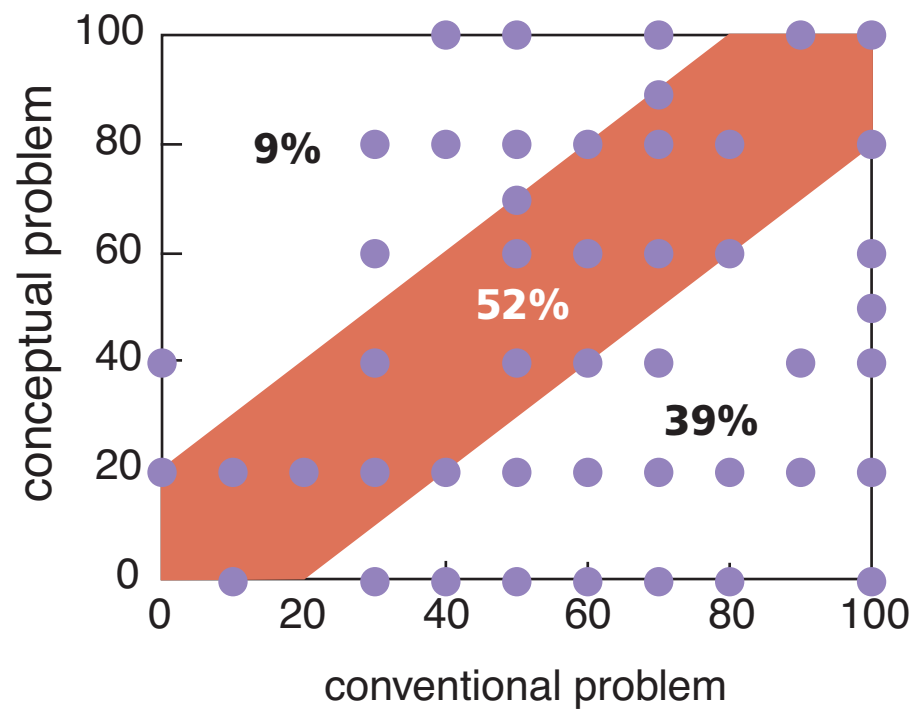

Lack of learning

EDUCACION

Lack of learning

Lack of retention





1. transfer of information



1. transfer of information

2. assimilation of that information



1. transfer of information (in class)

2. assimilation of that information



1. transfer of information (in class)

2. assimilation of that information (out of class)



**Should focus
on THIS!**

1. transfer of information (in class)

2. assimilation of that information (out of class)



1. transfer of information (in class)

2. assimilation of that information (out of class)



1. transfer of information (out of class)

2. assimilation of that information (in class)

Peer



1. transfer of information (out of class)

2. assimilation of that information (in class)

INSTRUCTION

question

1 education

2 PI

question



think

question



think



poll

question



think



poll



discuss

question



think



poll



discuss



repoll

question



think



poll



discuss



repoll



explain

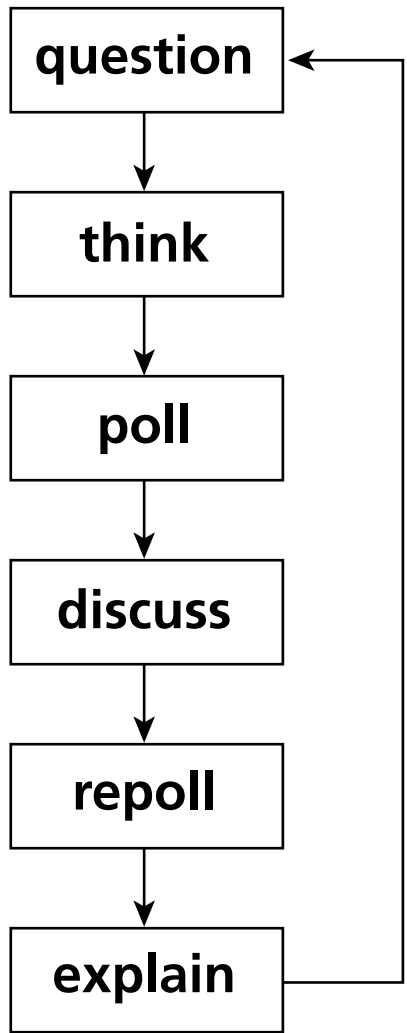

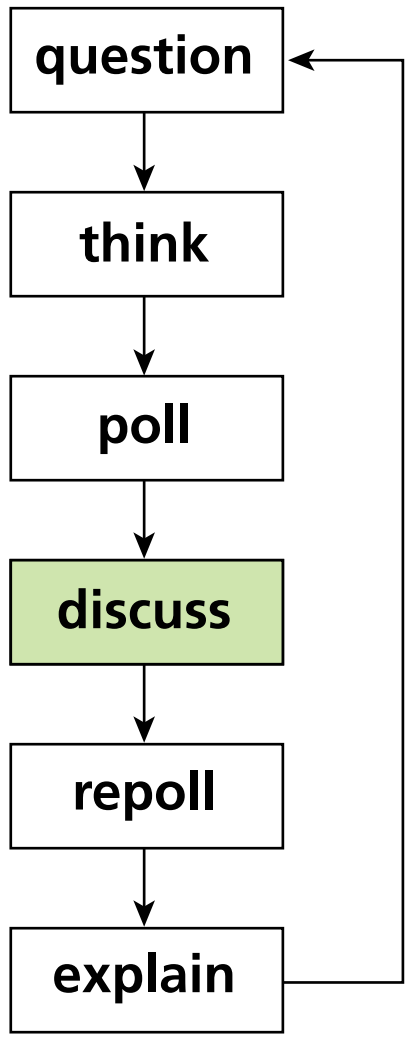

1 education

2 PI

Peer

is it any good?

INSTRUCTION

1 education

2 PI

3 results

first year of implementing PI

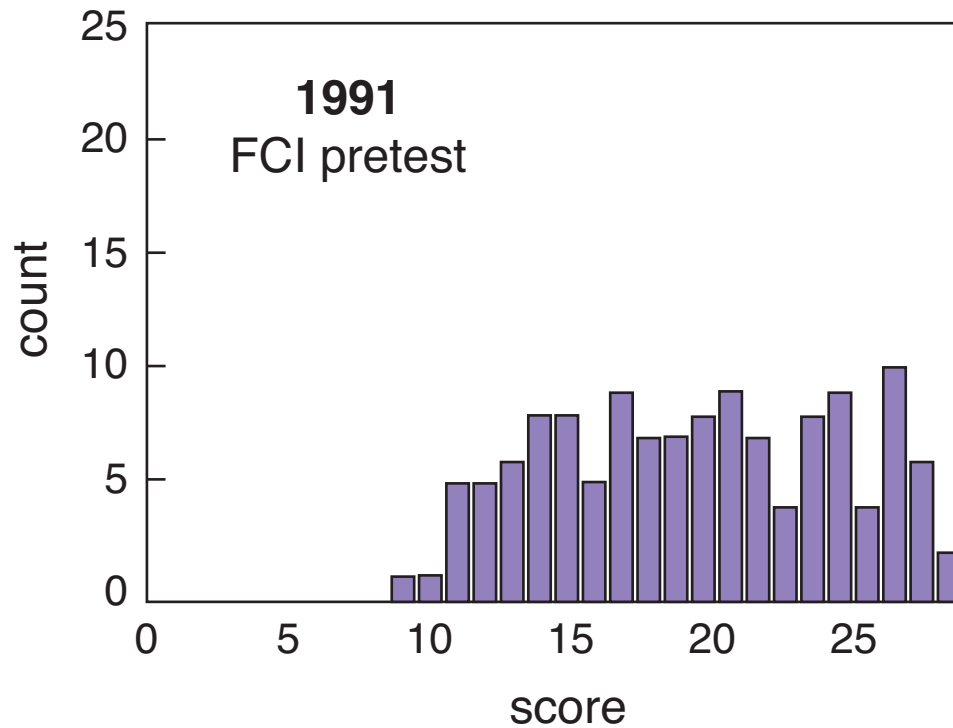

1 education

2 PI

3 results

first year of implementing PI

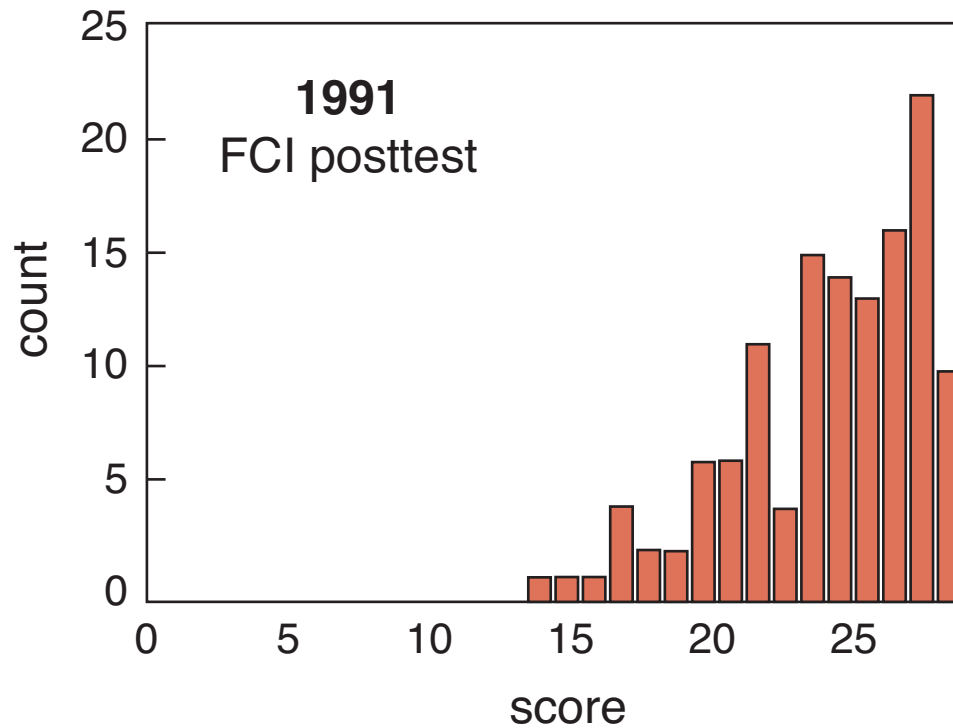

1 education

2 PI

3 results

first year of implementing PI

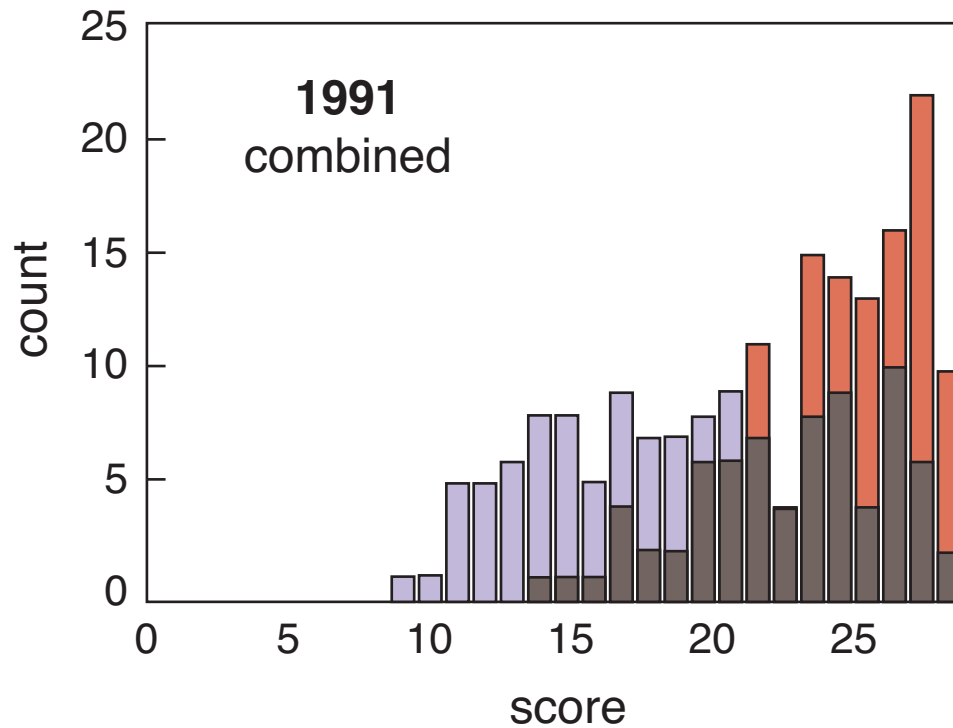

1 education

2 PI

3 results

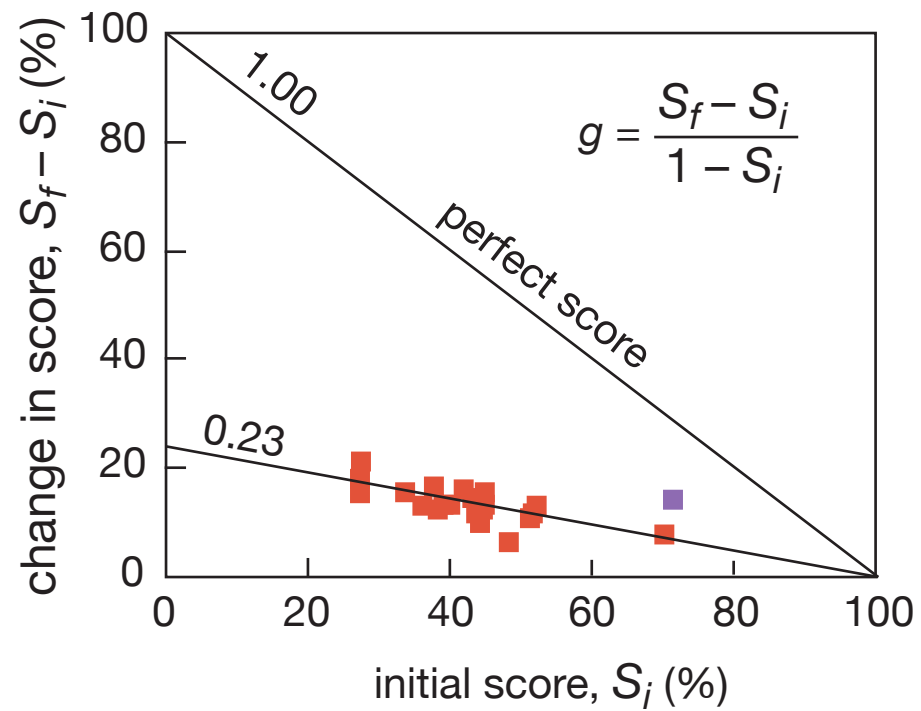

1 education

2 PI

3 results

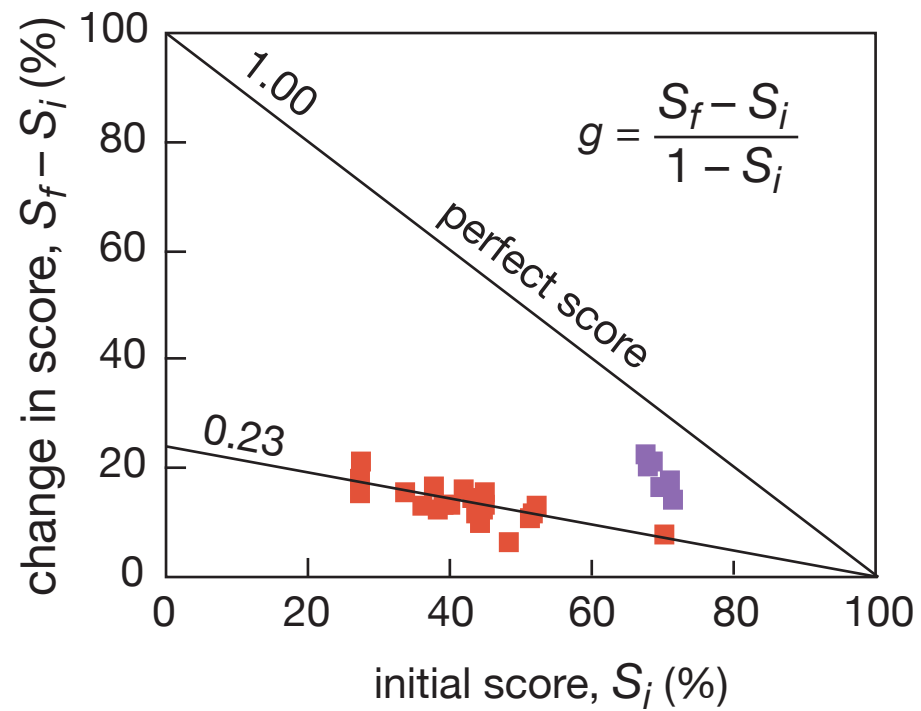

1 education

2 PI

3 results

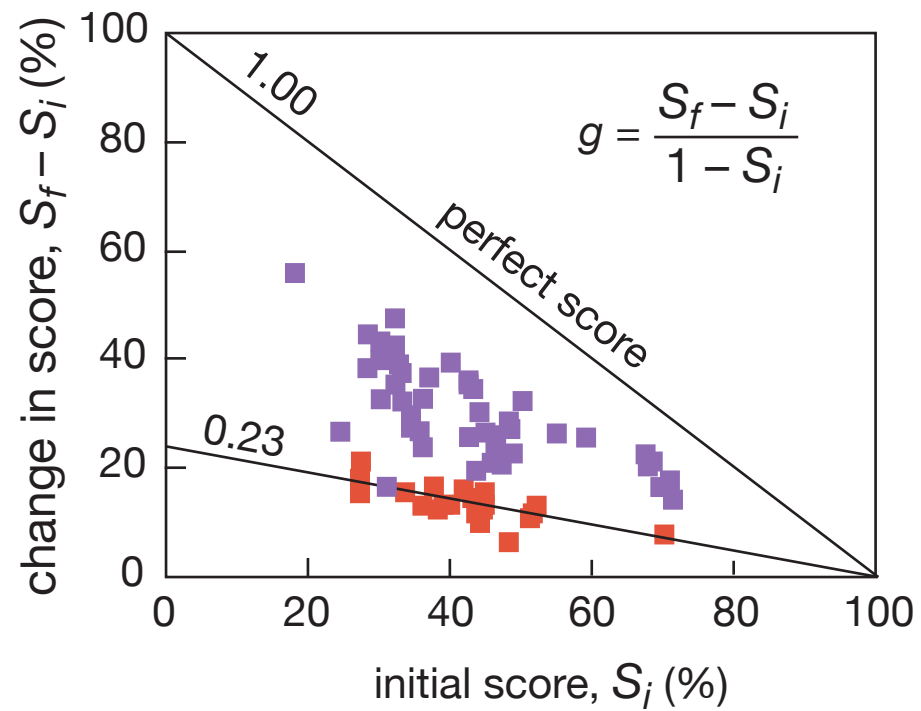

R.R. Hake, *Am. J. Phys.* 66, 64 (1998)

1 education

2 PI

3 results

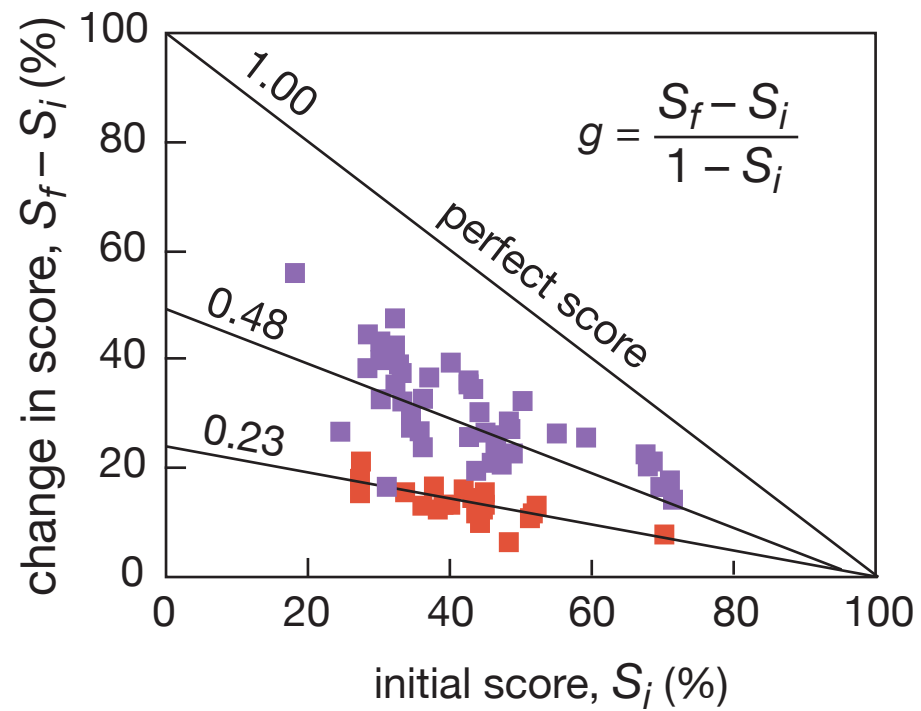

R.R. Hake, *Am. J. Phys.* 66, 64 (1998)

1 education

2 PI

3 results



Peer

what about problem solving?



INSTRUCTION

1 education

2 PI

3 results

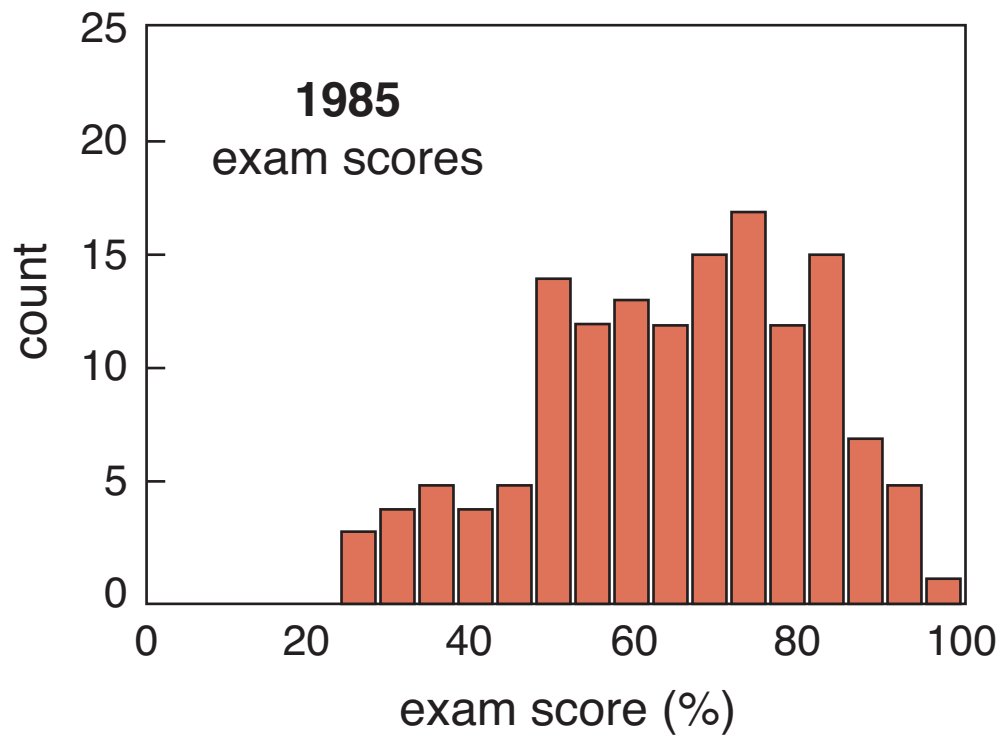

1 education

2 PI

3 results

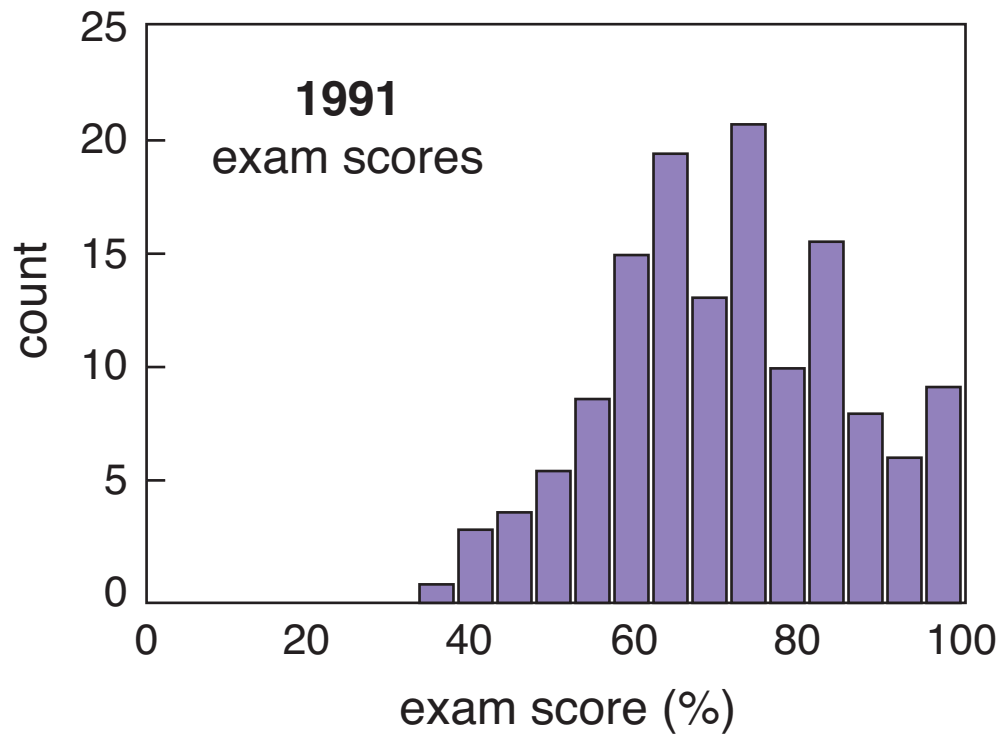

1 education

2 PI

3 results

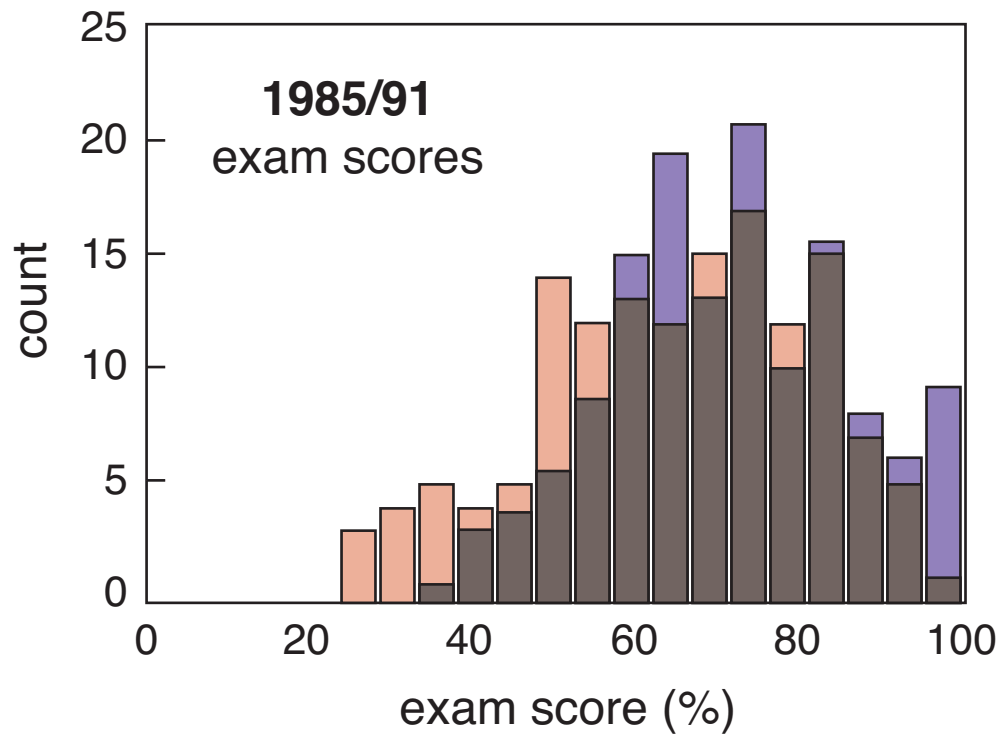

1 education

2 PI

3 results



**So better understanding leads to better
problem solving!**

INSTRUCTION

1 education

2 PI

3 results

So better understanding leads to better problem solving!

(but “good” problem solving doesn’t always indicate understanding!)

INSTRUCTION

1 education

2 PI

3 results



1 education

2 PI

3 results

in a lecture, students...

1 education

2 PI

3 results

in a lecture, students...

1. don't pay utmost attention

1 education

2 PI

3 results

in a lecture

1. don't pay utmost

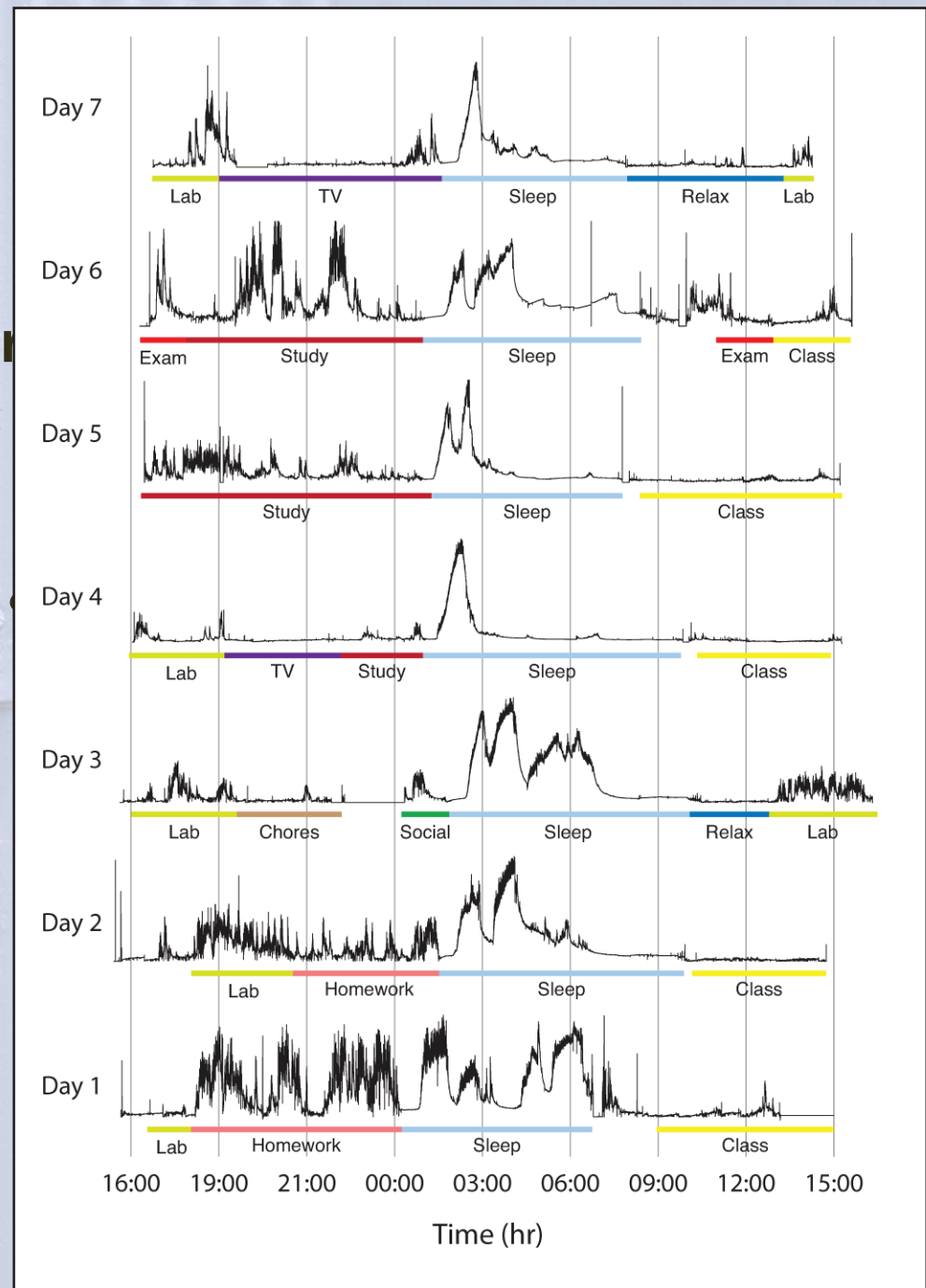

doi: 10.1109/TBME.2009.2038487

1 education

2 PI

3 results

in a lecture

1. don't pay utmost

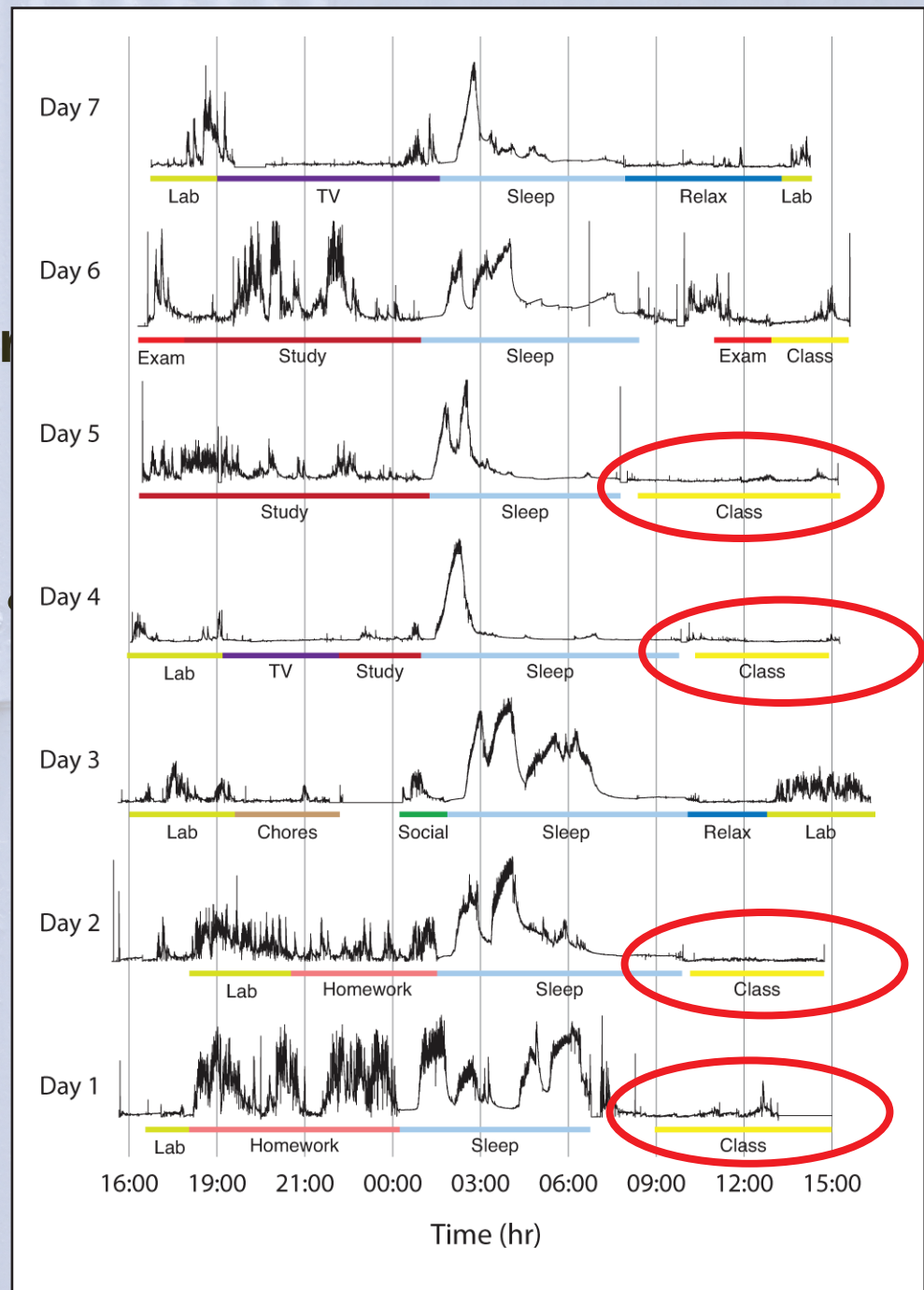

doi: 10.1109/TBME.2009.2038487

1 education

2 PI

3 results

in a lecture

1. don't pay utmost

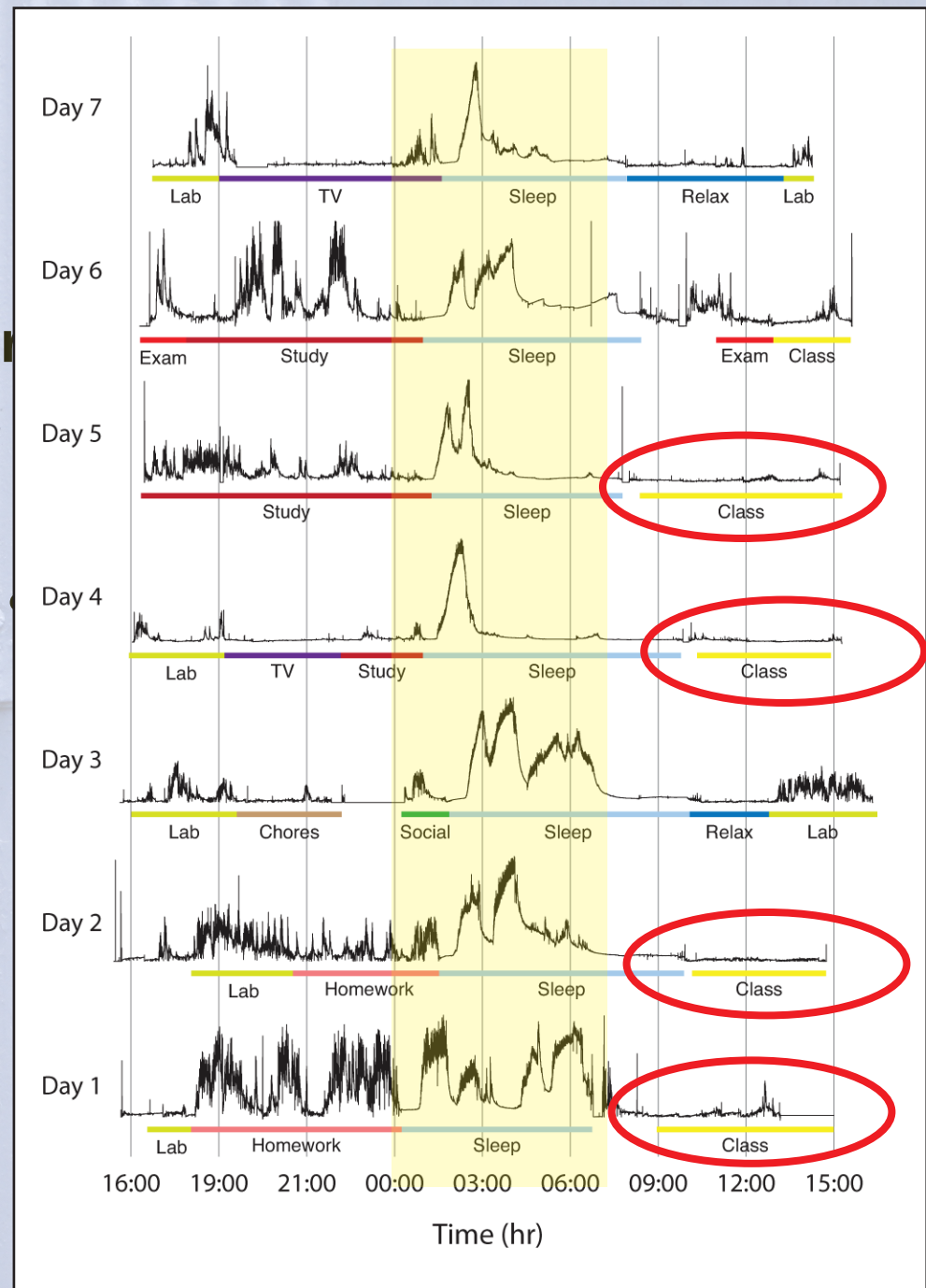

doi: 10.1109/TBME.2009.2038487

1 education

2 PI

3 results

in a lecture

1. don't pay utmost

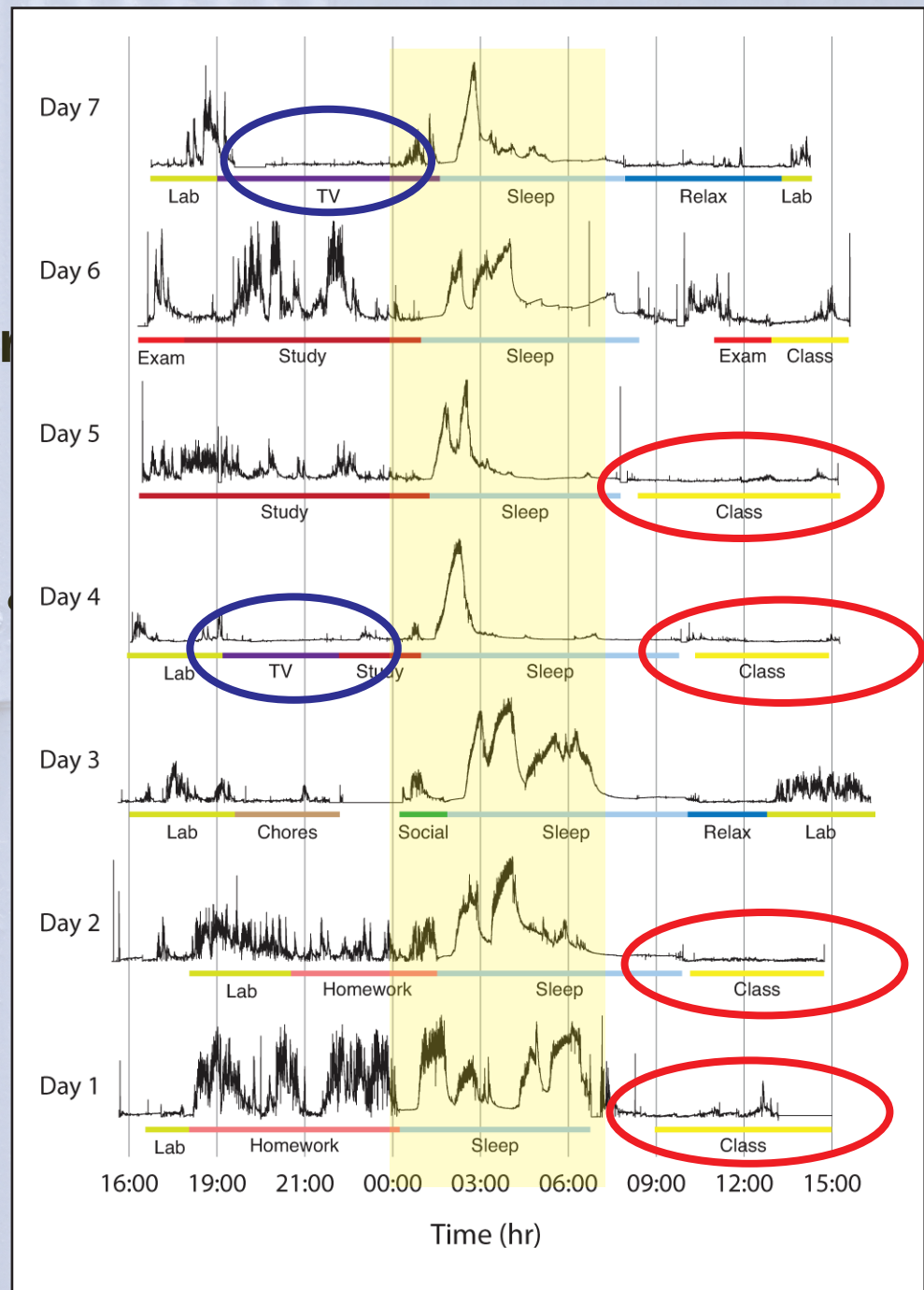

doi: 10.1109/TBME.2009.2038487

1 education

2 PI

3 results

in a lecture, students...

1. don't pay utmost attention

2. think they know it

in a lecture, students...

- 1. don't pay utmost attention**
- 2. think they know it**
- 3. are not confronted with misconceptions**

in a lecture, students...

1. don't pay utmost attention

2. think they know it

3. are not confronted with misconceptions

false
sense of security



1 education

2 PI

3 results



an illusion. . .

1 education

2 PI

3 results



Education is not just about:

- **transferring information**
- **getting students to do what we do**

1 education

2 PI

3 results



Education is not just about:

- **transferring information**
- **getting students to do what we do**

active participation a must!

1 education

2 PI

3 results



1 education

2 PI

3 results



三人行，必有我师焉。

——孔子

1 education

2 PI

3 results

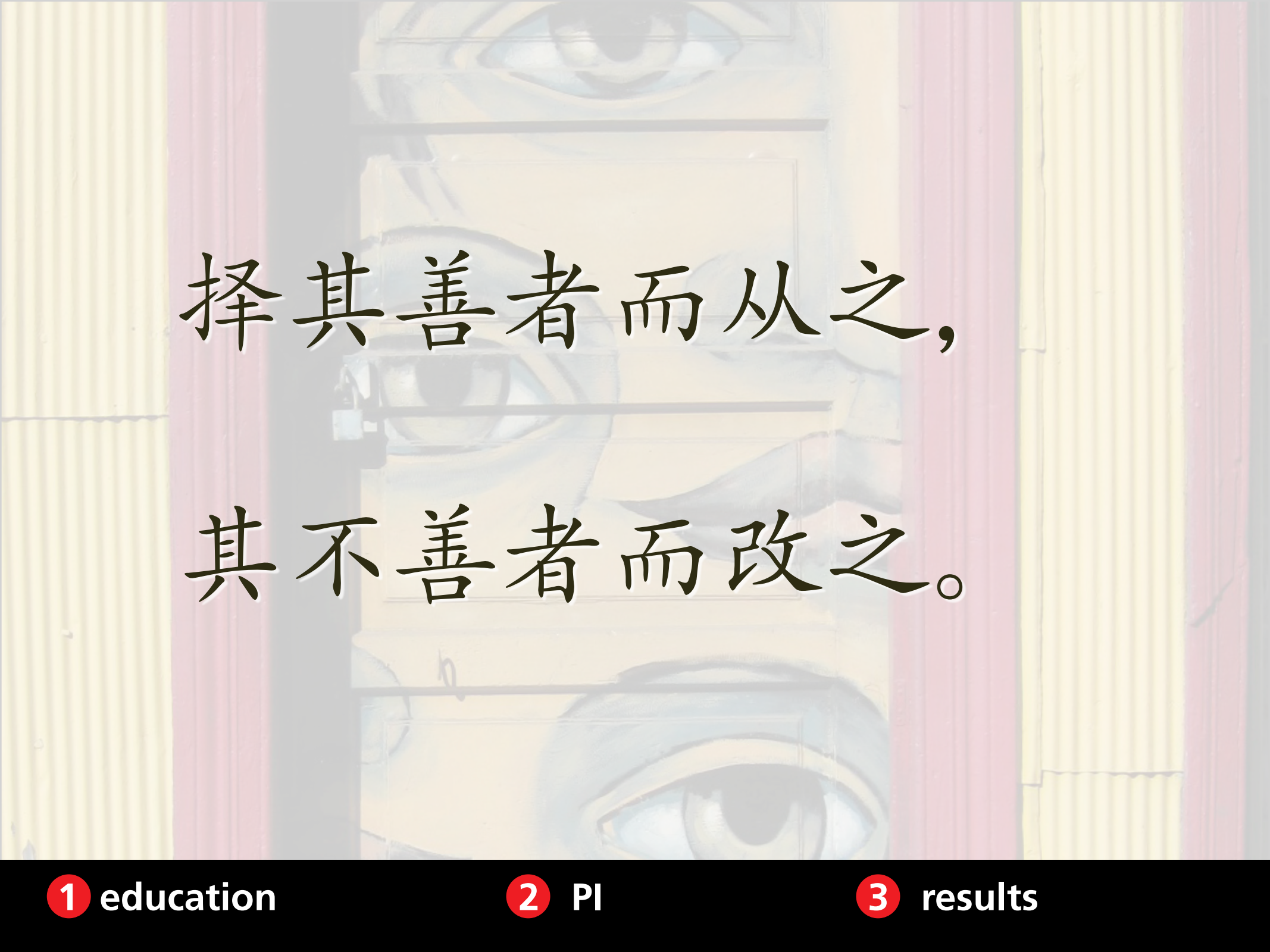

择其善者而从之，
其不善者而改之。

Funding:

National Science Foundation

for a copy of this presentation:

mazur.harvard.edu

Follow me!



eric_mazur

Google™

Google Search

I'm Feeling Lucky

Google™

mazur

Google Search

I'm Feeling Lucky

Google™

Google Search

I'm Feeling Lucky

Google™

Google Search

I'm Feeling Lucky

A row of wooden beads on a string, with a red and white background. The beads are arranged in a slightly curved line, and the background is split into a red vertical strip on the left and a white area on the right.

First International Asia-Pacific Conference on Peer Instruction

Beijing, China

mazur@harvard.edu

14-16 December 2012



Join now!

PeerInstruction.net