



ULTRAFAST LASER-INDUCED PHASE TRANSITIONS IN SEMICONDUCTORS

Eli Glezer

Li Huang

Paul Callan

Yakir Siegal

Boston College

18 September 1996

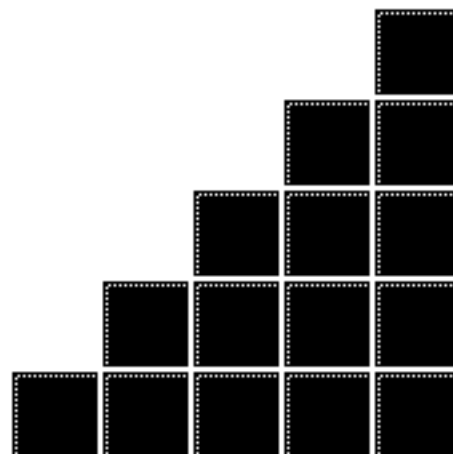

INTRODUCTION

- 1976: (nanosecond) laser annealing of crystals damaged by ion bombardment
- 1985: femtosecond laser 'melting' of Si



INTRODUCTION

laser deposits energy near surface...

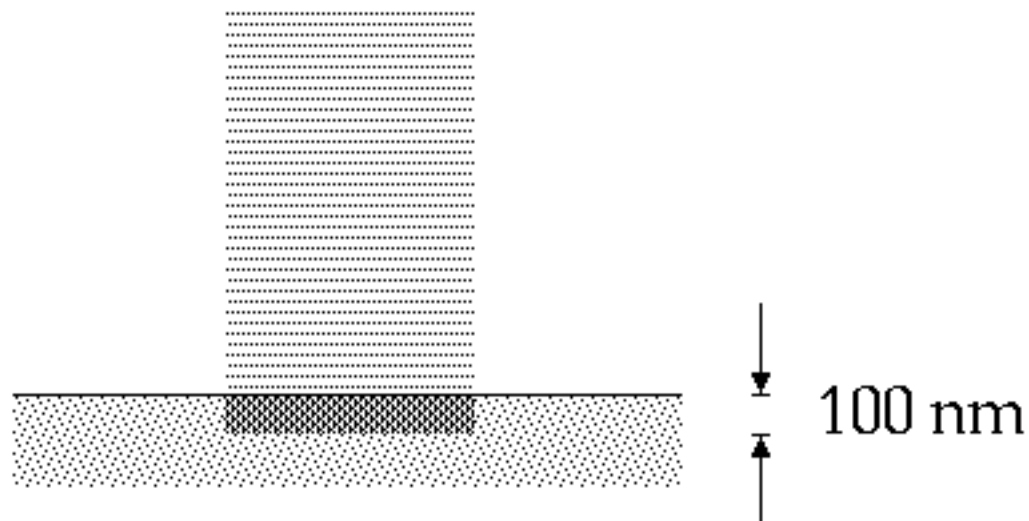

INTRODUCTION

energy rapidly diffuses into bulk...

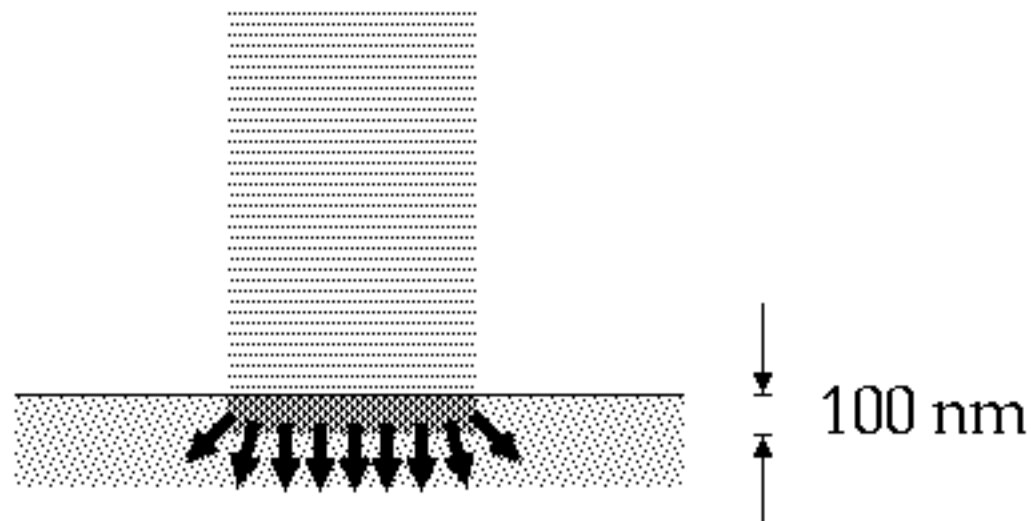

in 1 ns, diffusion length ≈ 100 nm



INTRODUCTION

For $t < 1$ ns can ignore diffusion

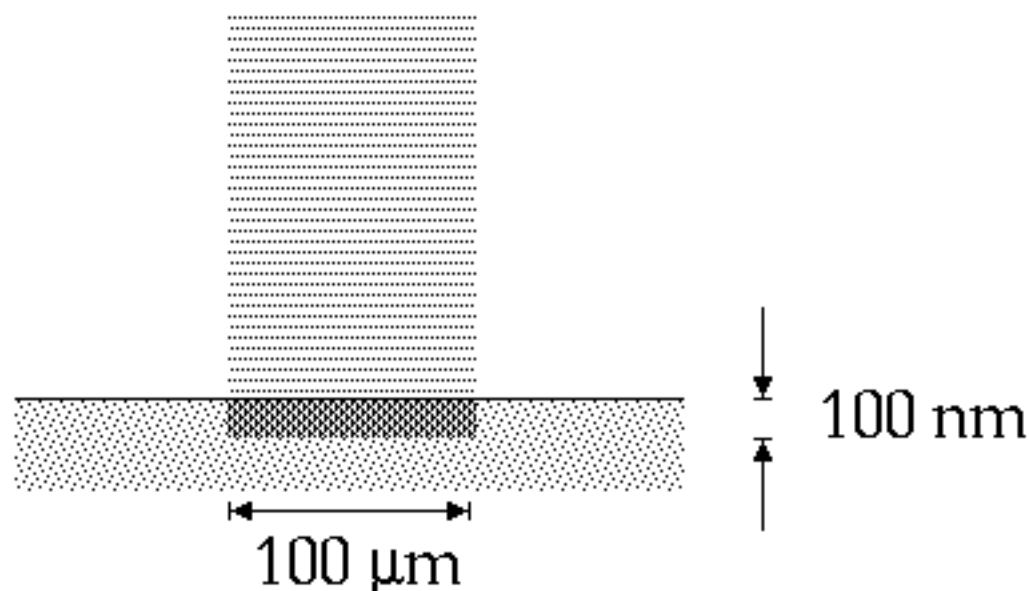

10 μJ into a volume of about 10^{-15} m³!



- ① Background
- ② Single frequency work
- ③ Broadband work



EARLY MODELS

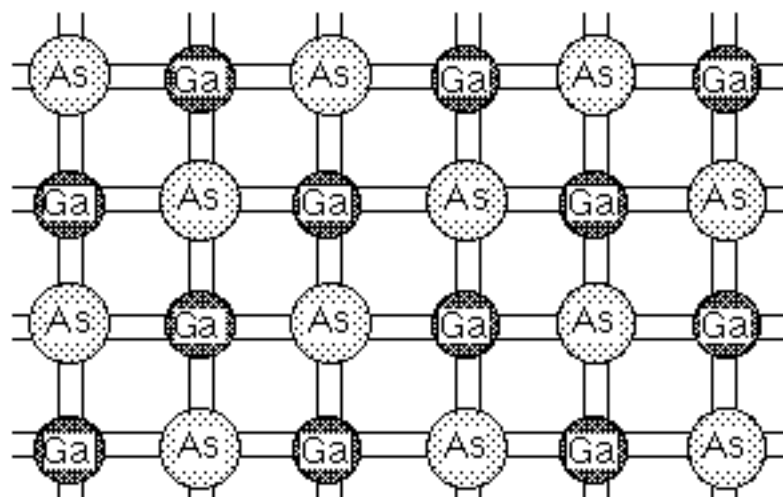

how does light melt a solid?



THERMAL MODEL

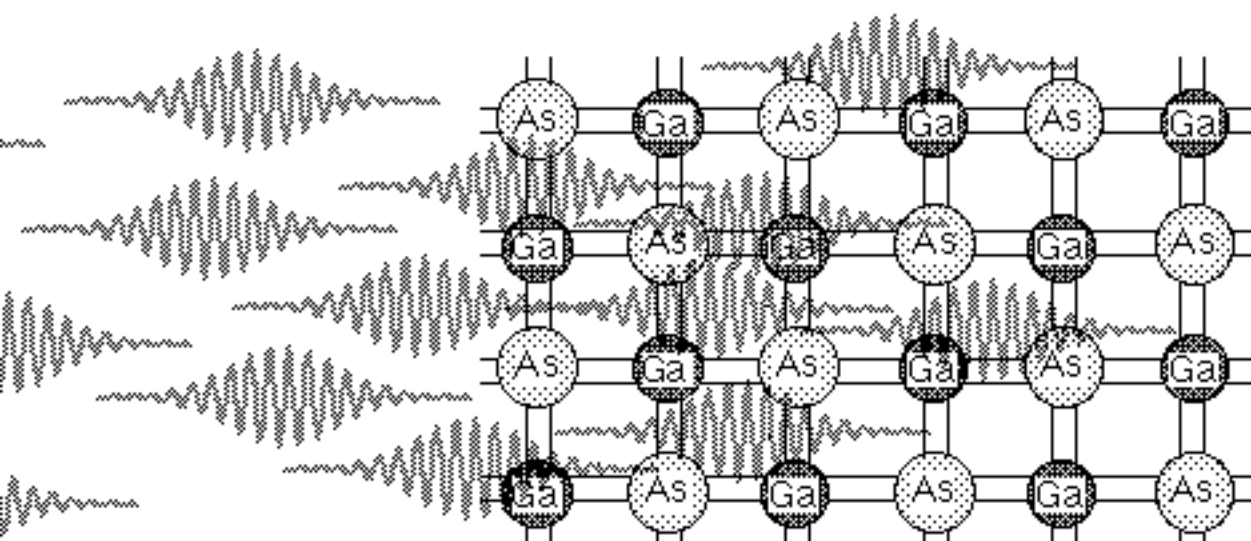

photons excite valence electrons...



THERMAL MODEL

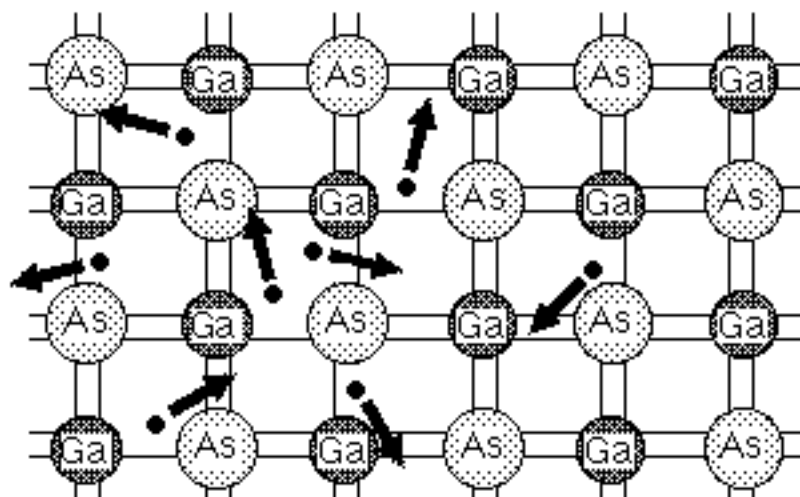

...and create hot electrons...



THERMAL MODEL

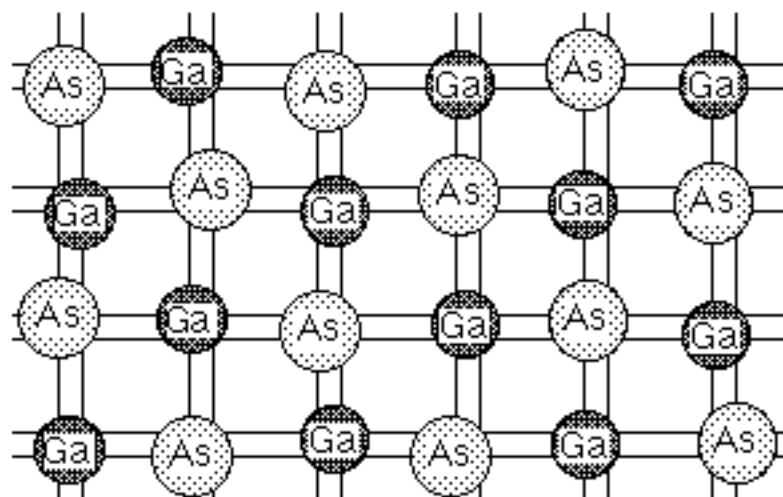

...which heat lattice



THERMAL MODEL

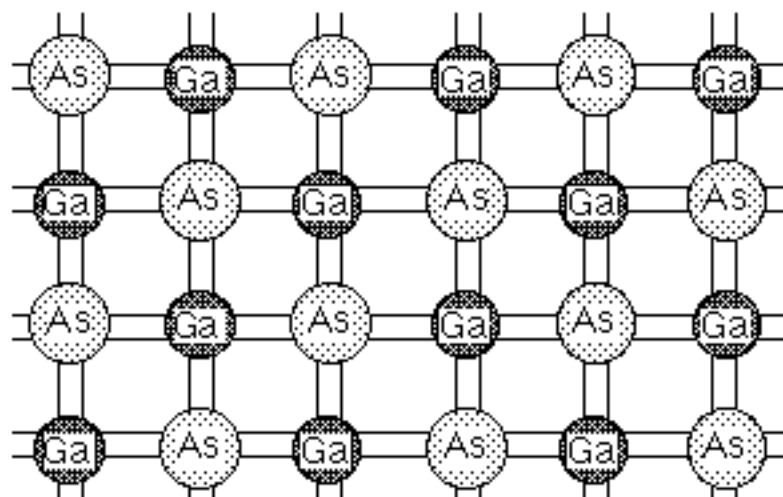

...which heat lattice



THERMAL MODEL

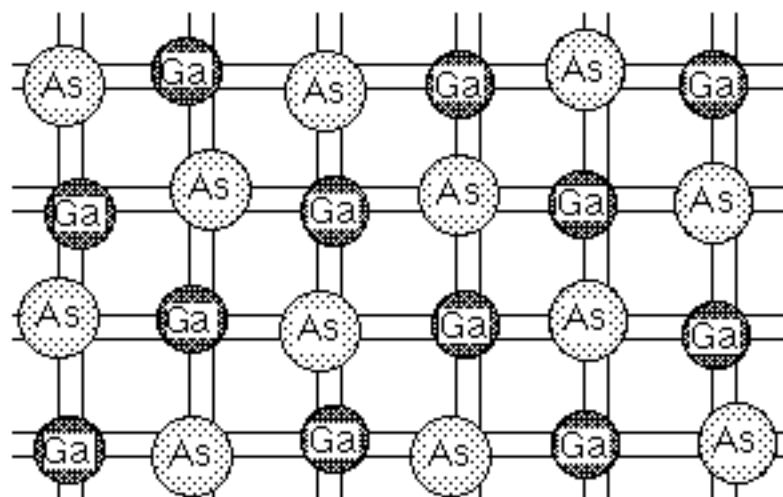

...which heat lattice



EARLY MODELS

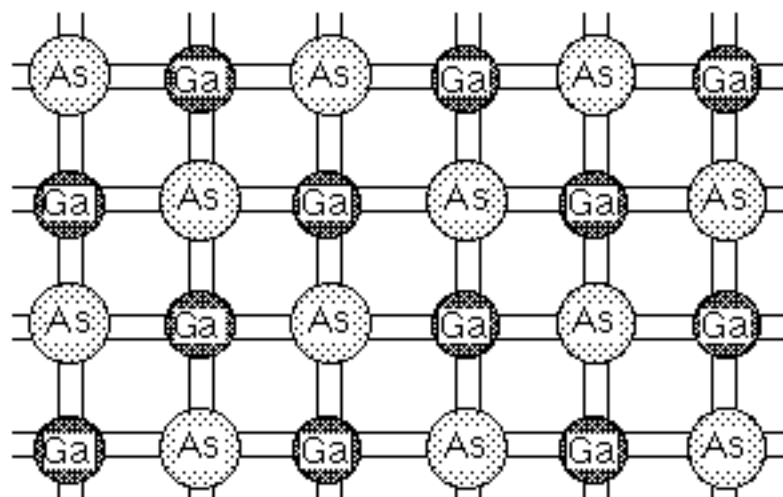

...or...



PLASMA ANNEALING

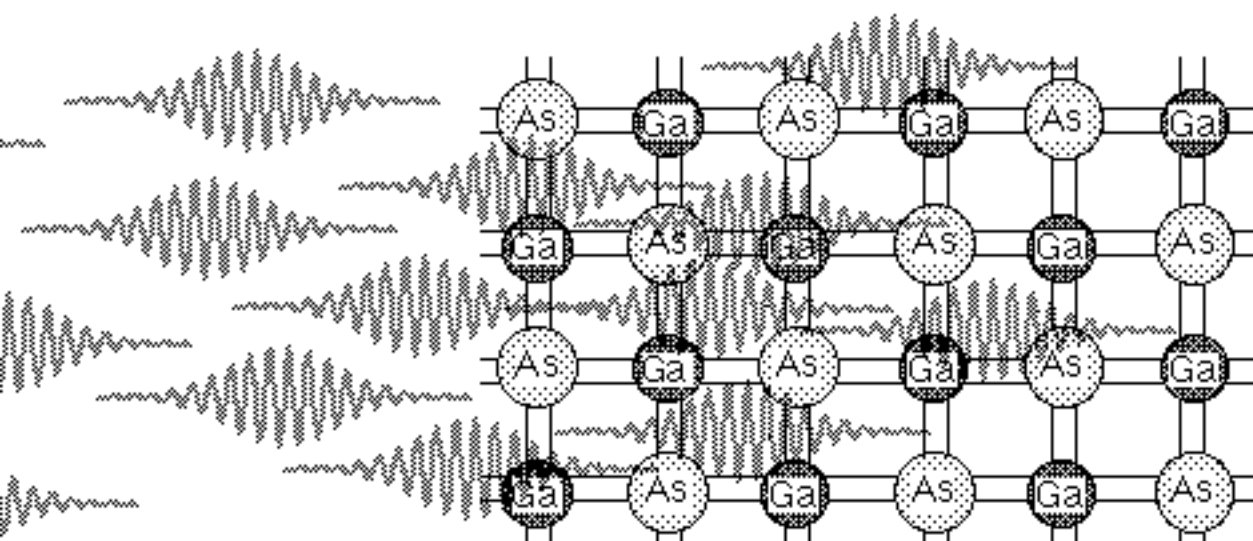

photons excite valence electrons...



PLASMA ANNEALING

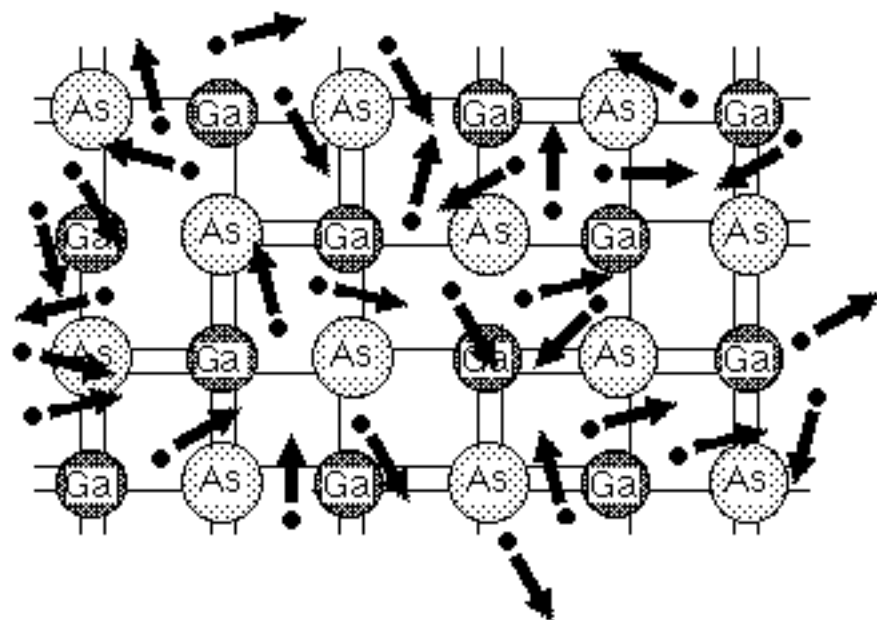

...creating a dense plasma...



PLASMA ANNEALING

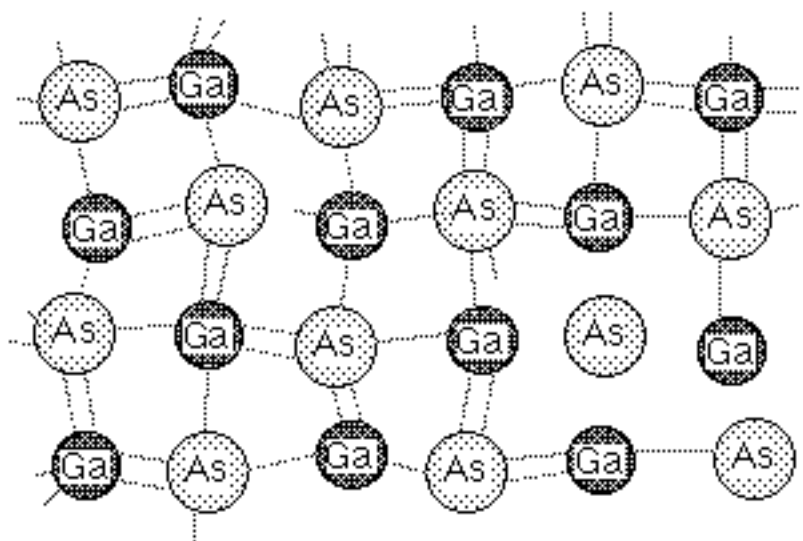

...and breaking bonds



EXCITATION

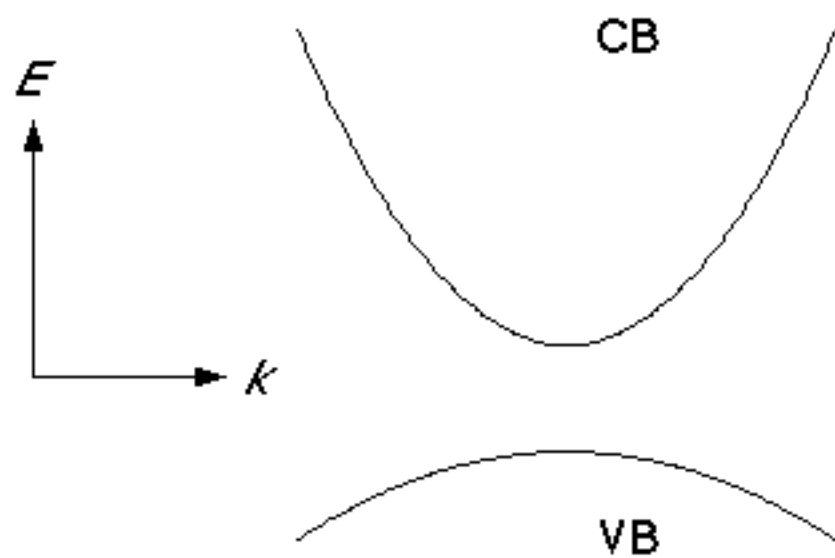

EXCITATION

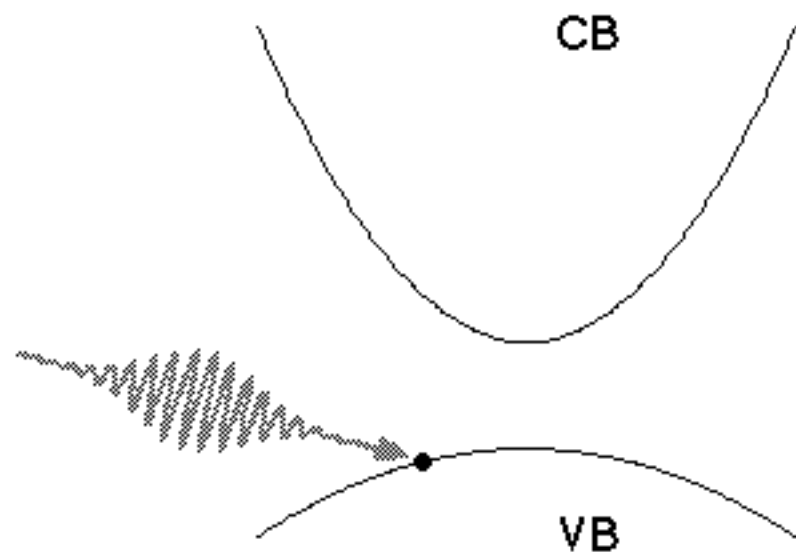

photon excites valence electron



EXCITATION

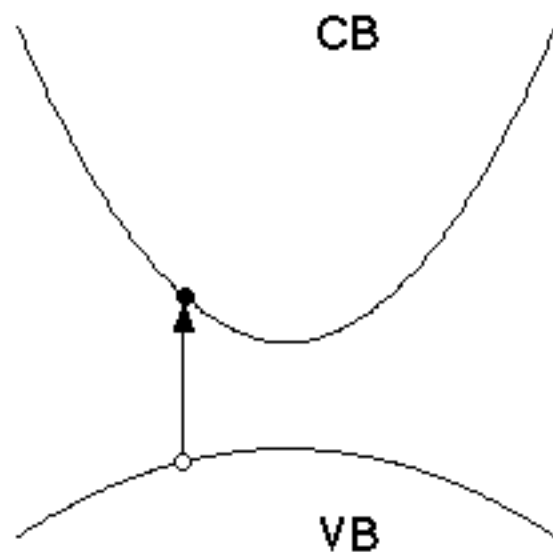

creating an electron-hole pair



EXCITATION

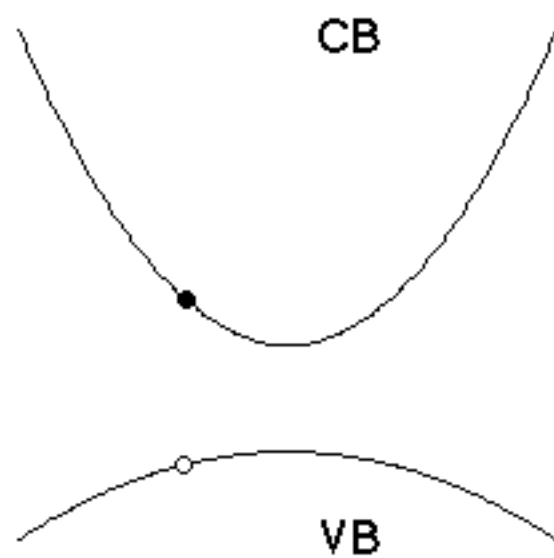

EXCITATION

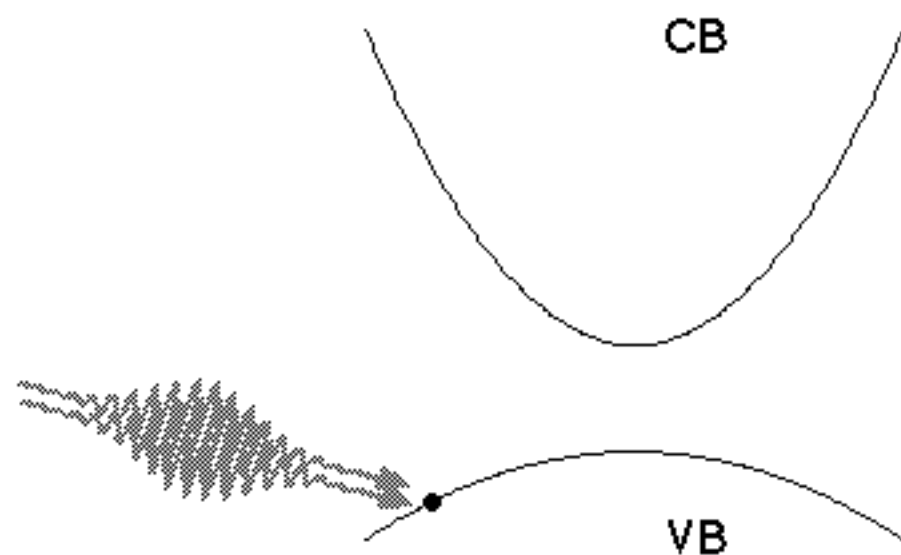

multiphoton excitation



EXCITATION

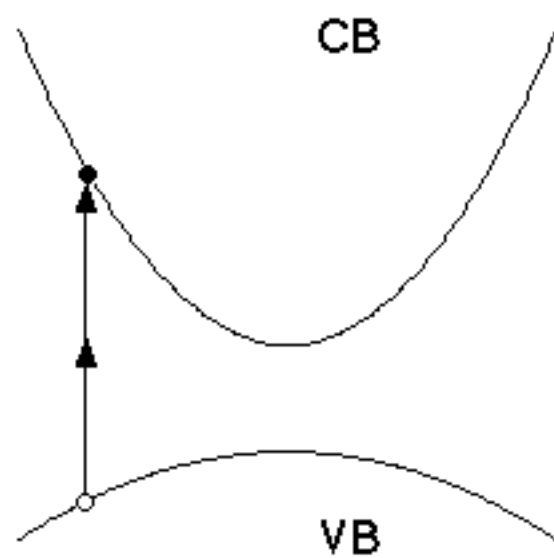

EXCITATION

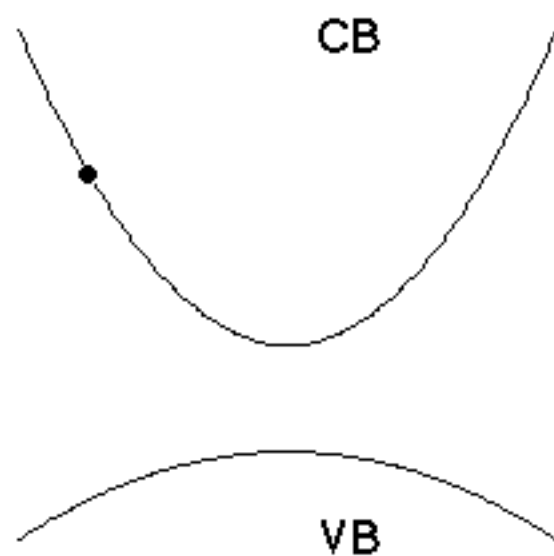

RELAXATION

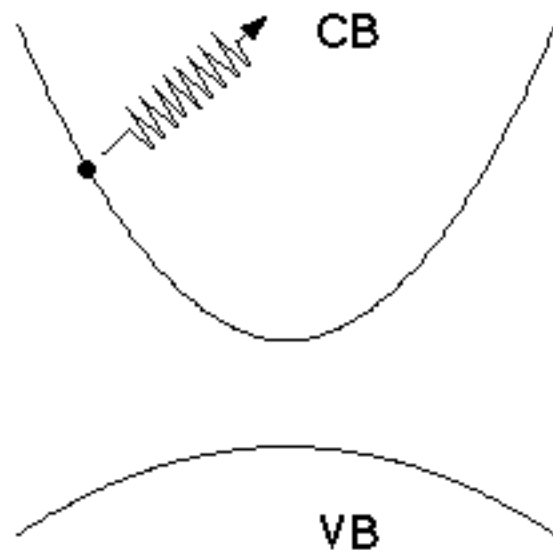

emission of LO phonons



RELAXATION

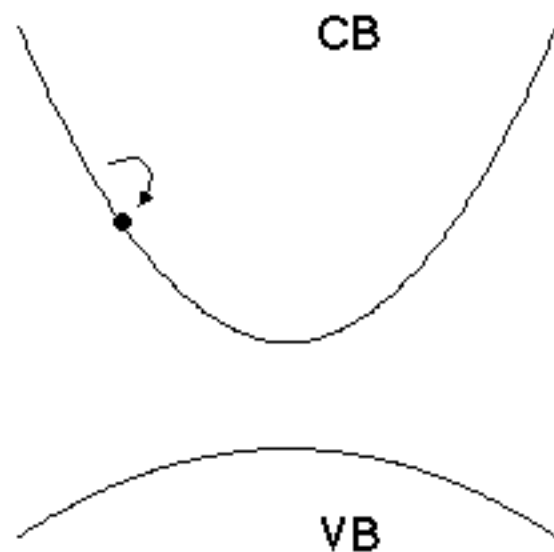

emission of LO phonons



RELAXATION

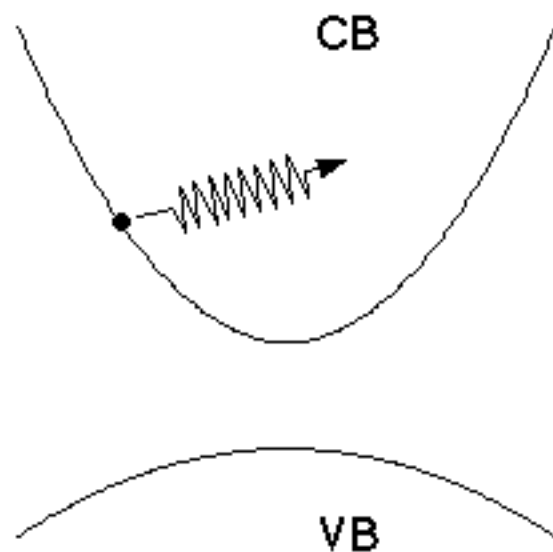

emission of LO phonons



RELAXATION

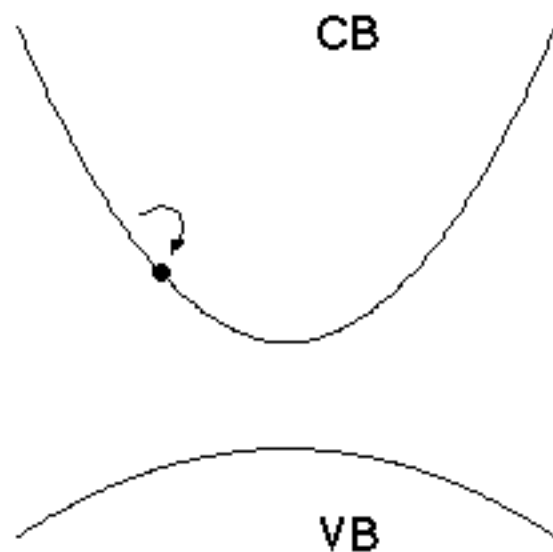

emission of LO phonons



RELAXATION

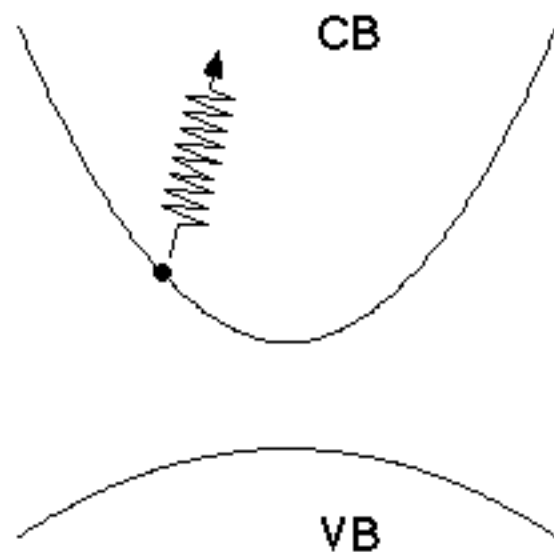

emission of LO phonons



RELAXATION

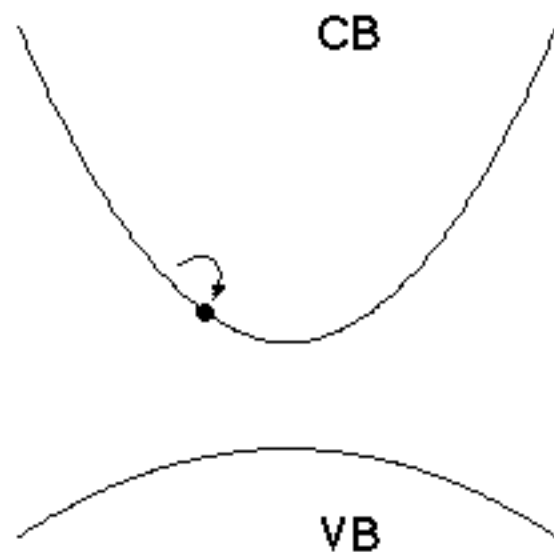

emission of LO phonons



RELAXATION

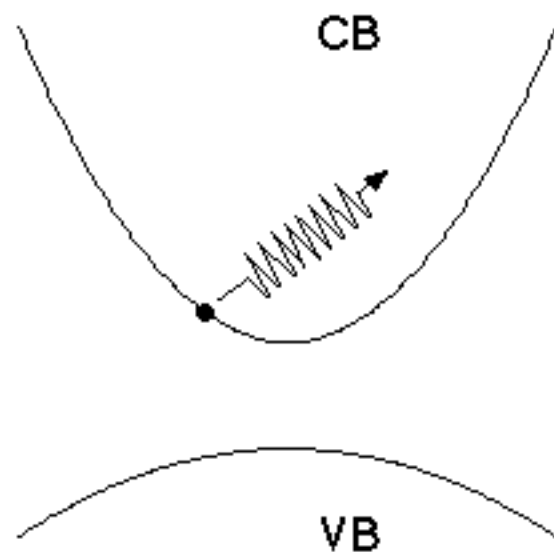

emission of LO phonons



RELAXATION

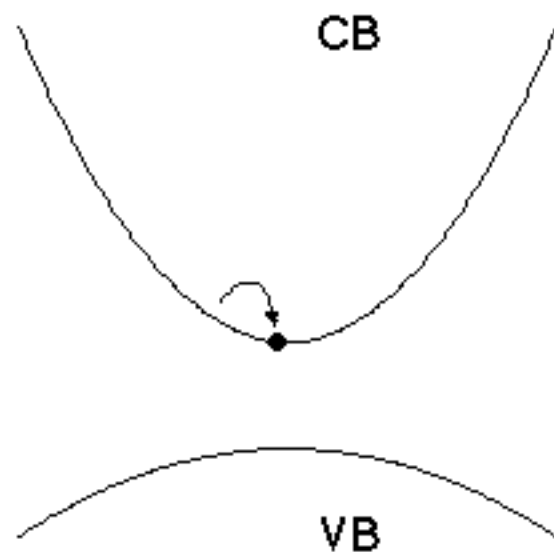

emission of LO phonons



RELAXATION

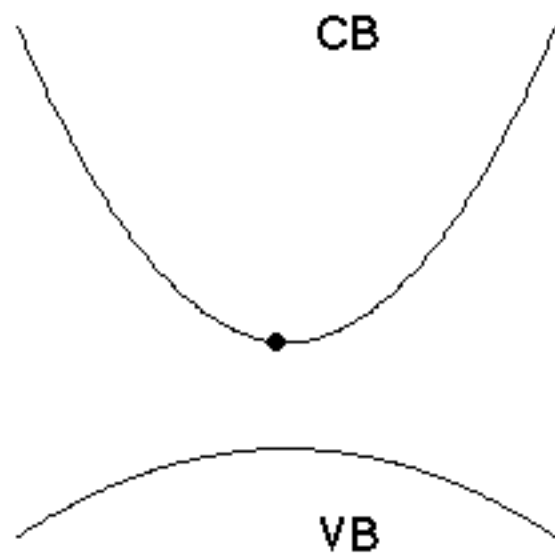

TIME SCALE

long pulses ($\tau_{exc} \gg 1$ ps): *thermal melting*

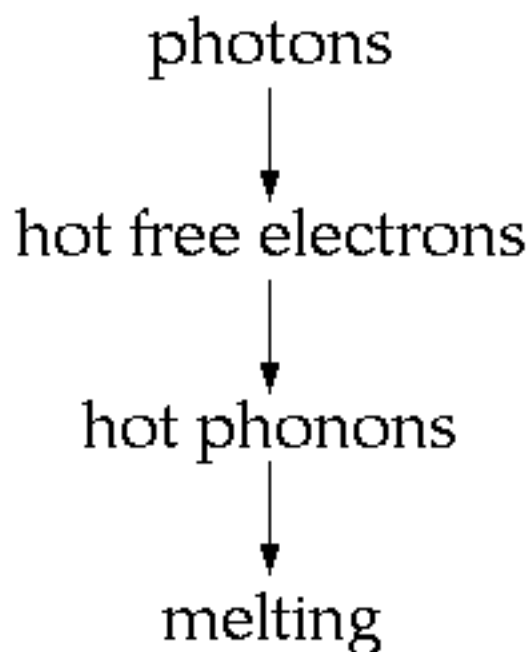

TIME SCALE

short pulses ($\tau_{exc} \ll 1$ ps): *nonthermal disordering*

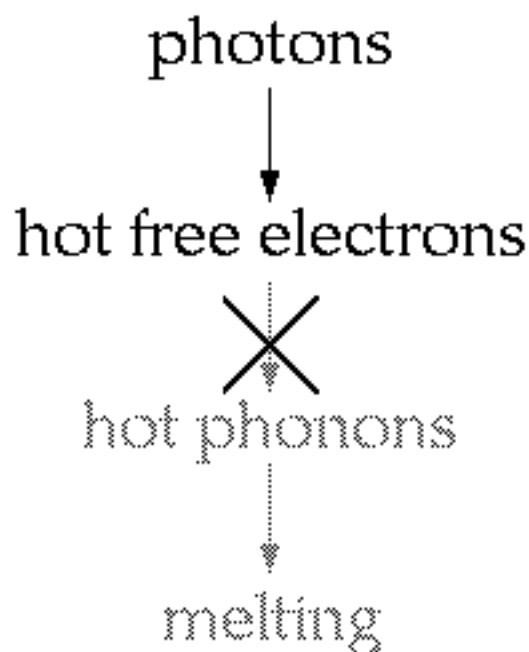

- ① Background
- ② Single frequency work
- ③ Broadband work



FEMTOSECOND WORK

Phonons

How can we drive them?

Beyond phonons

What happens when we break
the limit?



EXCITATION OF PHONONS

<i>absorption</i>	incoherent heating	$\tau_{e-ph} \approx 2 \text{ ps} \gg T_{ph}$
<i>SRS, CARS</i>	coherent driving	$\tau_{exc} \geq 6 \text{ ps} \gg T_{ph}$
<i>ISRS</i>	impulsive excitation	$\tau_{exc} \approx 0.1 \text{ ps} \leq T_{ph}$



IMPULSIVE RAMAN SCATTERING



IMPULSIVE RAMAN SCATTERING

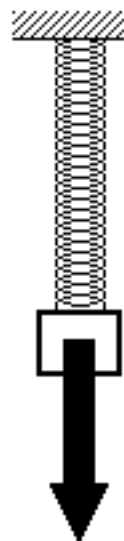

IMPULSIVE RAMAN SCATTERING



IMPULSIVE RAMAN SCATTERING

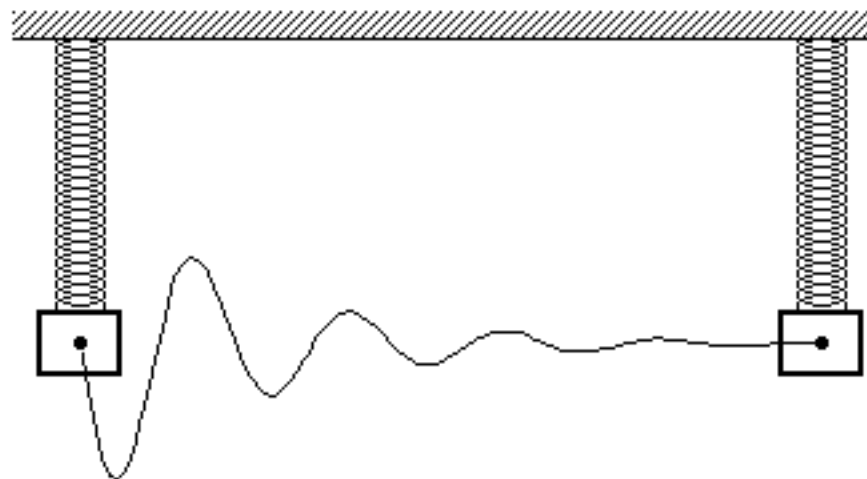

IMPULSIVE RAMAN SCATTERING

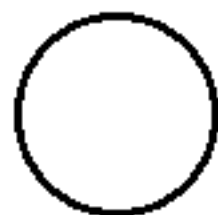

IMPULSIVE RAMAN SCATTERING

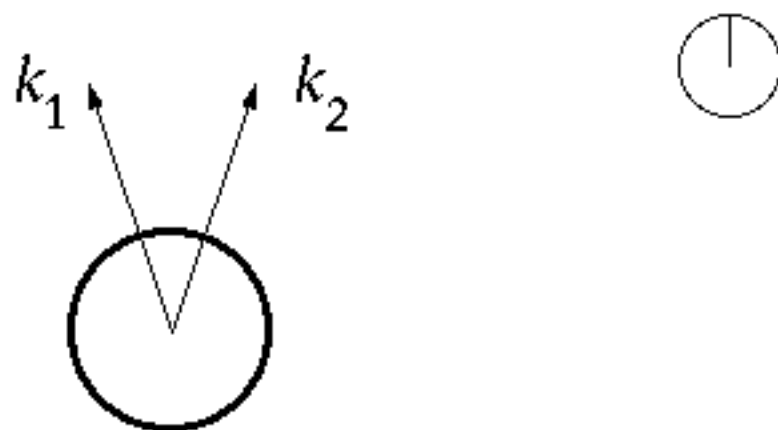

IMPULSIVE RAMAN SCATTERING

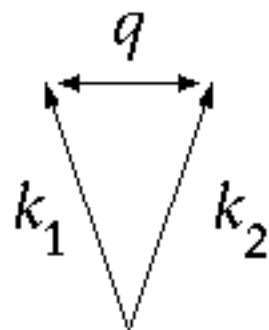
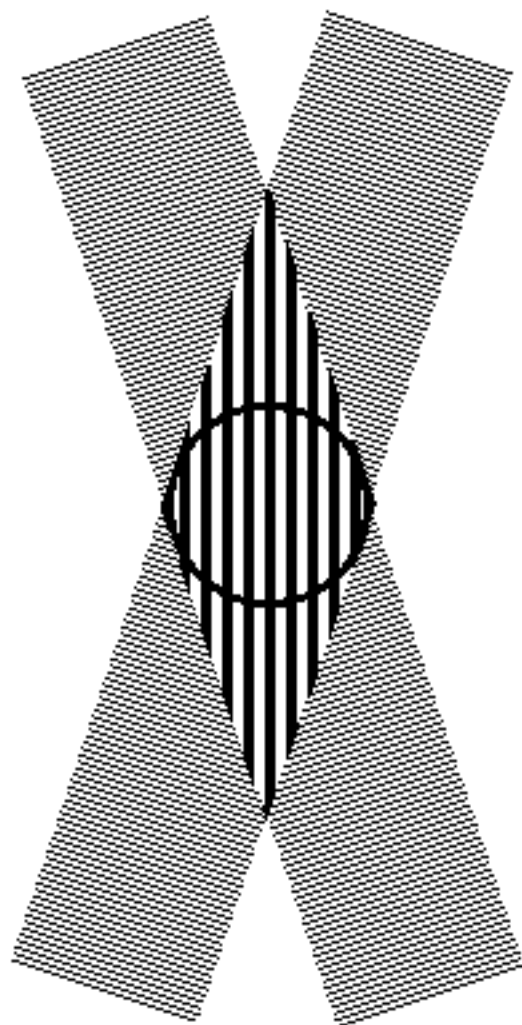

$$k_1 - k_2 = \pm q$$



IMPULSIVE RAMAN SCATTERING



create decaying standing wave...



IMPULSIVE RAMAN SCATTERING



create decaying standing wave...



IMPULSIVE RAMAN SCATTERING



create decaying standing wave...



IMPULSIVE RAMAN SCATTERING



create decaying standing wave...



IMPULSIVE RAMAN SCATTERING



create decaying standing wave...



IMPULSIVE RAMAN SCATTERING



create decaying standing wave...



IMPULSIVE RAMAN SCATTERING



create decaying standing wave...



IMPULSIVE RAMAN SCATTERING



create decaying standing wave...



IMPULSIVE RAMAN SCATTERING



create decaying standing wave...



IMPULSIVE RAMAN SCATTERING

A

 Δt

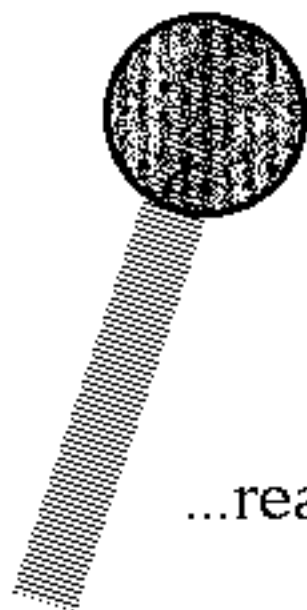

...read out with third beam



IMPULSIVE RAMAN SCATTERING

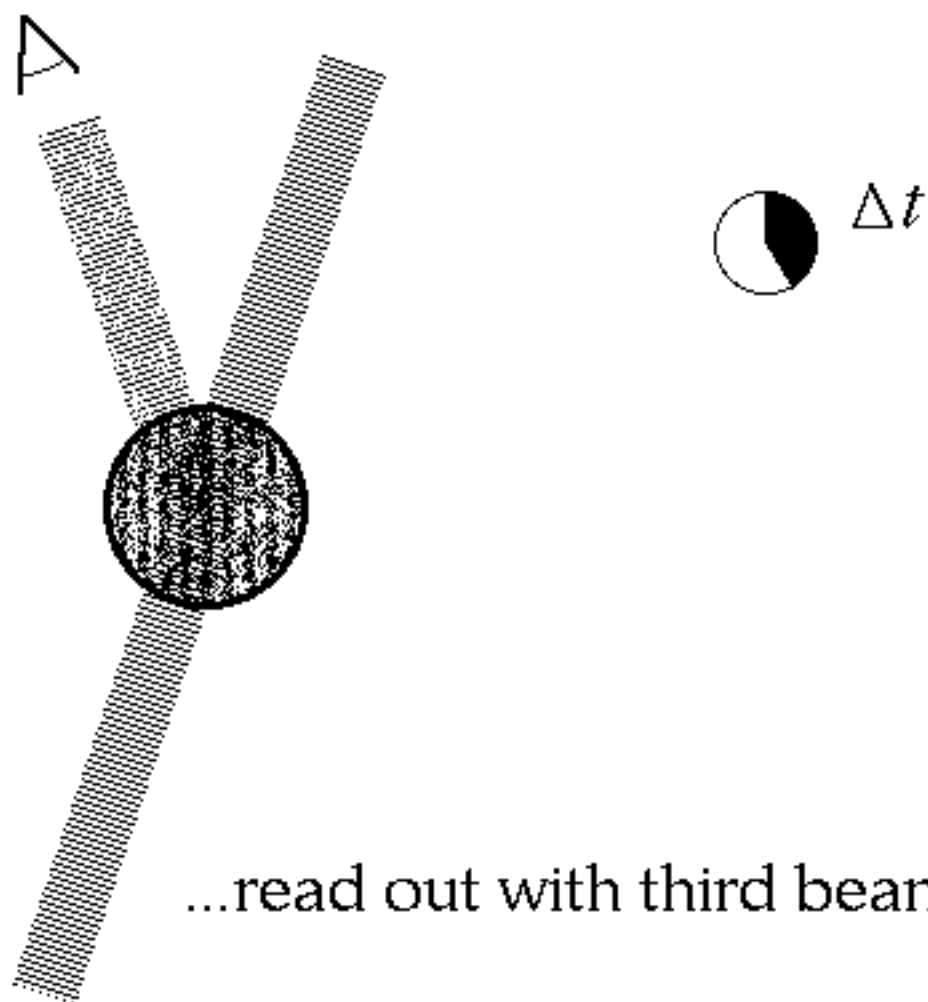

IMPULSIVE RAMAN SCATTERING

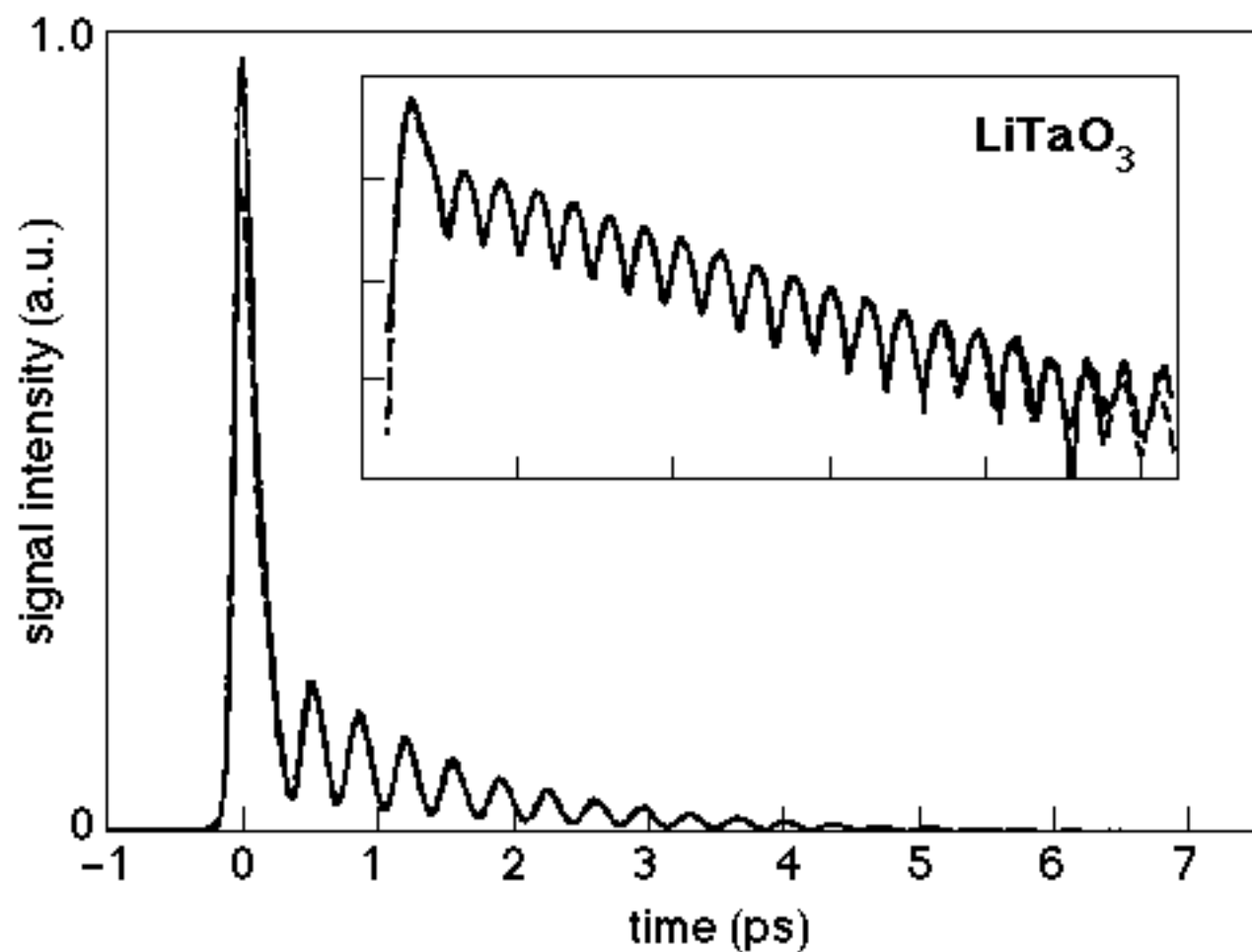

LARGE AMPLITUDE OSCILLATIONS

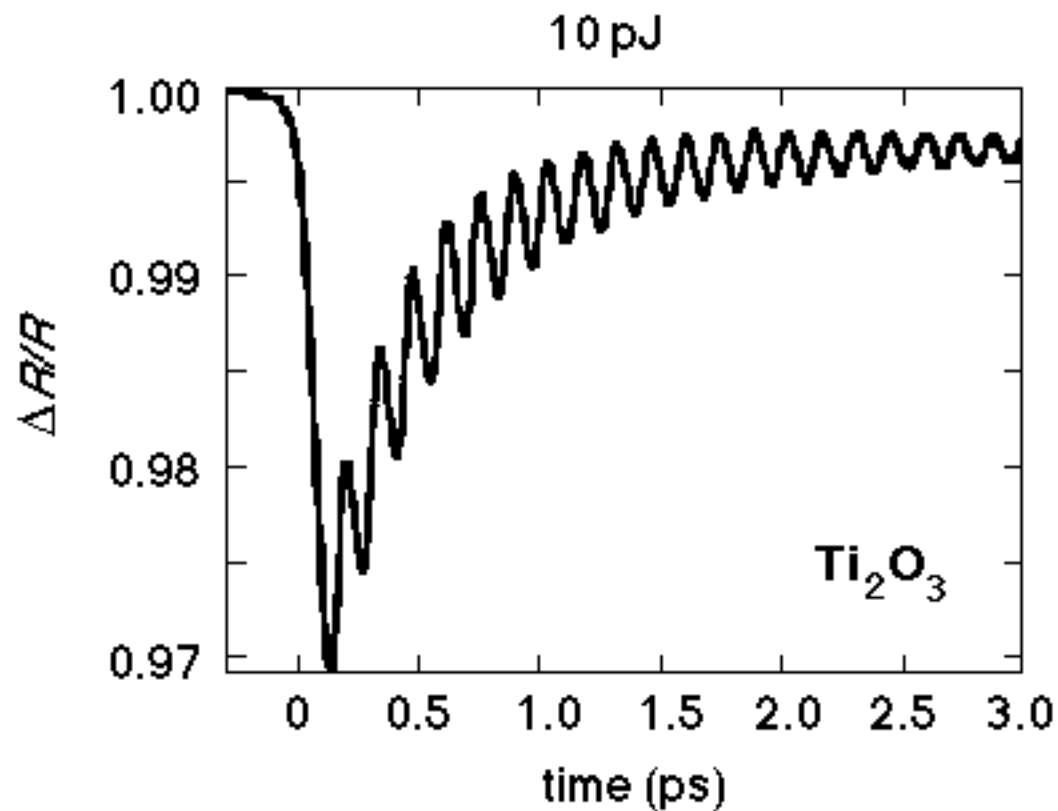

T.K. Cheng *et al.*, *Appl. Phys. Lett.* **57** (1990) 1004

H.J. Zeiger *et al.*, *Phys. Rev. B* **45** (1992) 768



LARGE AMPLITUDE OSCILLATIONS

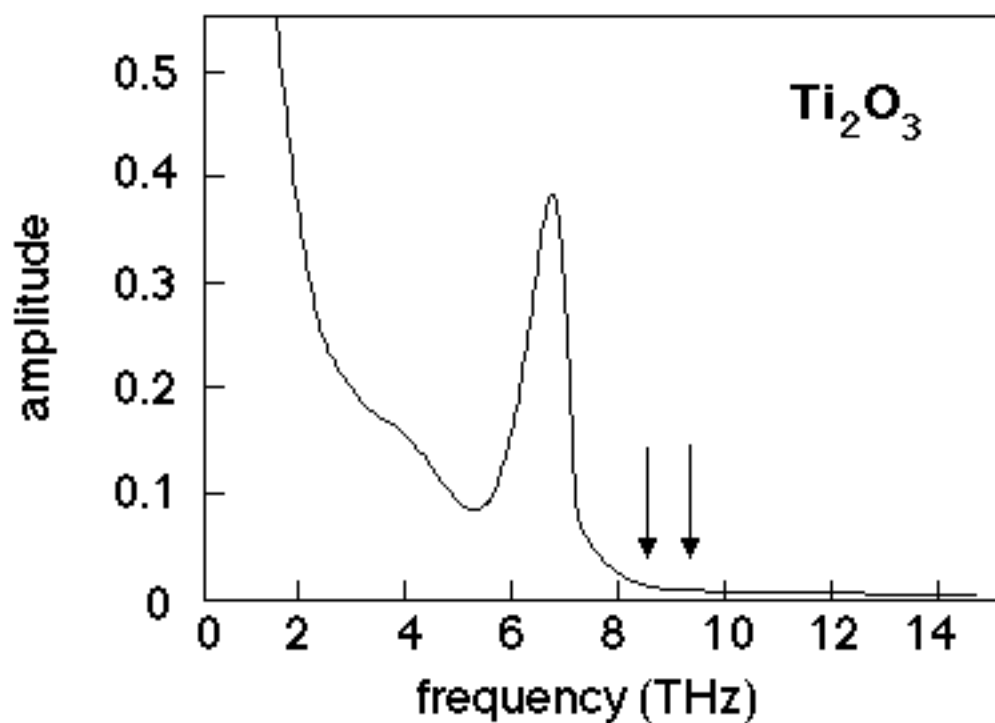

T.K. Cheng *et al.*, *Appl. Phys. Lett.* **57** (1990) 1004

H.J. Zeiger *et al.*, *Phys. Rev. B* **45** (1992) 768



IMPULSIVE RAMAN SCATTERING

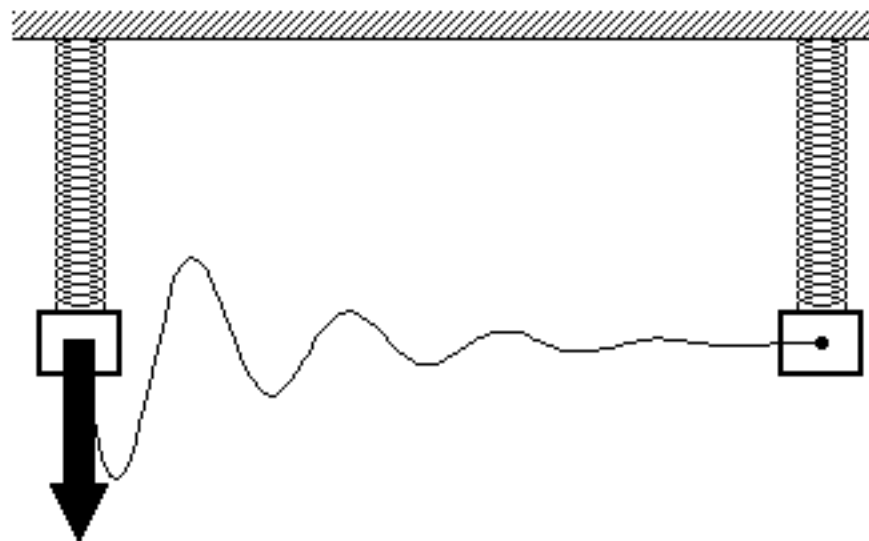

- need to match q
- sinusoidal oscillation



DISPLACIVE EXCITATION

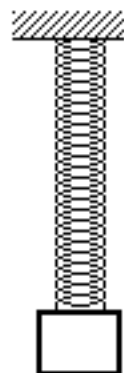

DISPLACIVE EXCITATION



DISPLACIVE EXCITATION

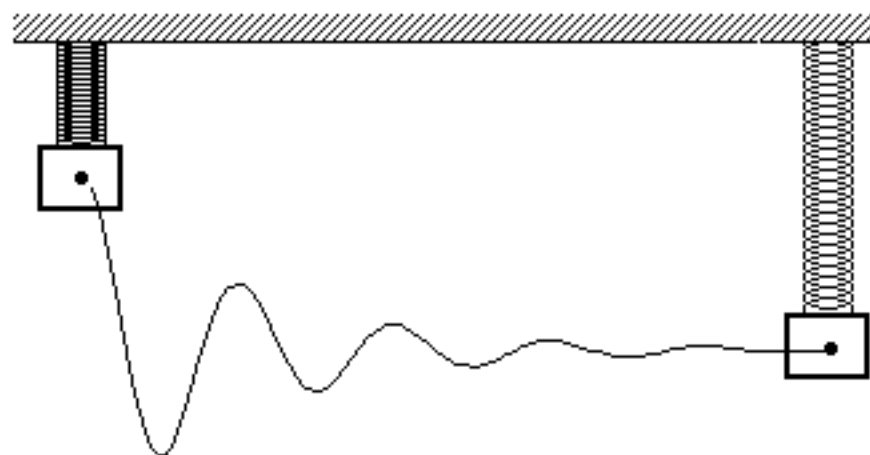

DISPLACIVE EXCITATION

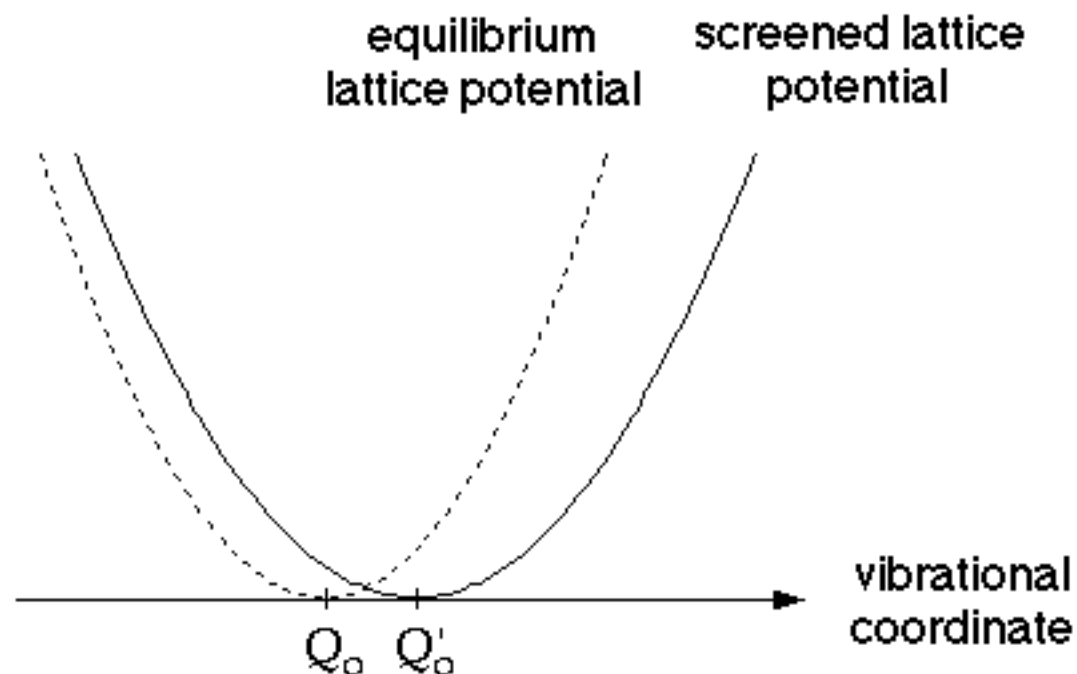

DISPLACIVE EXCITATION

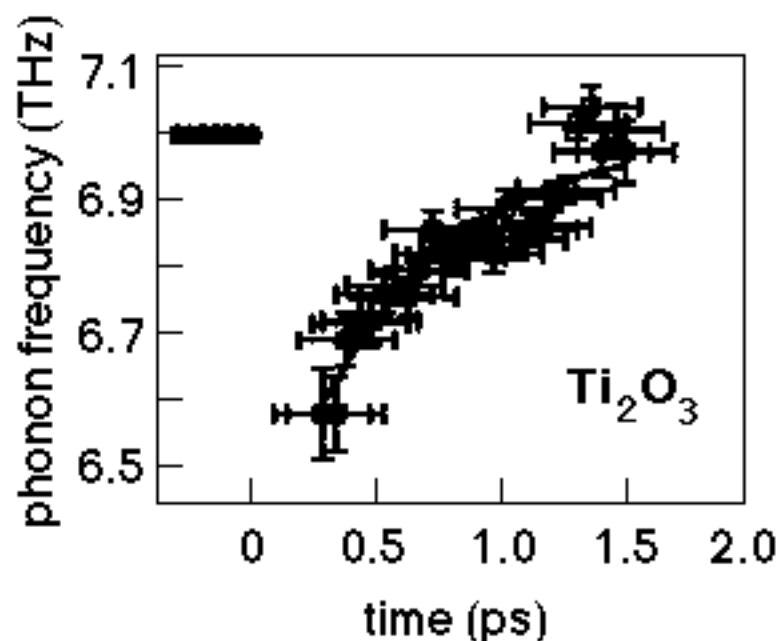
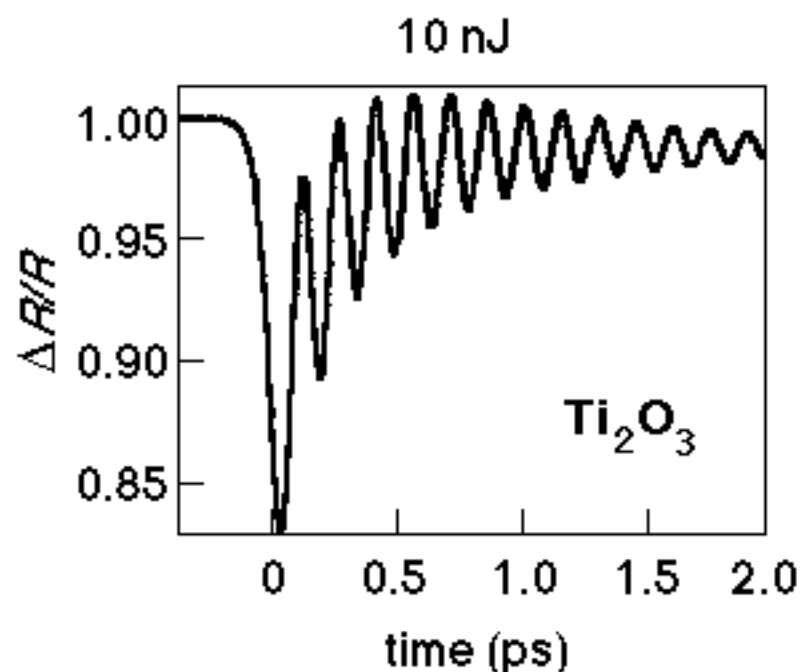

BEYOND PHONONS

intense pulses can 'melt' GaAs, Si, but how?

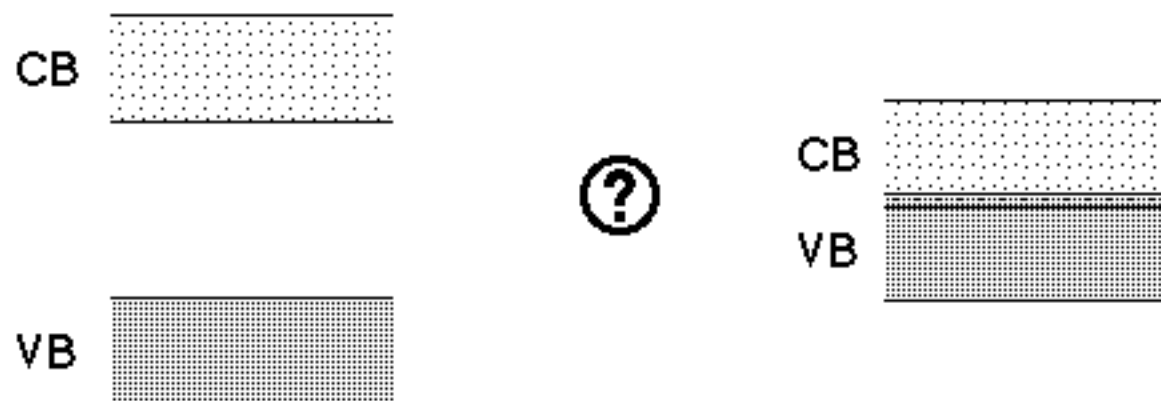

BEYOND PHONONS

intrinsic properties

measured properties

$\epsilon', \epsilon''(\omega)$ \longrightarrow R

$\epsilon', \epsilon''(\omega)$
 $\epsilon', \epsilon''(2\omega)$ \longrightarrow SHG
 $\chi_{(2)}$



2.2 eV DIELECTRIC CONSTANT

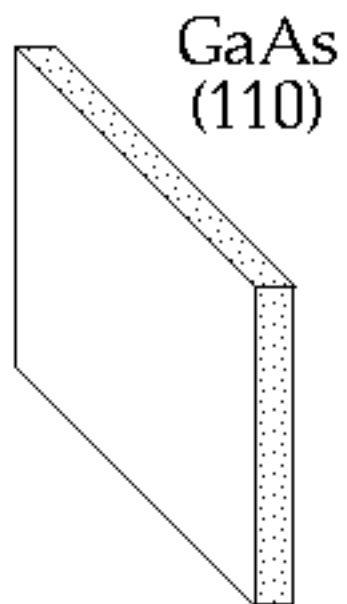

2.2 eV DIELECTRIC CONSTANT

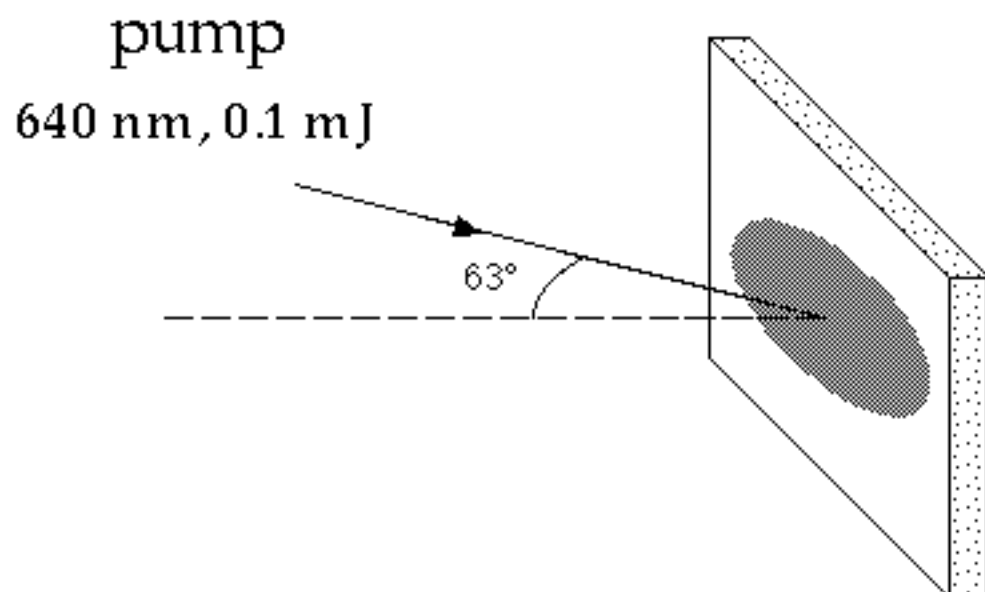

2.2 eV DIELECTRIC CONSTANT

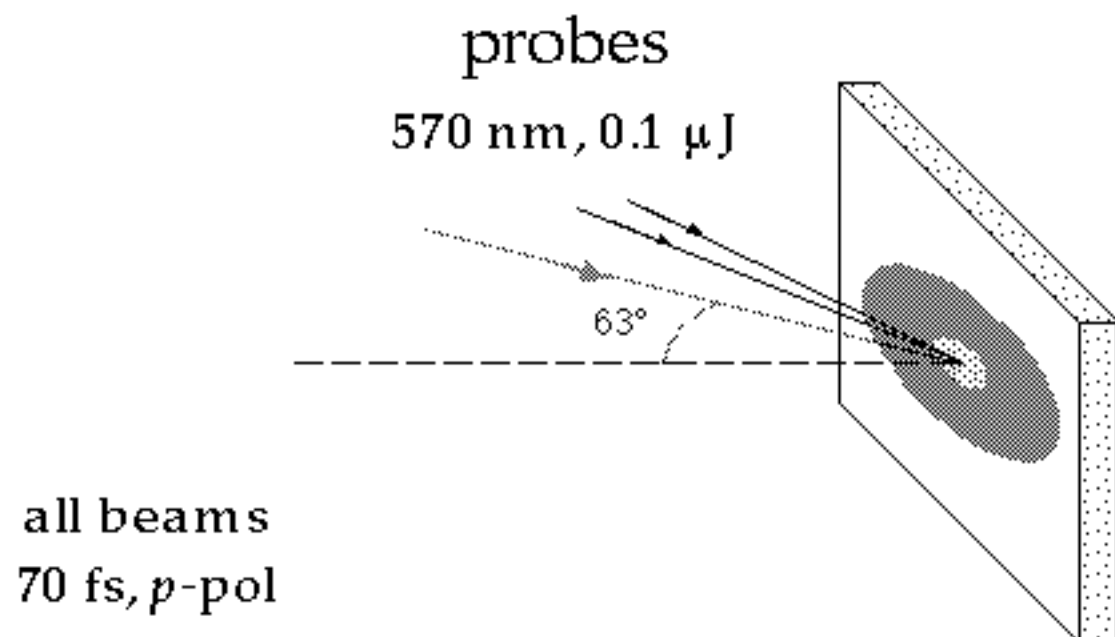

2.2 eV DIELECTRIC CONSTANT

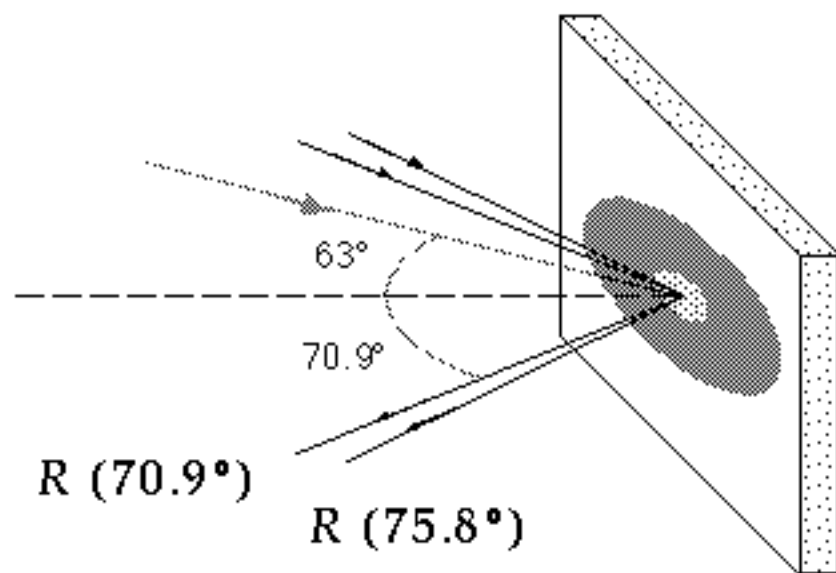

SETUP

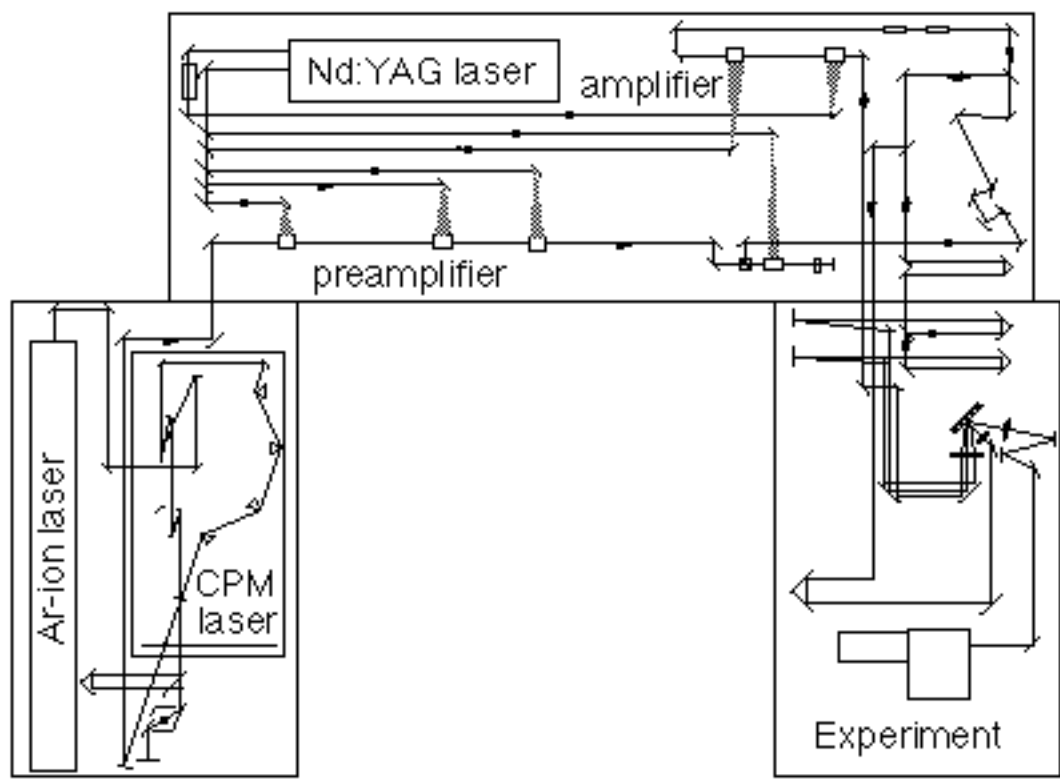

TIME DEPENDENCE

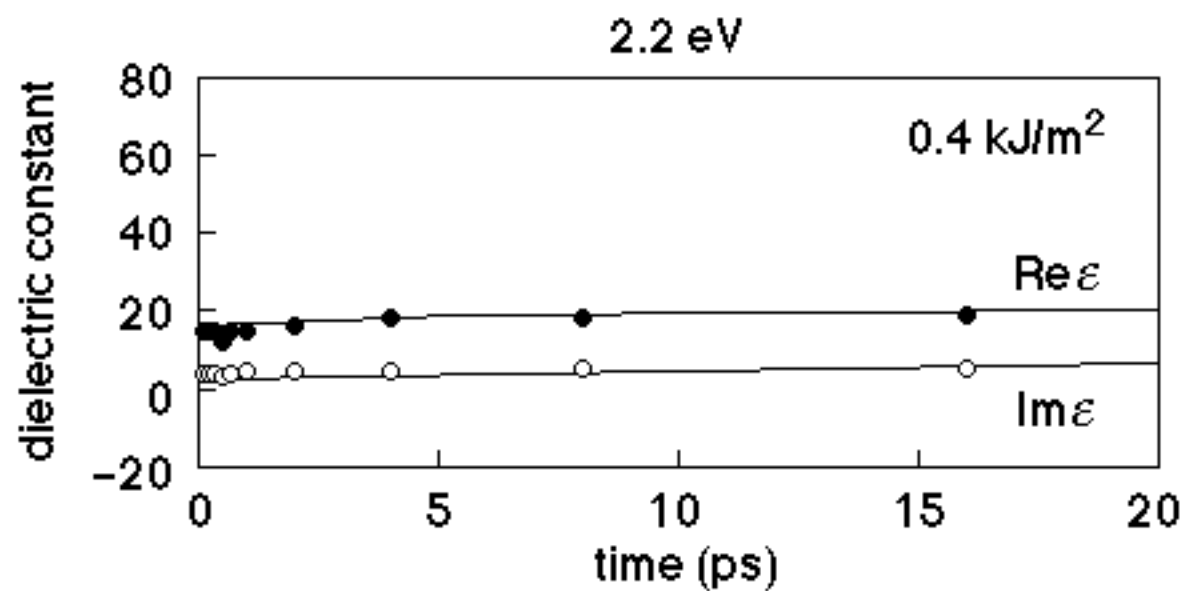

TIME DEPENDENCE

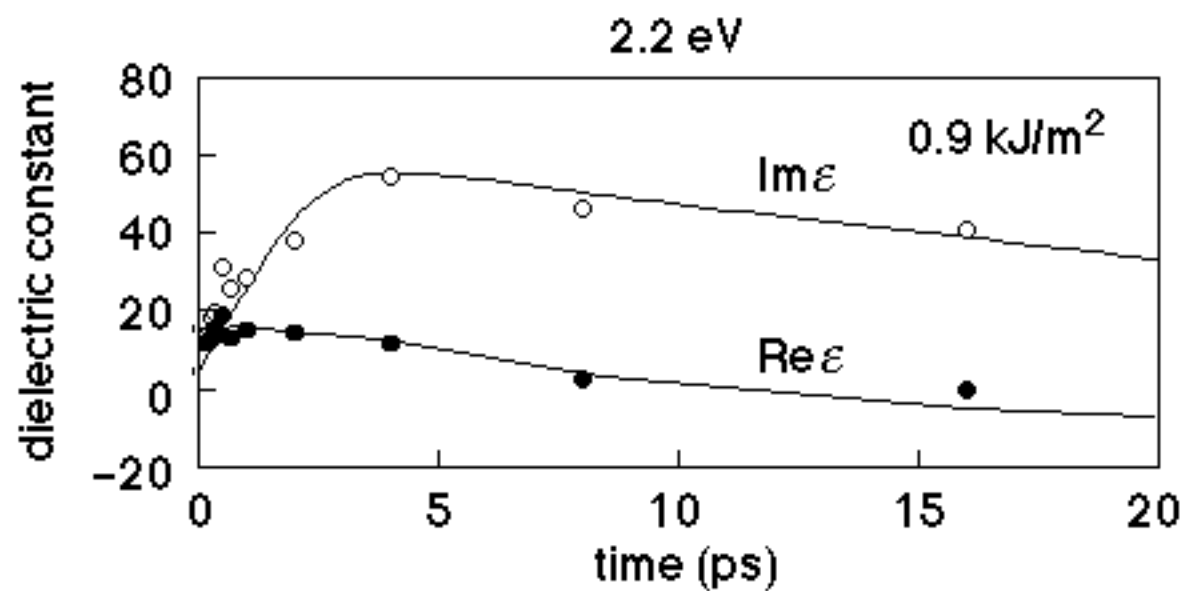

TIME DEPENDENCE

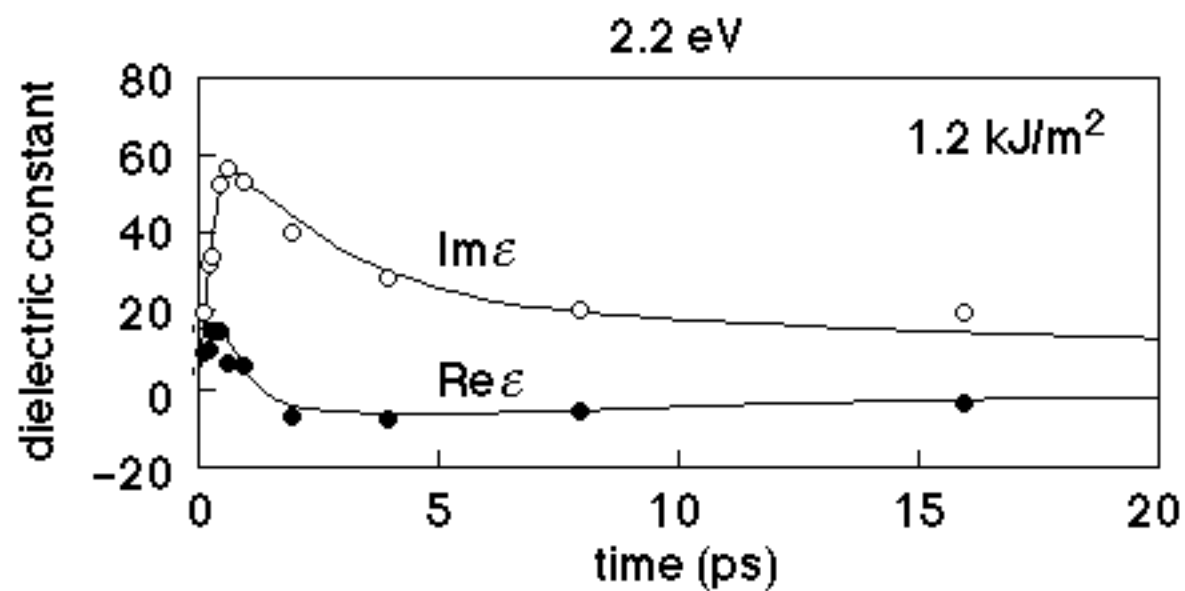

TIME DEPENDENCE

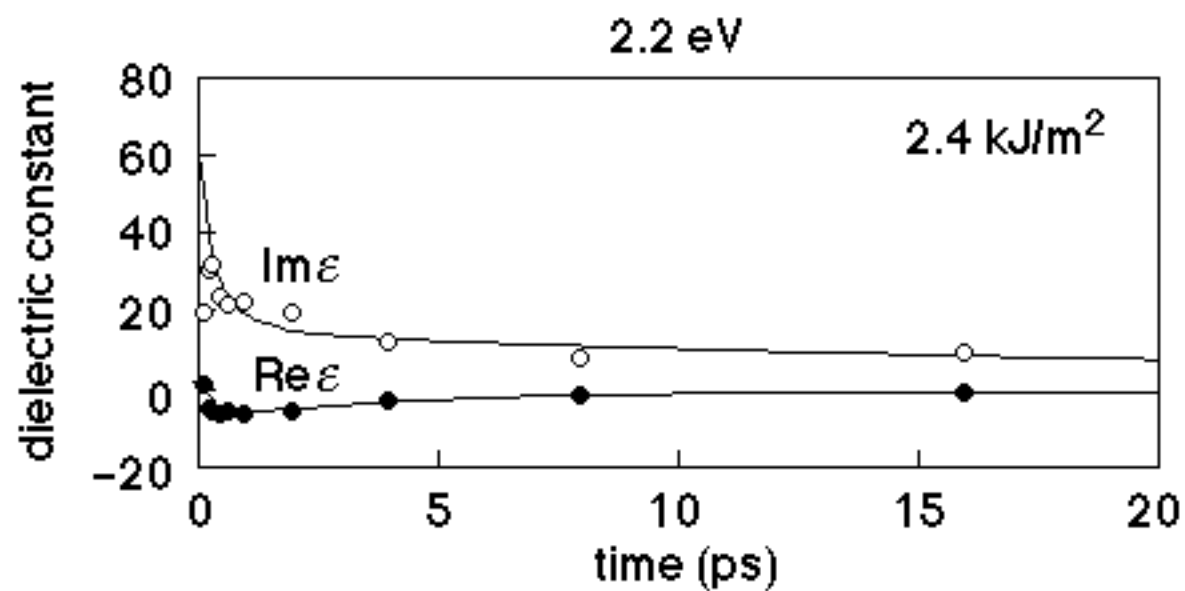

FLUENCE DEPENDENCE

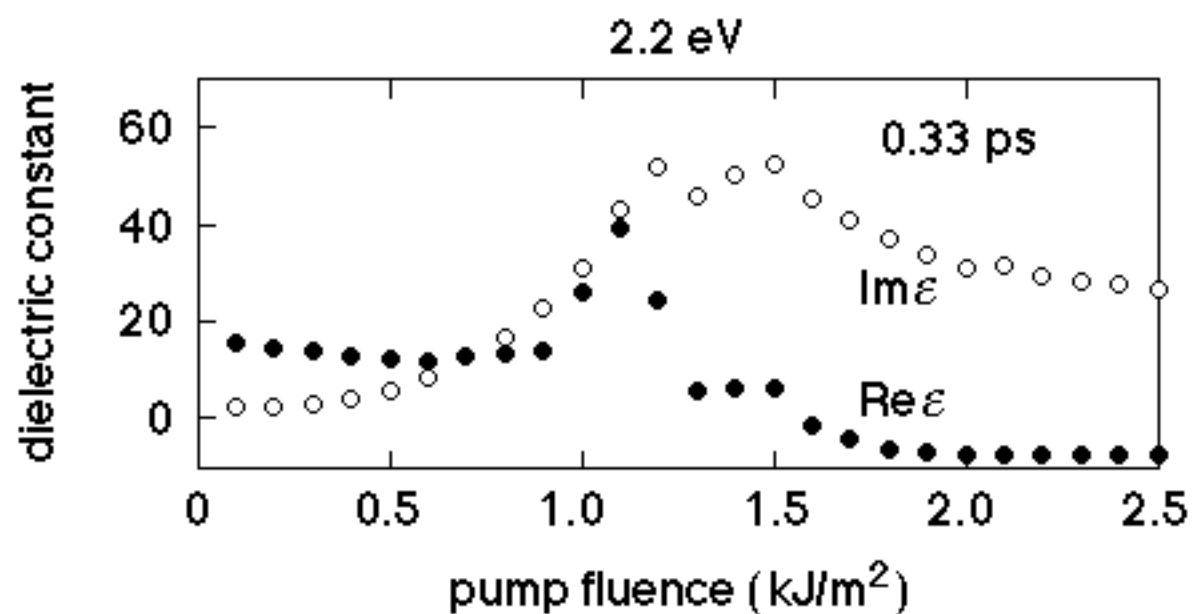

FLUENCE DEPENDENCE

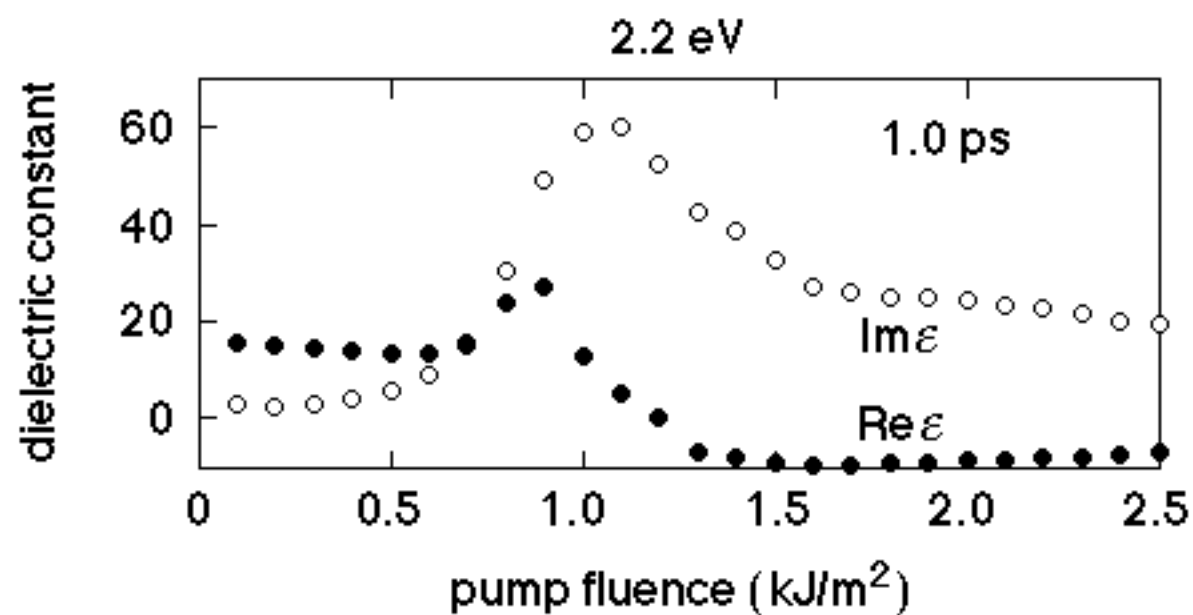

FLUENCE DEPENDENCE

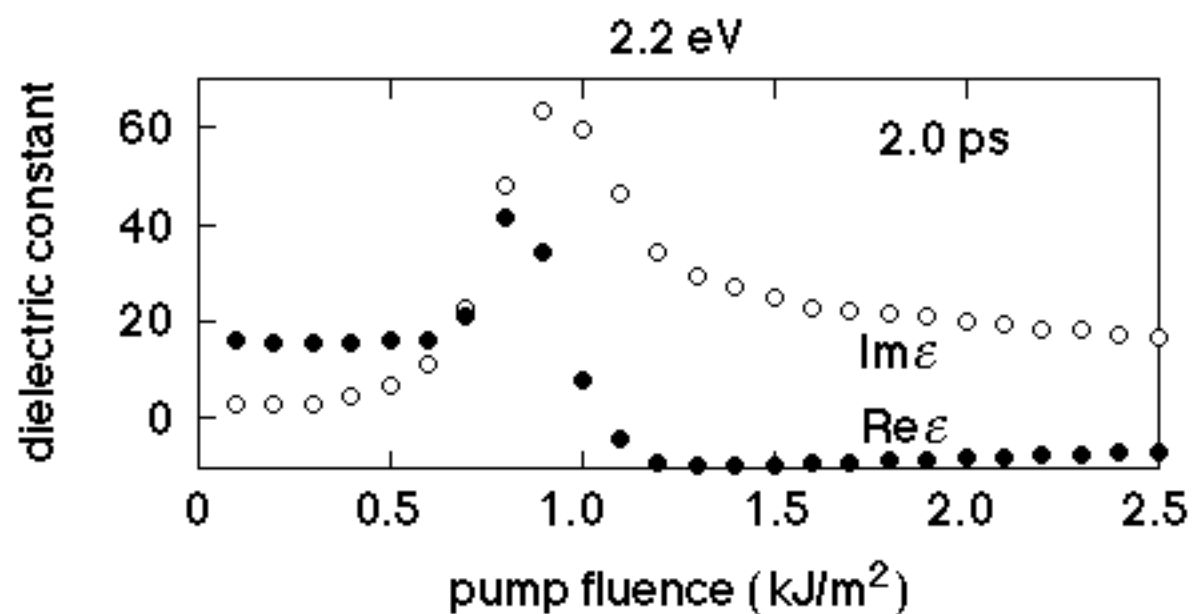

FLUENCE DEPENDENCE

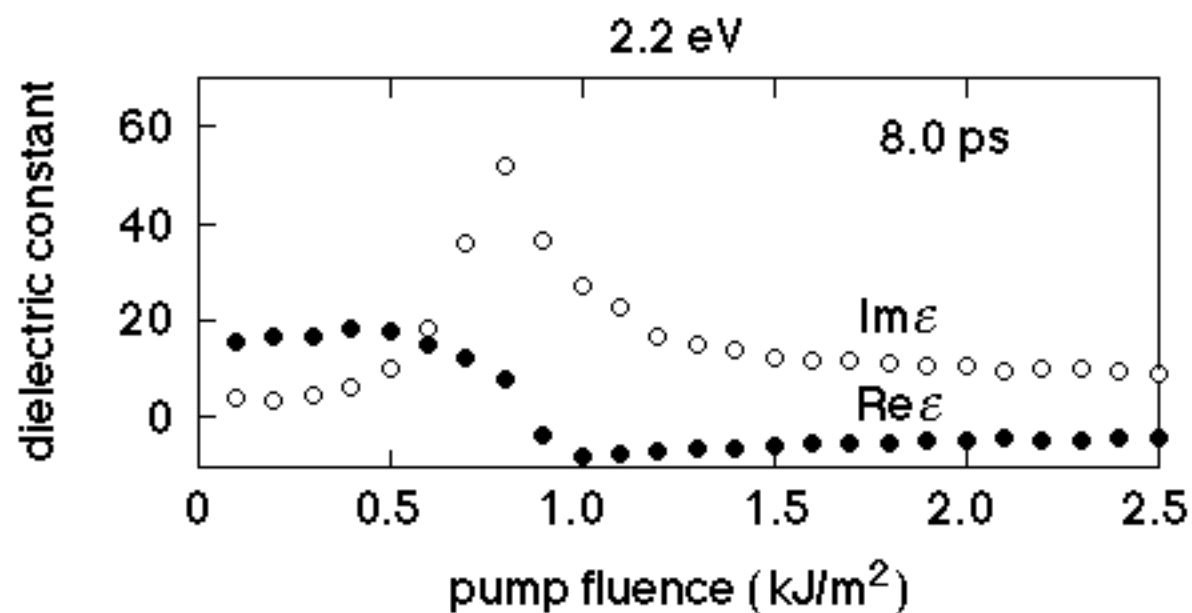

REVERSIBLE vs. IRREVERSIBLE

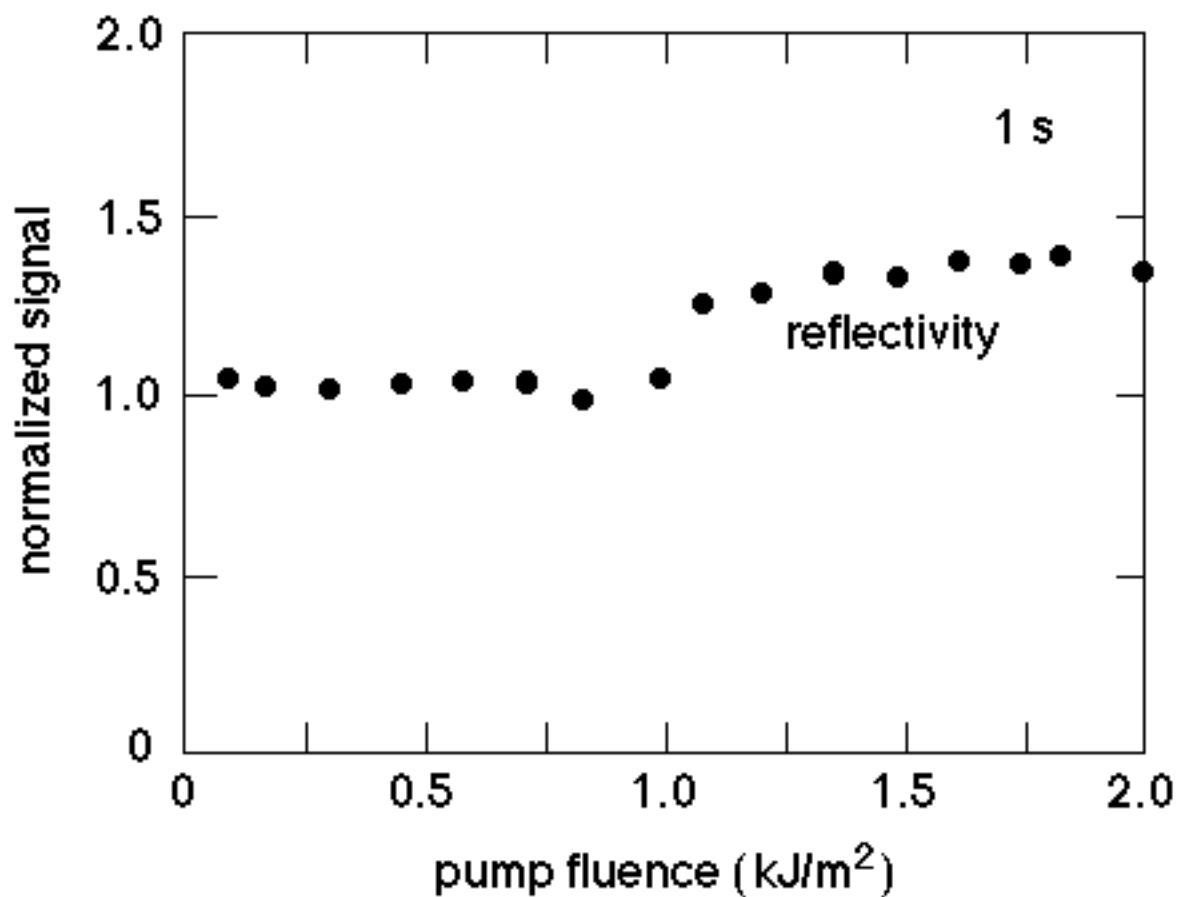

REVERSIBLE vs. IRREVERSIBLE

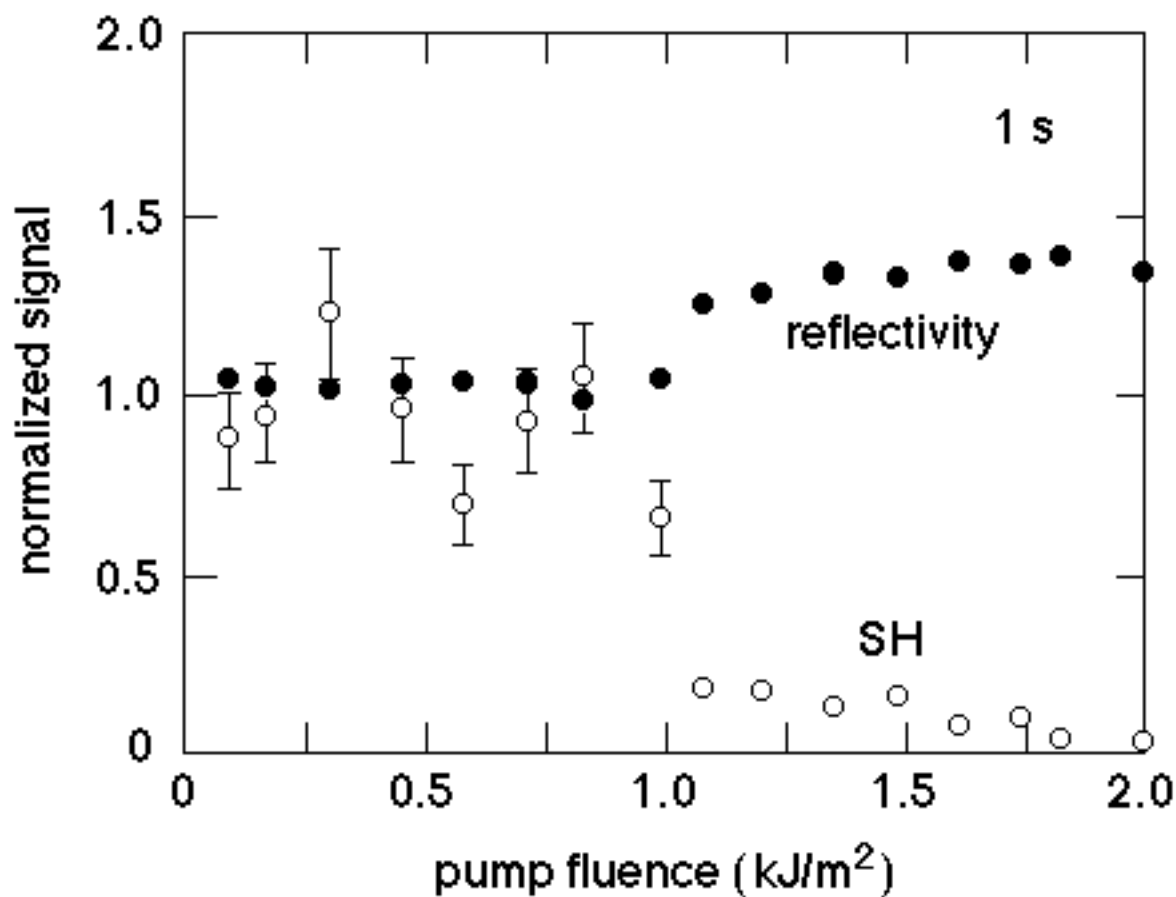

SIMPLE MODEL

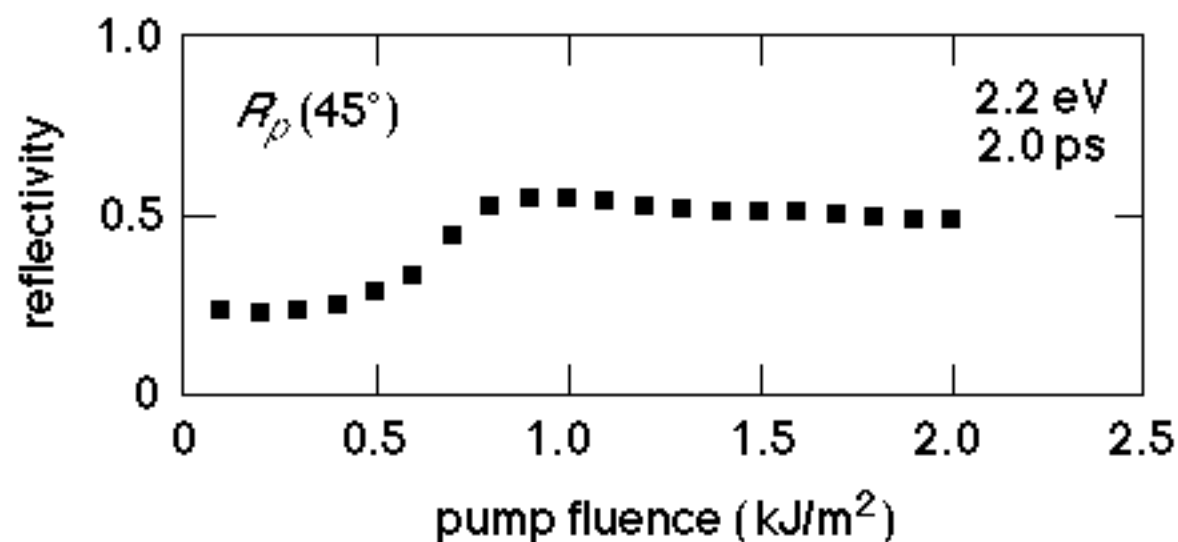

Drude model:

$$\text{Re}(\epsilon) = 1 - \frac{Ne^2}{m\epsilon_0} \frac{1}{\omega^2 + \gamma^2}$$

$$\text{Im}(\epsilon) = \frac{Ne^2}{m\epsilon_0} \frac{\gamma\omega}{\omega^4 + \gamma^2\omega^2}$$



SIMPLE MODEL

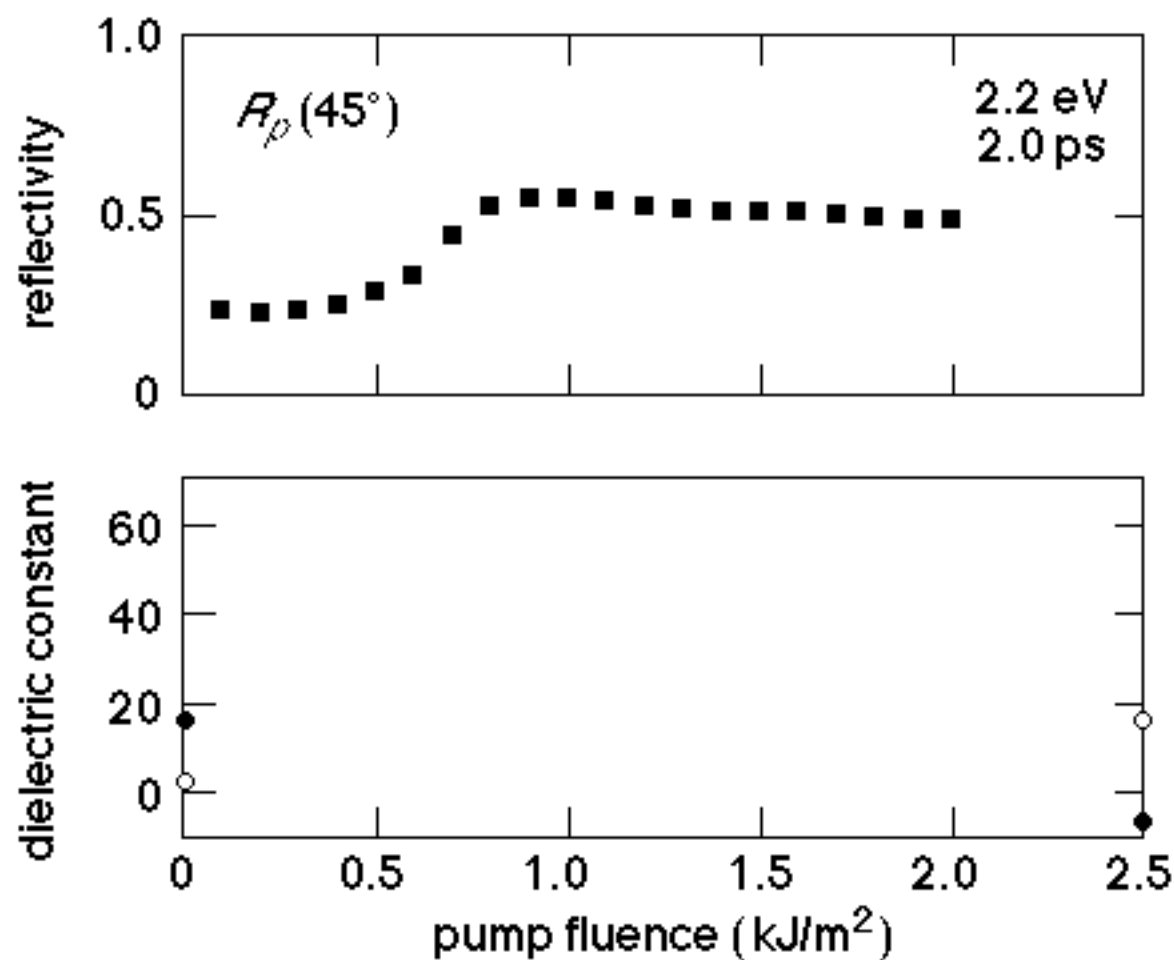

SIMPLE MODEL

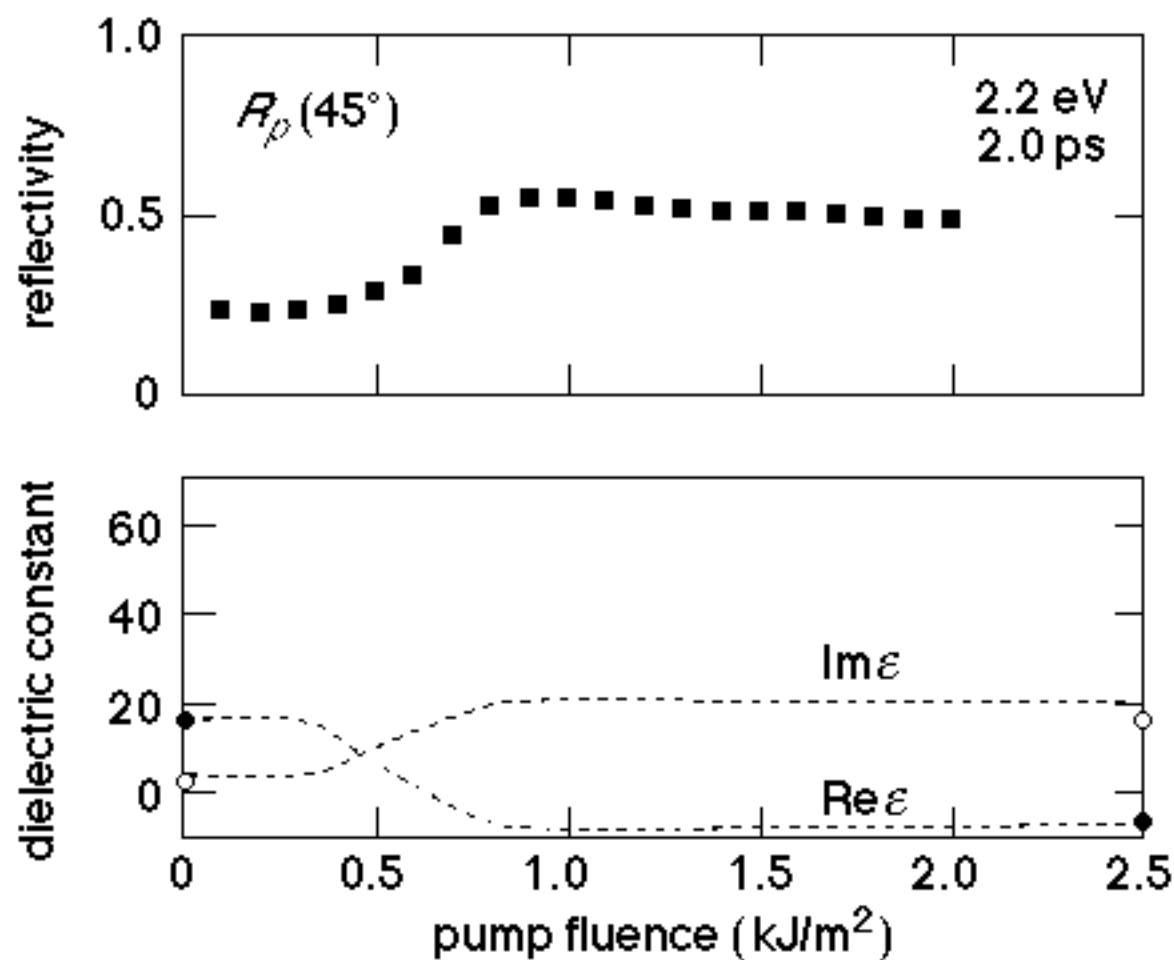

SIMPLE MODEL

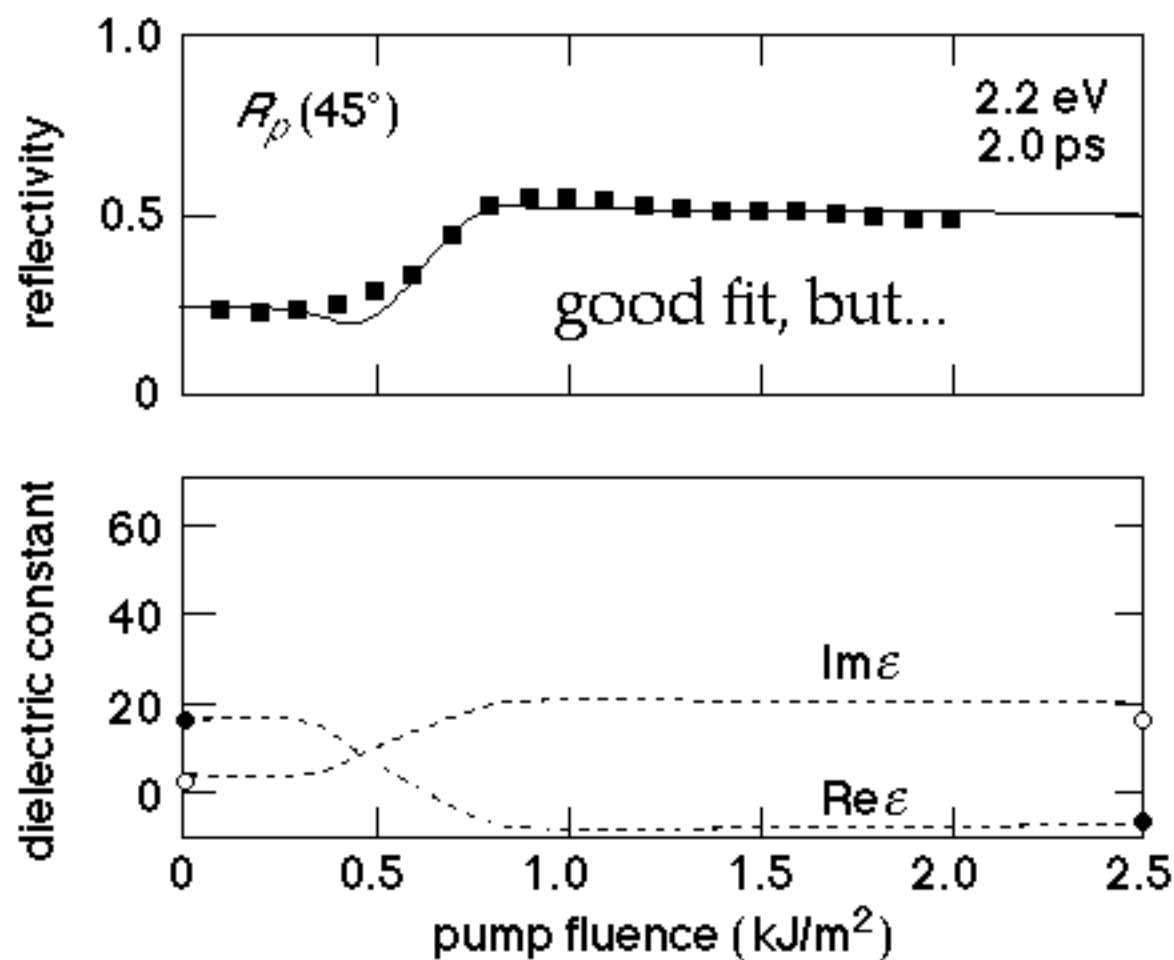

SIMPLE MODEL

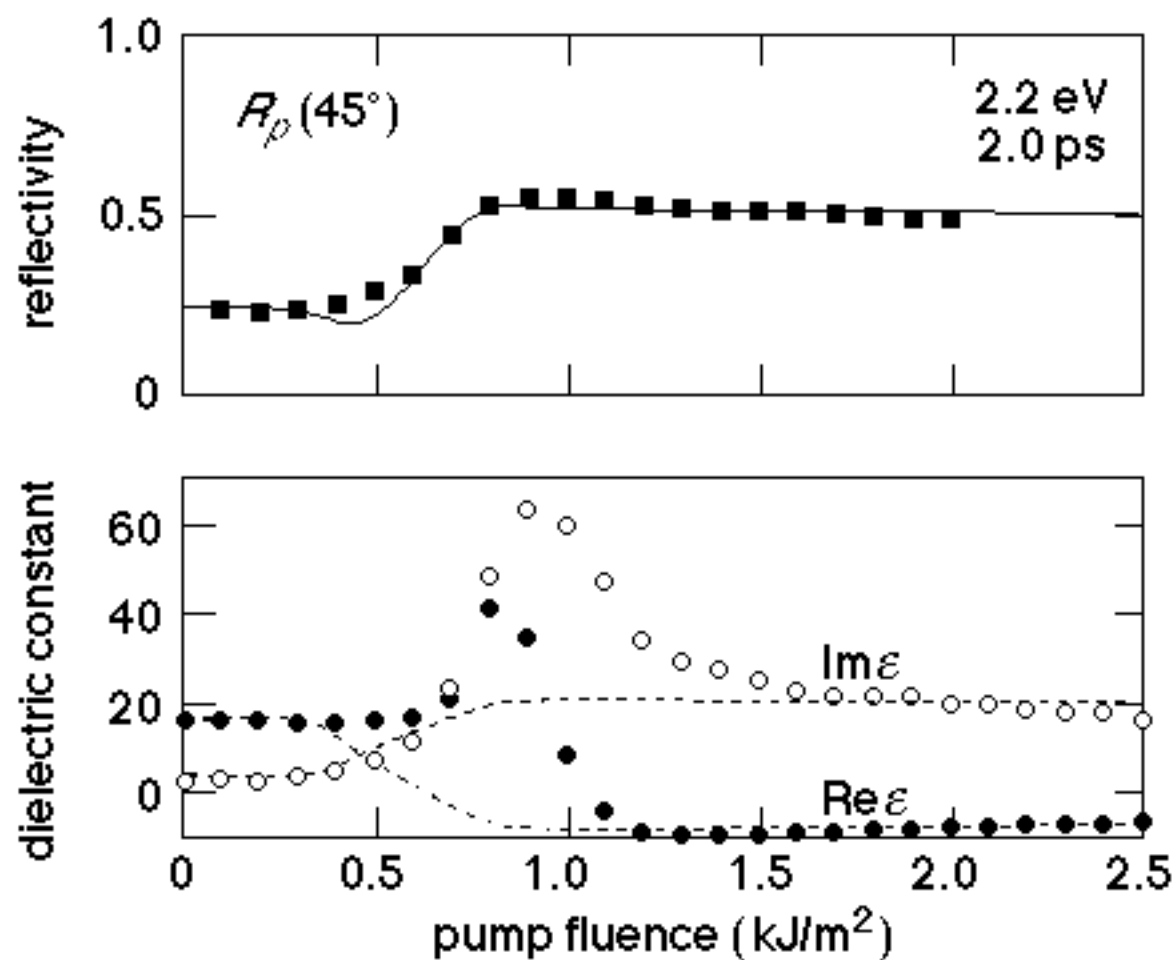

SIMPLE MODEL

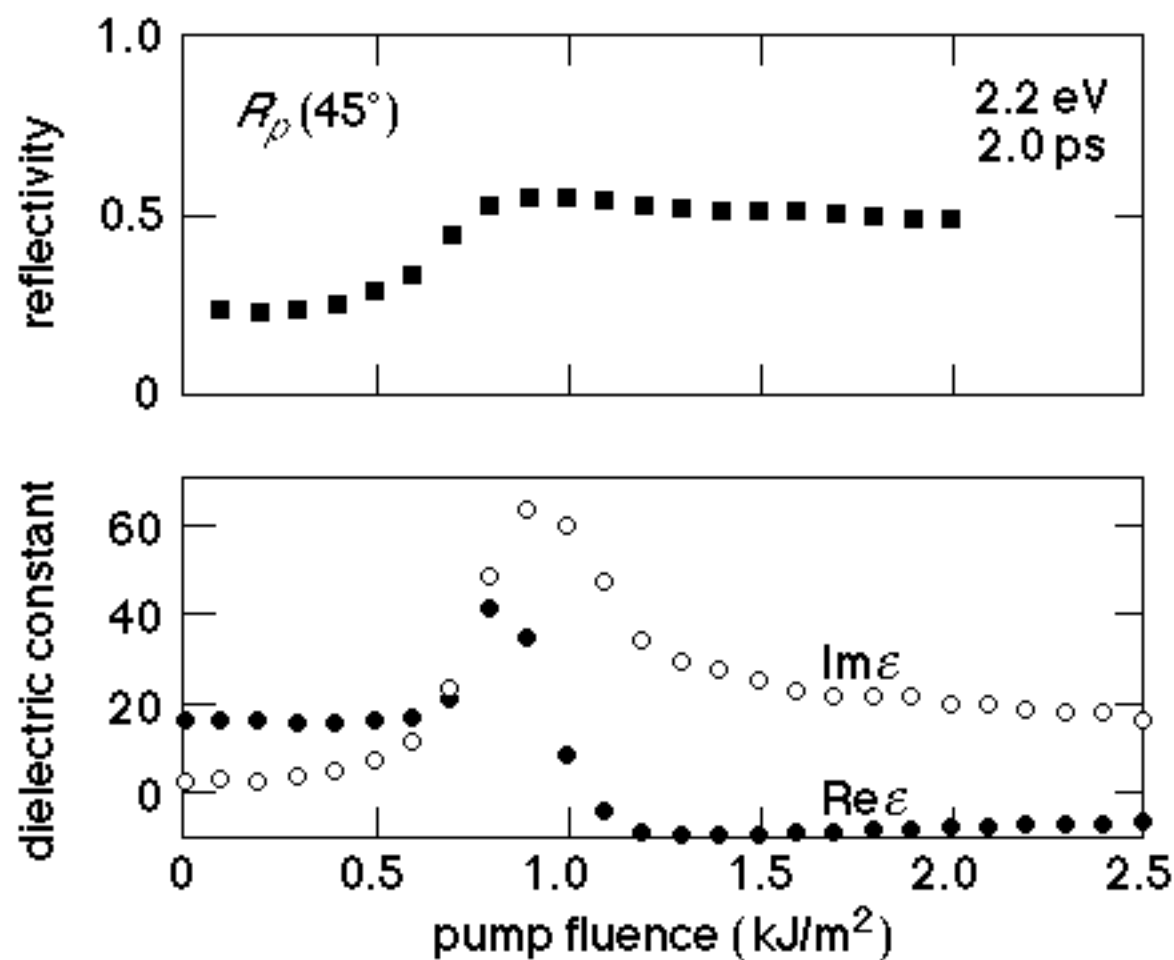

SIMPLE MODEL

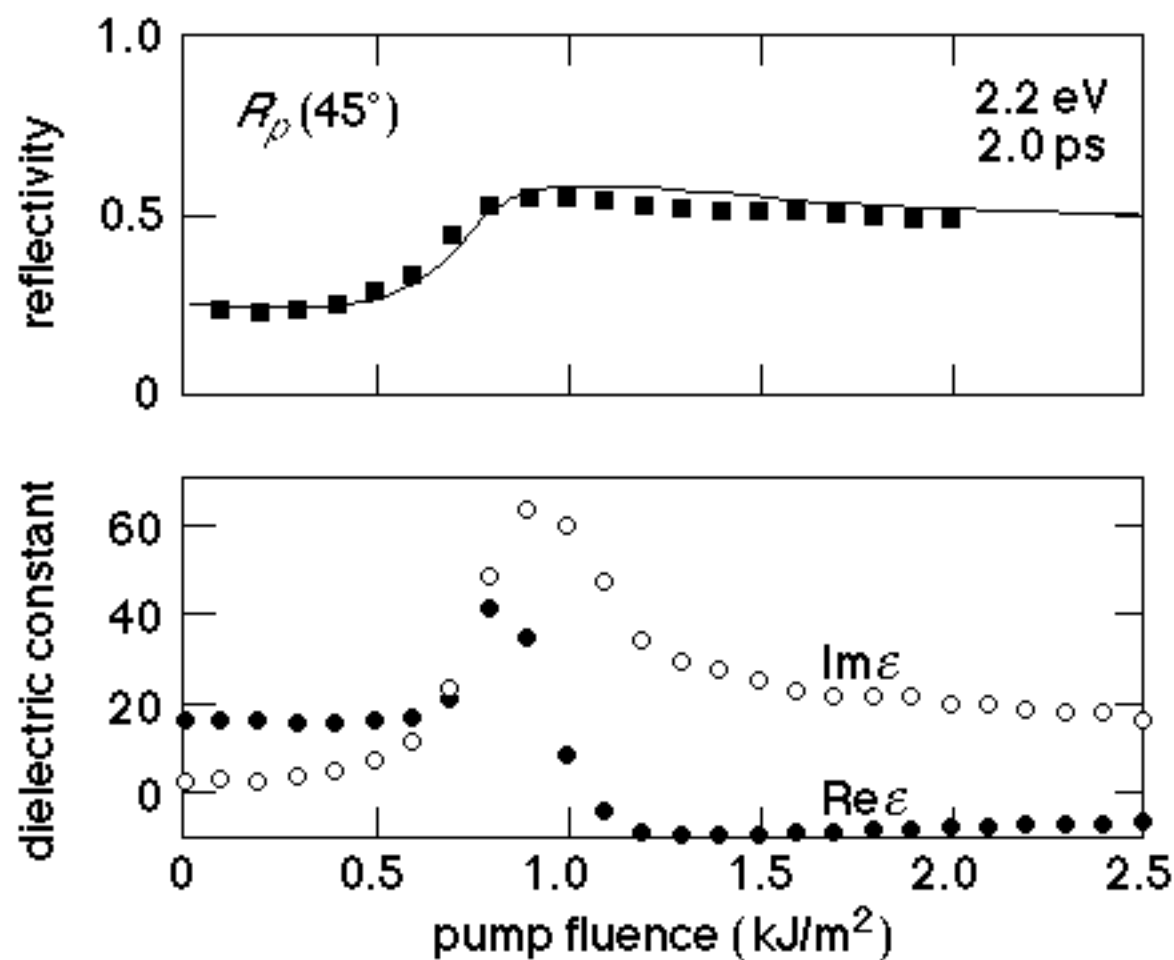

WHAT IS HAPPENING?

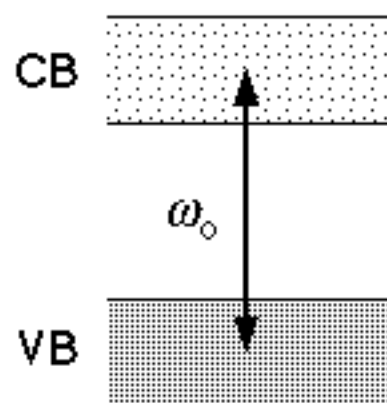

semiconductor

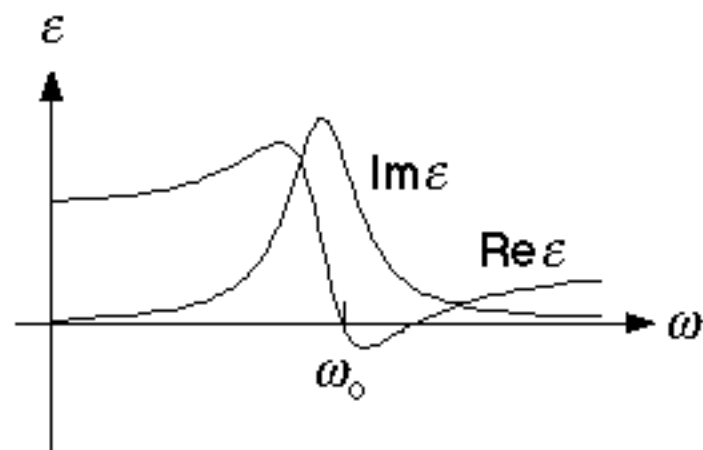

$$\omega_0 \approx 4.5 \text{ eV}$$



WHAT IS HAPPENING?

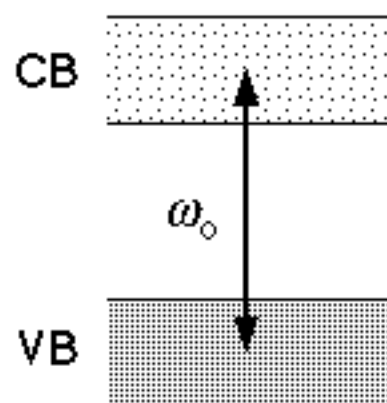

semiconductor

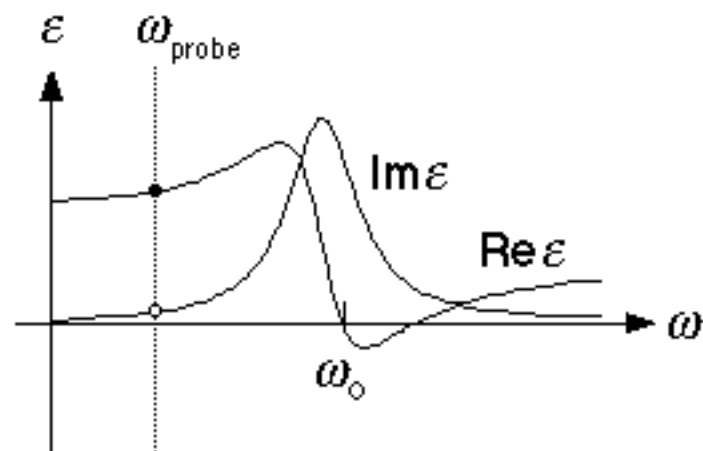

$$\omega_{\text{probe}} = 2.2 \text{ eV}$$



WHAT IS HAPPENING?

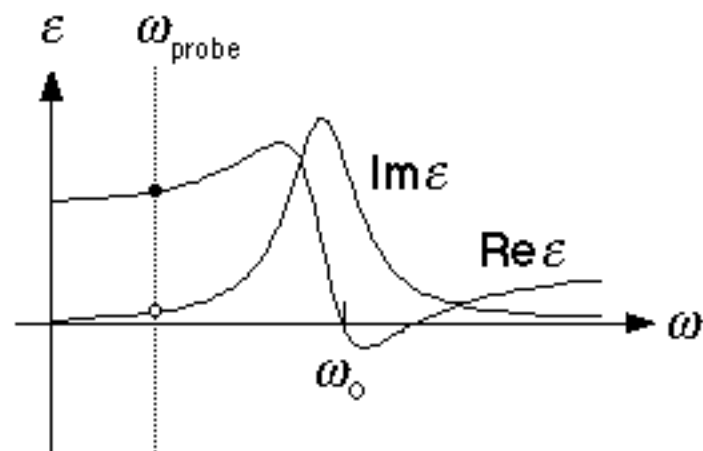
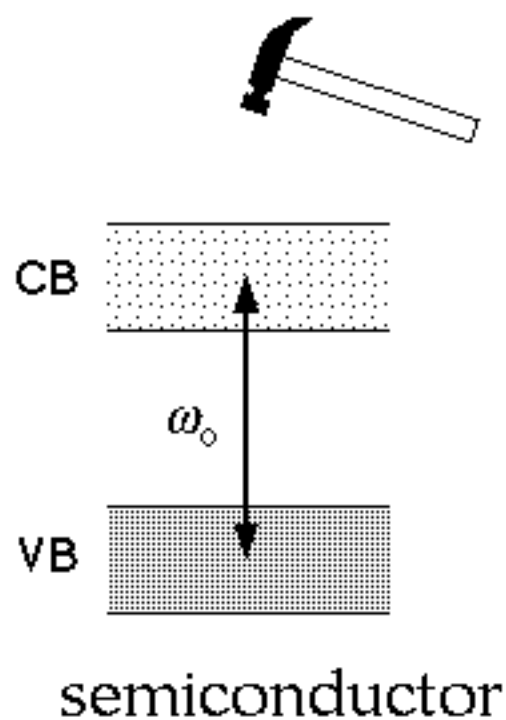

pump pulse excites
valence electrons...



WHAT IS HAPPENING?

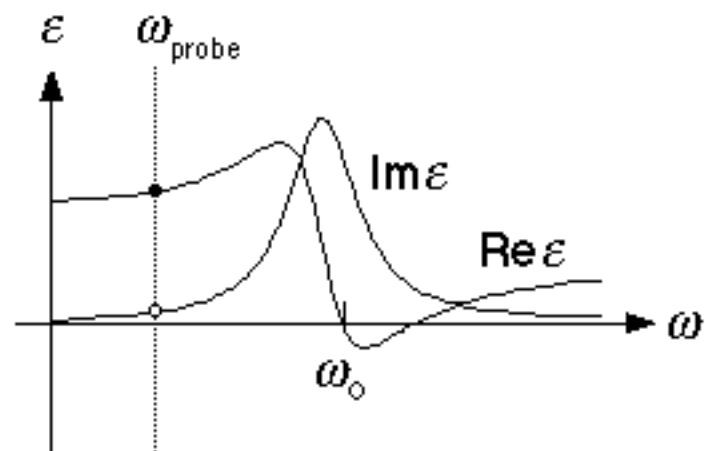
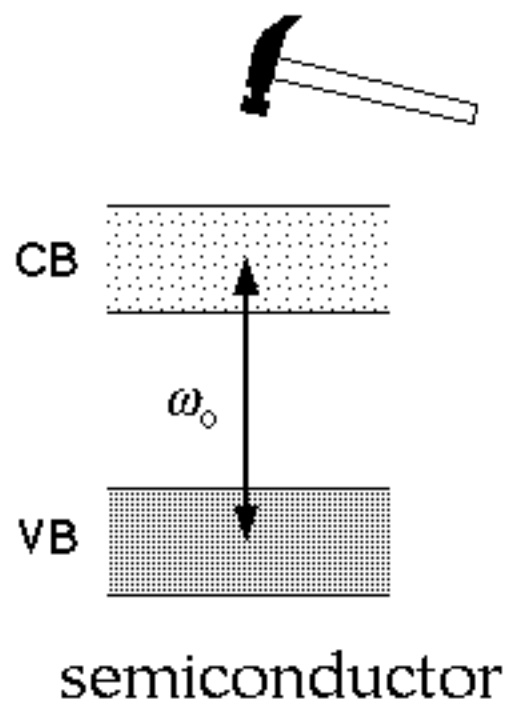

pump pulse excites
valence electrons...



WHAT IS HAPPENING?

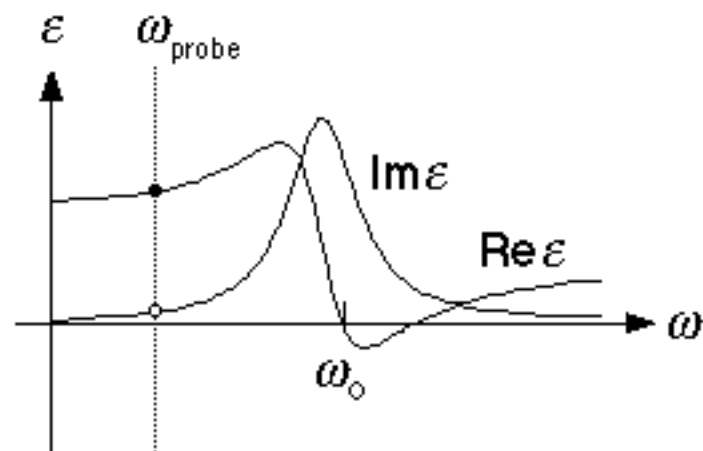
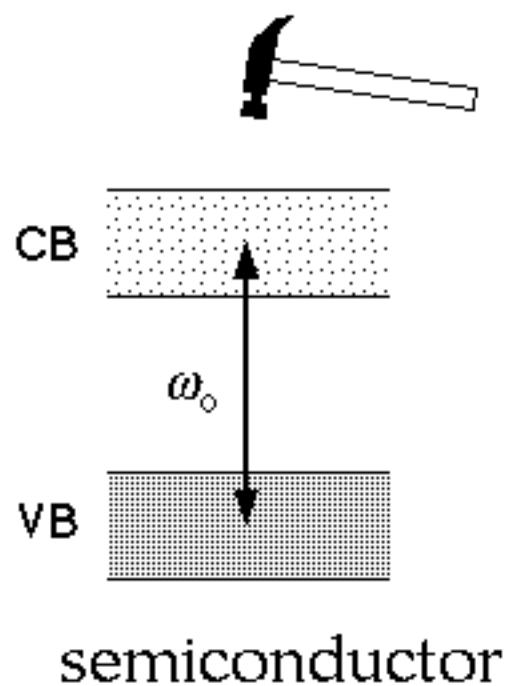

pump pulse excites
valence electrons...



WHAT IS HAPPENING?

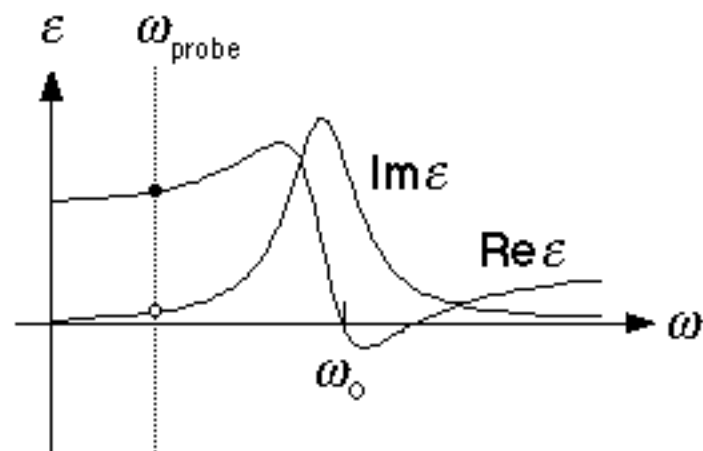
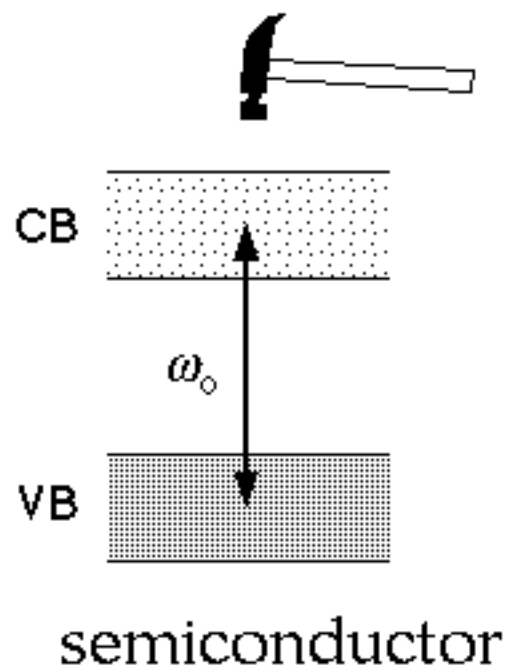

pump pulse excites
valence electrons...



WHAT IS HAPPENING?

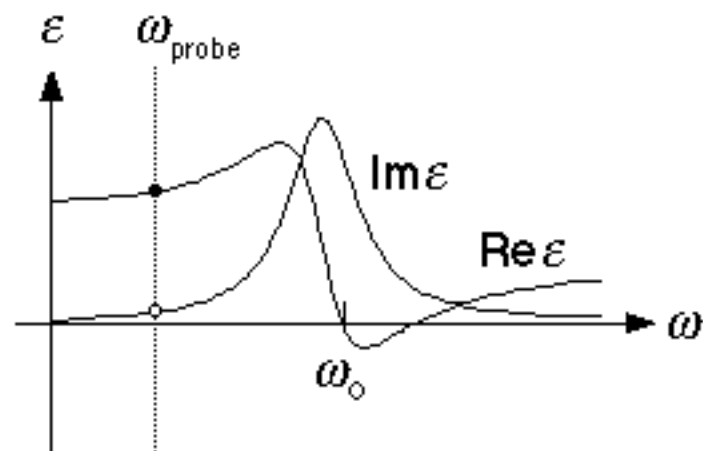
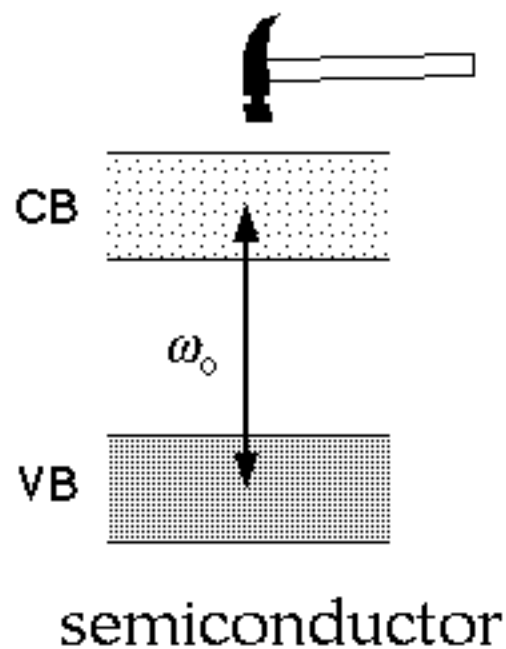

pump pulse excites
valence electrons...



WHAT IS HAPPENING?

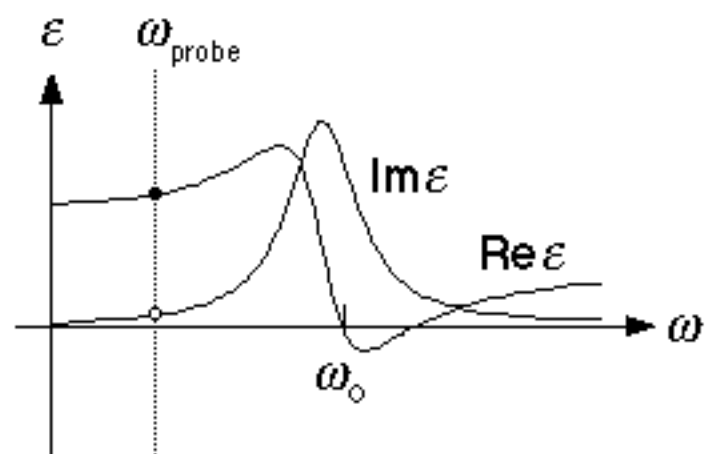
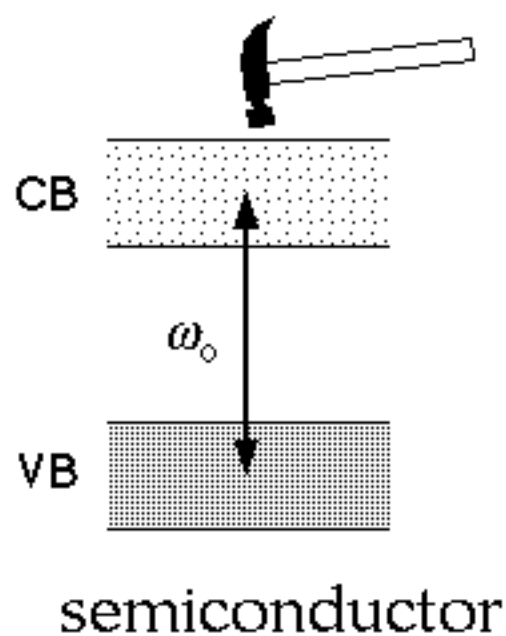

pump pulse excites
valence electrons...



WHAT IS HAPPENING?

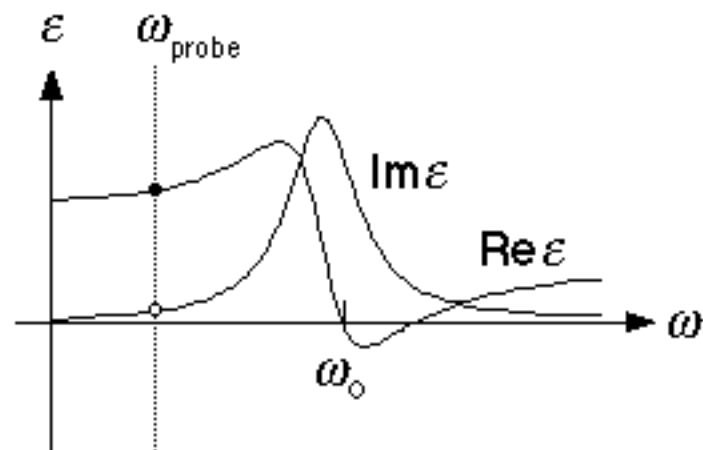
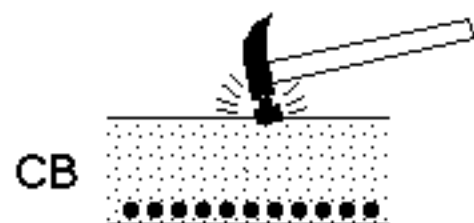

semiconductor

pump pulse excites
valence electrons...



WHAT IS HAPPENING?

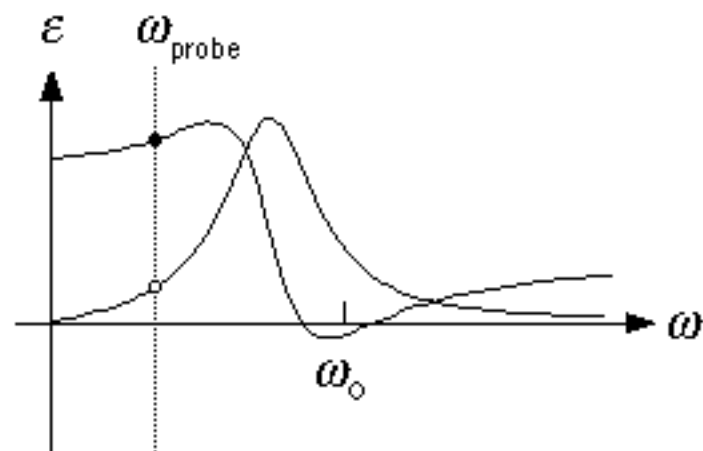
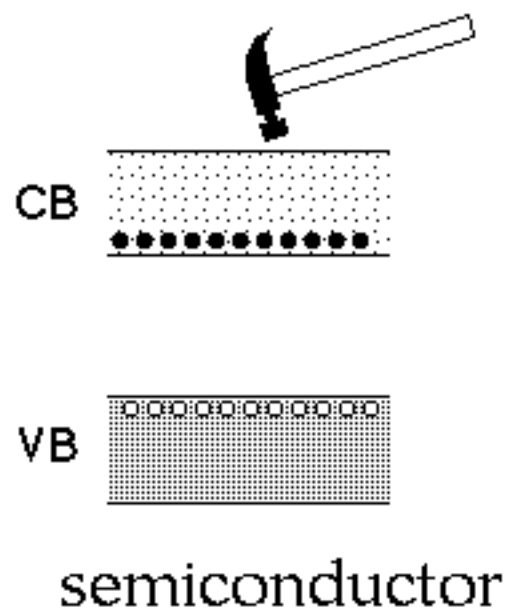

...and induces change
in bandstructure



WHAT IS HAPPENING?

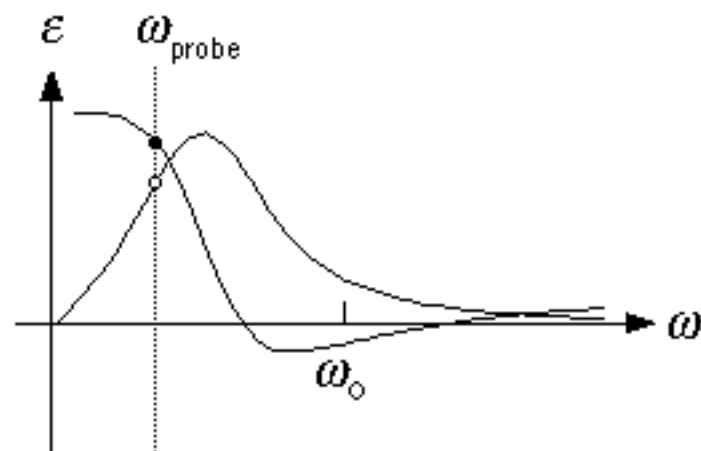
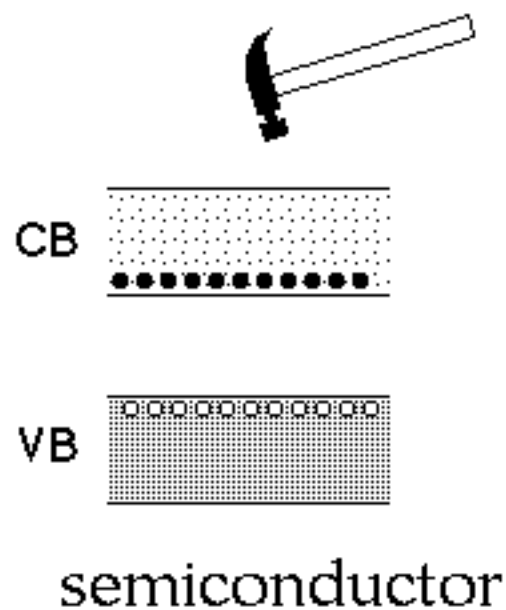

...and induces change
in bandstructure



WHAT IS HAPPENING?

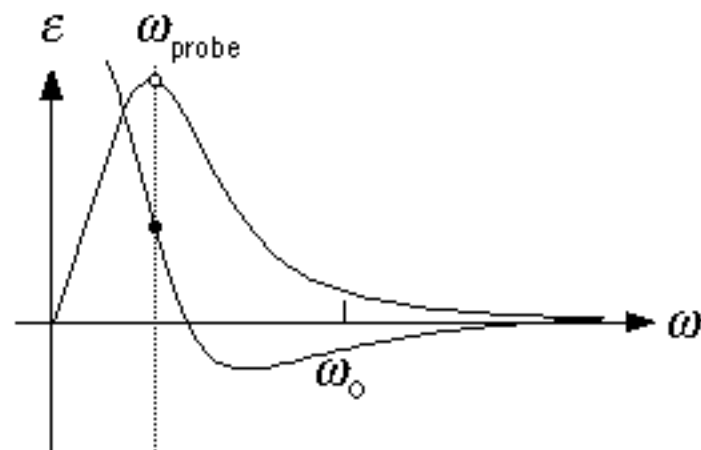
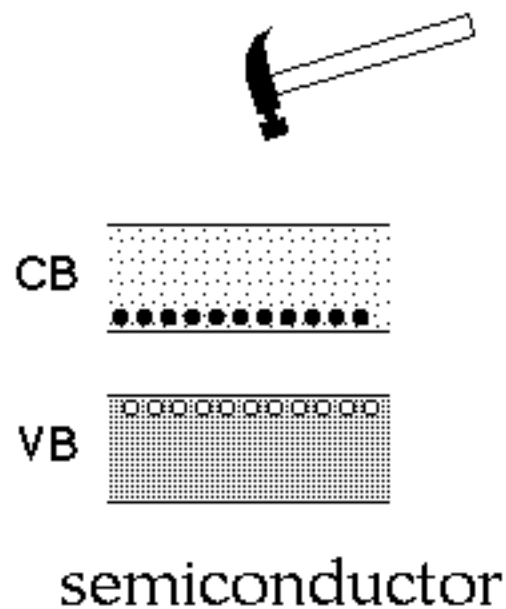

...and induces change
in bandstructure



WHAT IS HAPPENING?

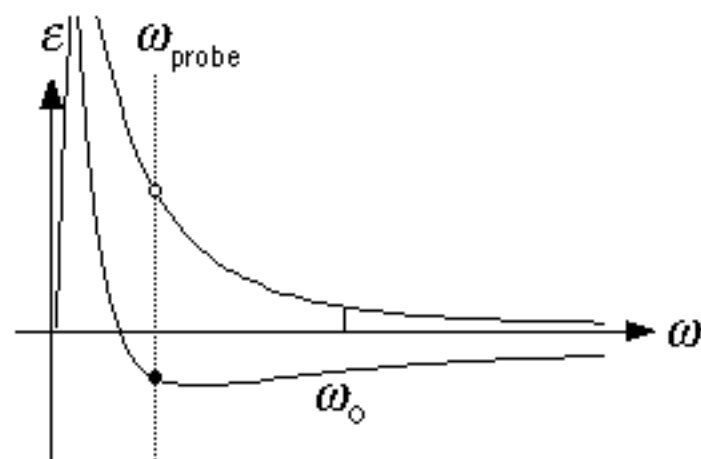
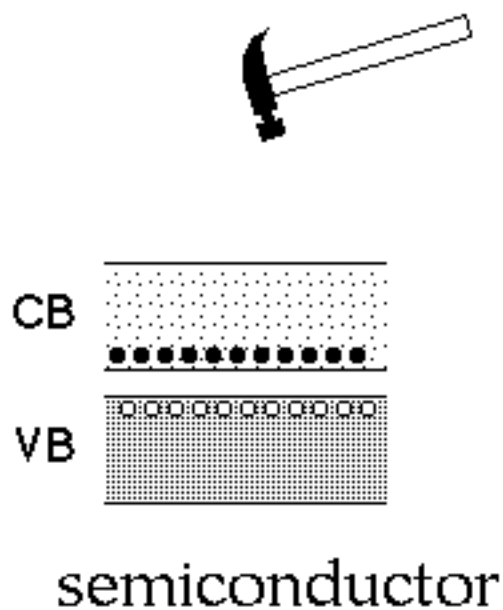

...and induces change
in bandstructure



WHAT IS HAPPENING?

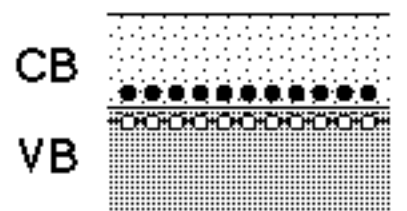
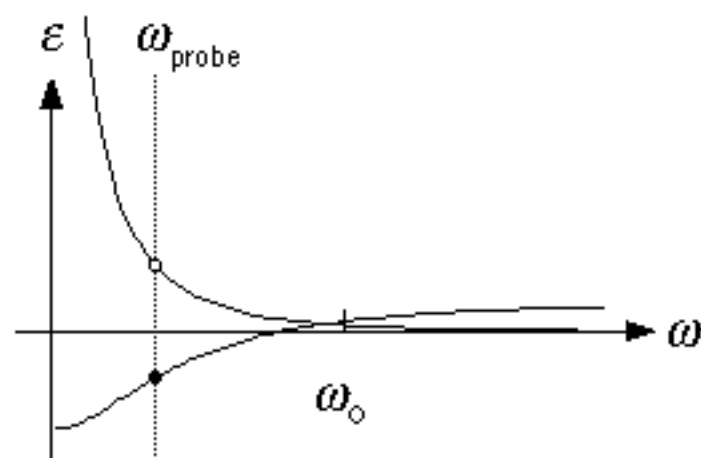

semimetal

...and induces change
in bandstructure



WHAT IS HAPPENING?

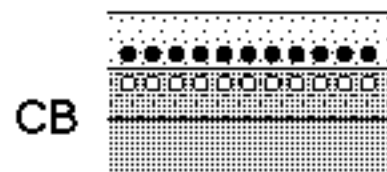
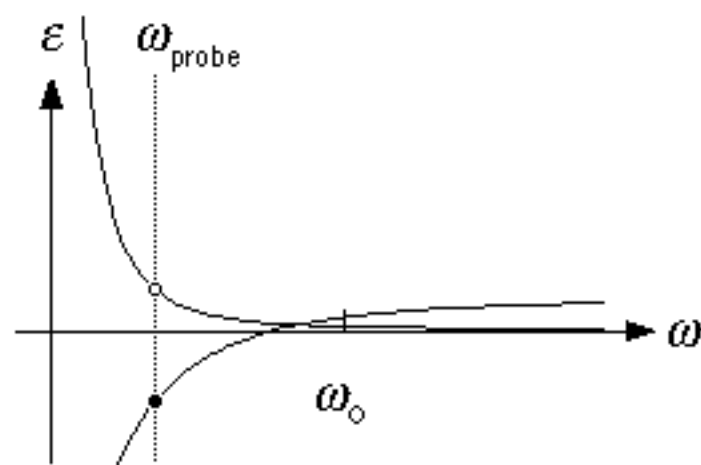
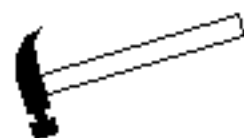

metal

...and induces change
in bandstructure



WHAT IS HAPPENING?

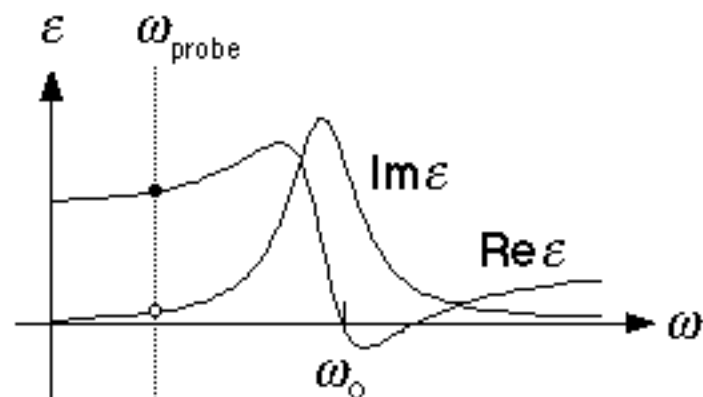
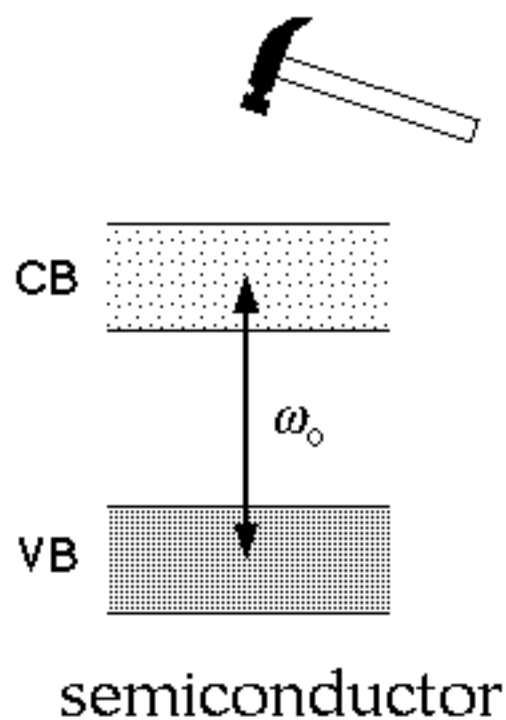

WHAT IS HAPPENING?

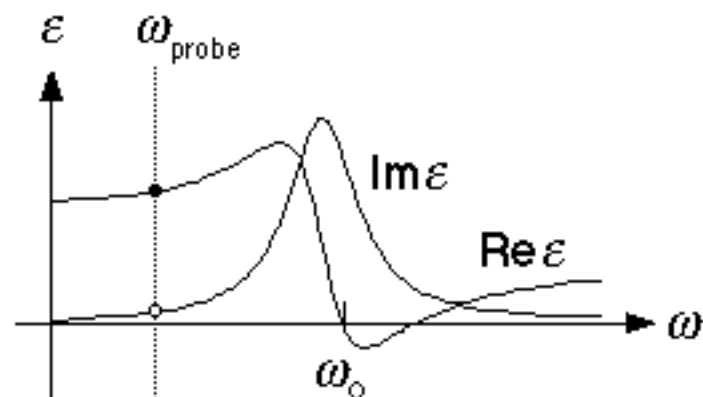
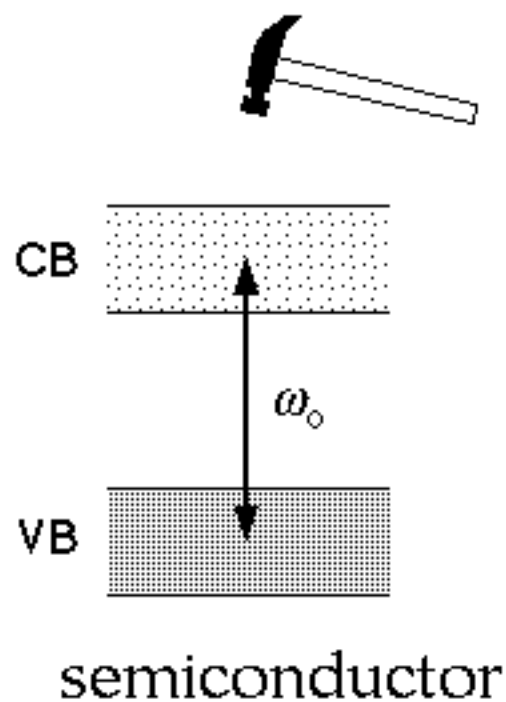

WHAT IS HAPPENING?

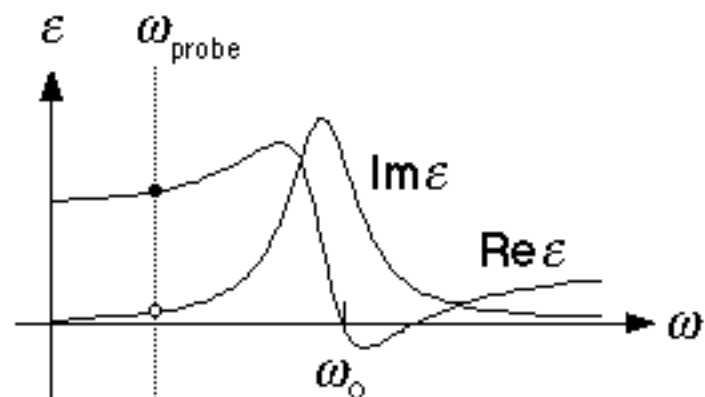
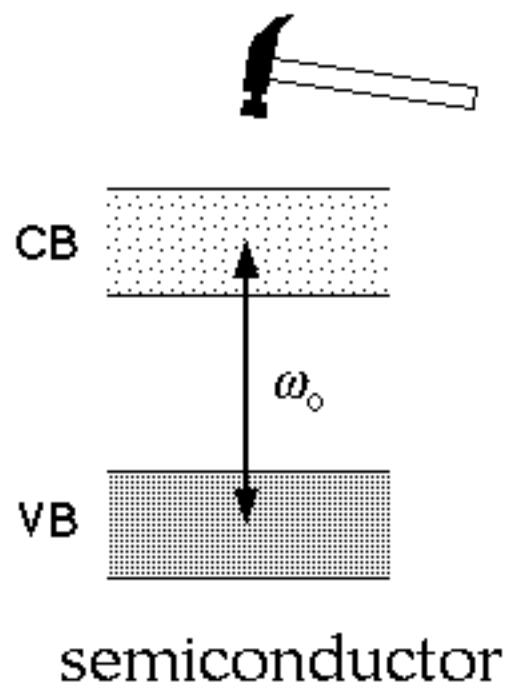

WHAT IS HAPPENING?

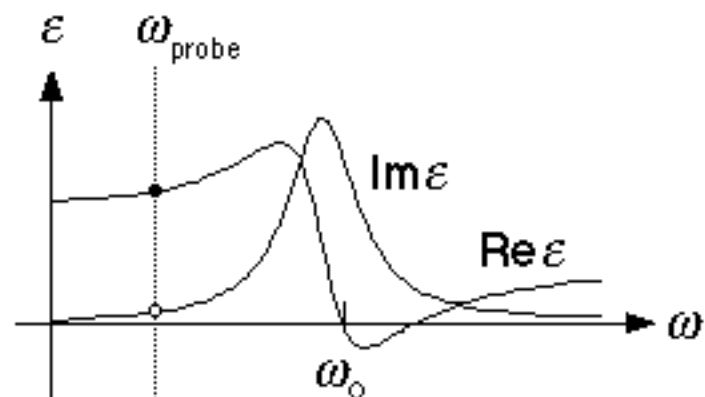
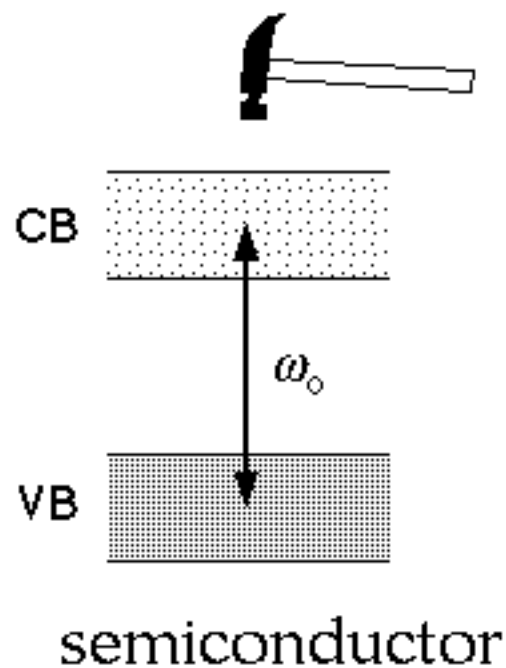

WHAT IS HAPPENING?

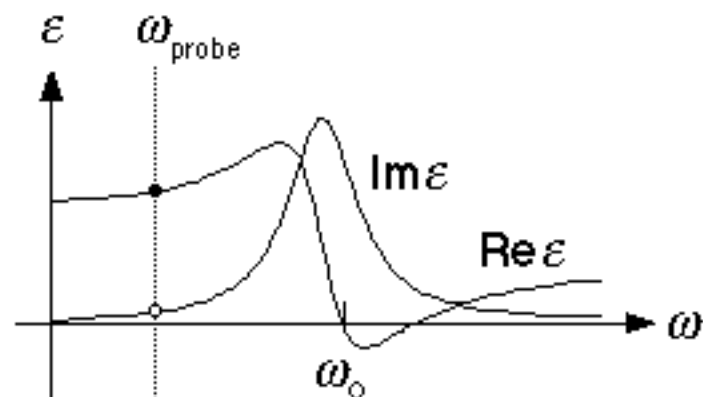
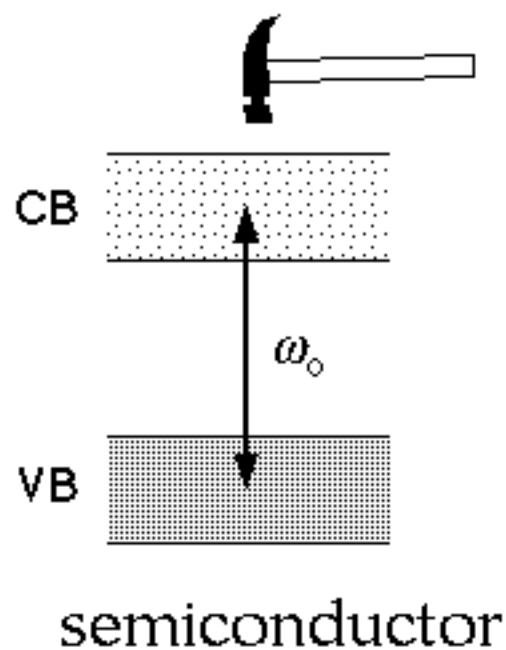

WHAT IS HAPPENING?

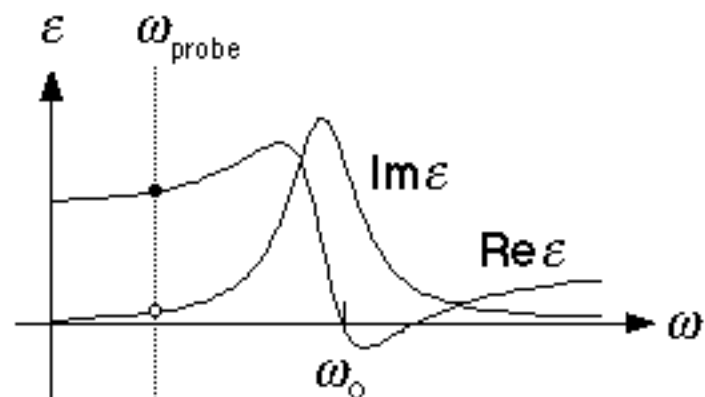
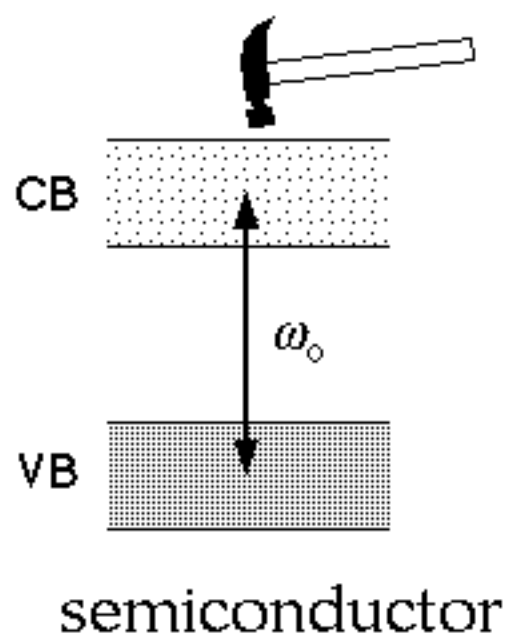

WHAT IS HAPPENING?

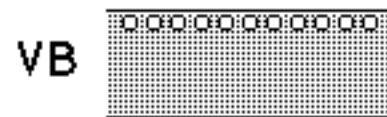
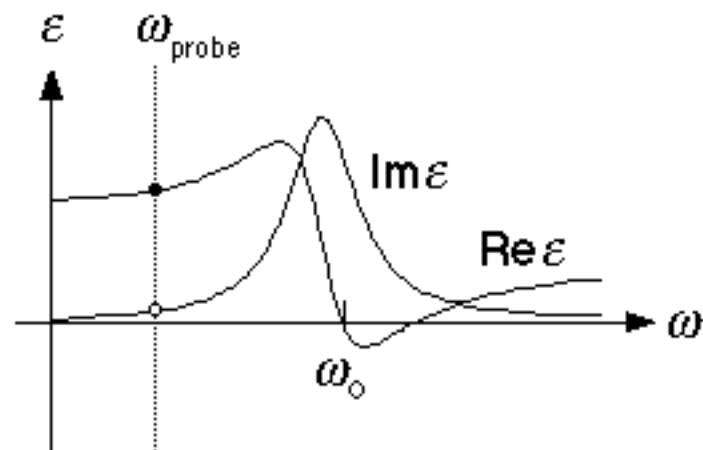
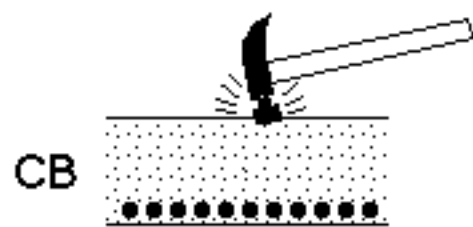

semiconductor



WHAT IS HAPPENING?

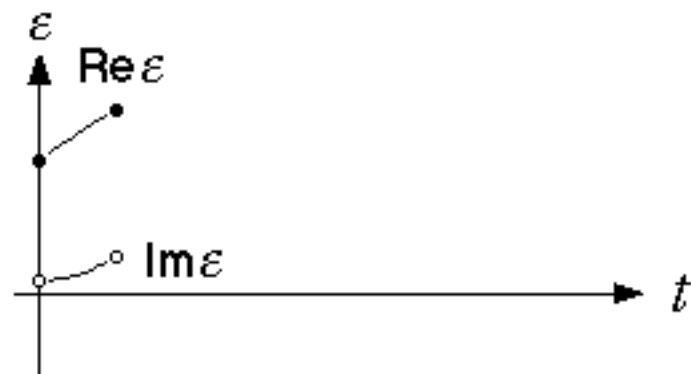
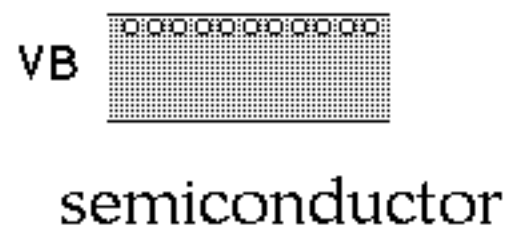
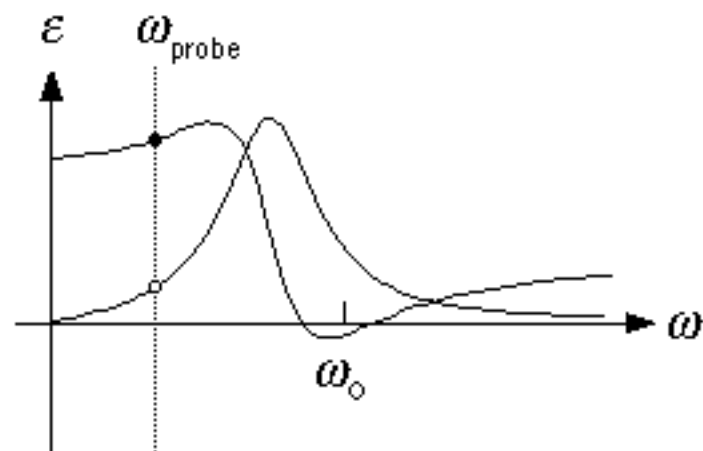
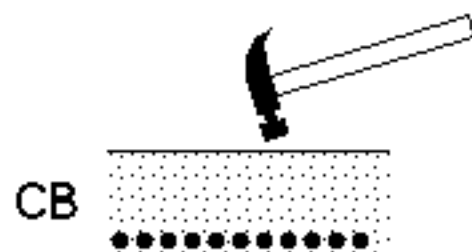

WHAT IS HAPPENING?

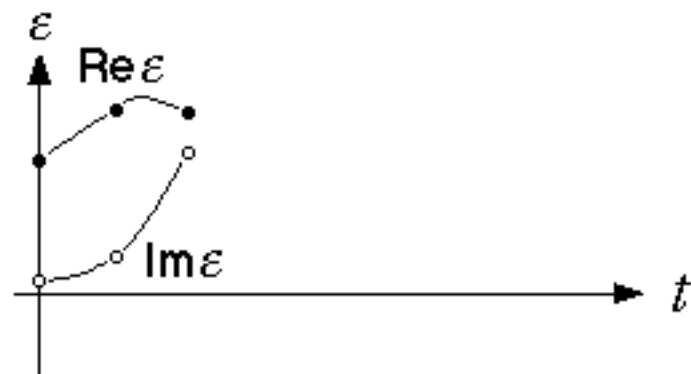
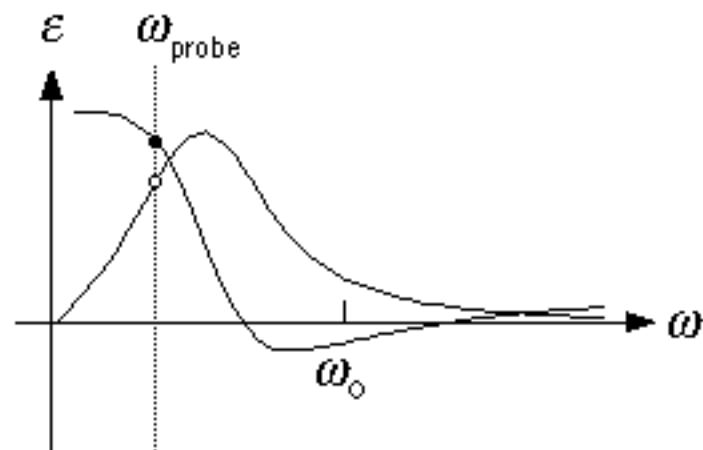
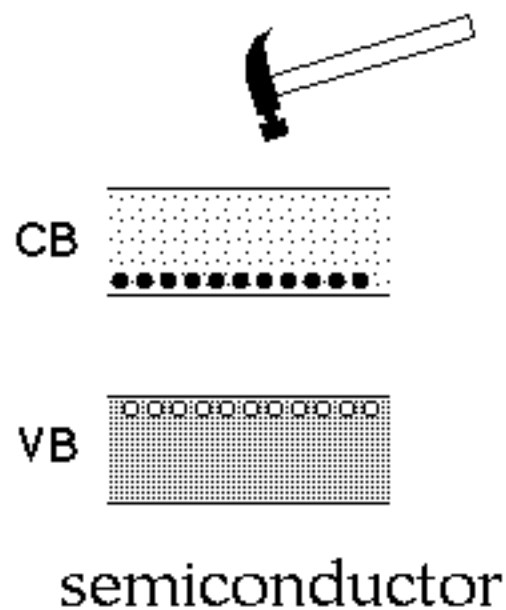

WHAT IS HAPPENING?

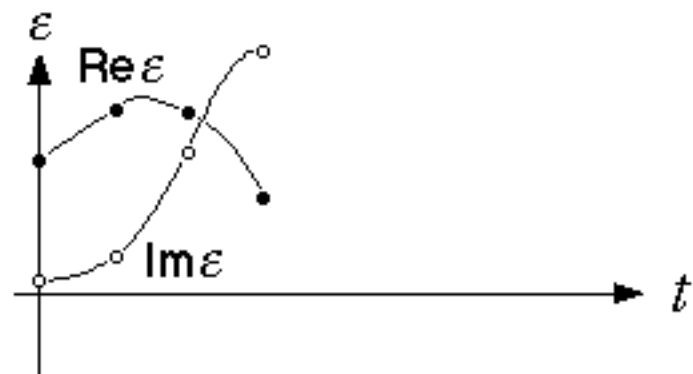
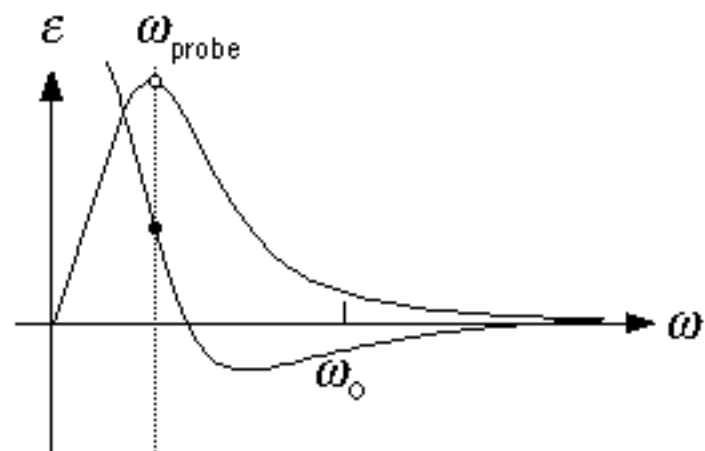
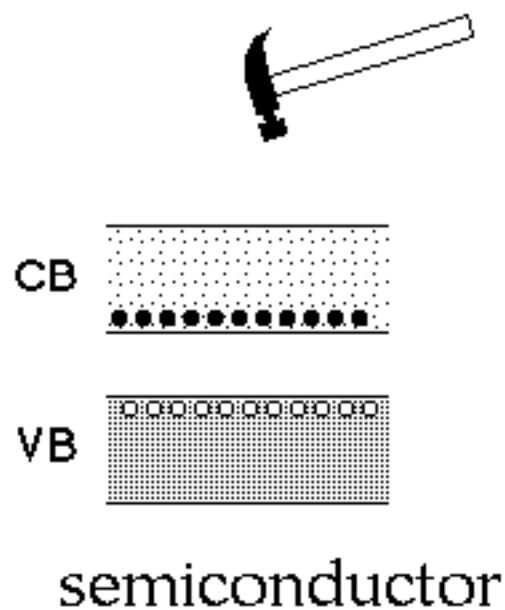

WHAT IS HAPPENING?

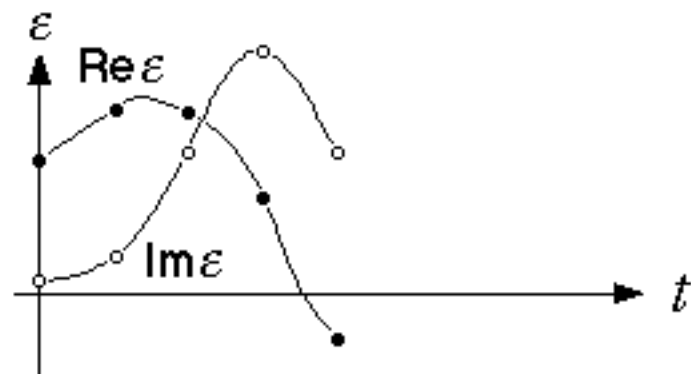
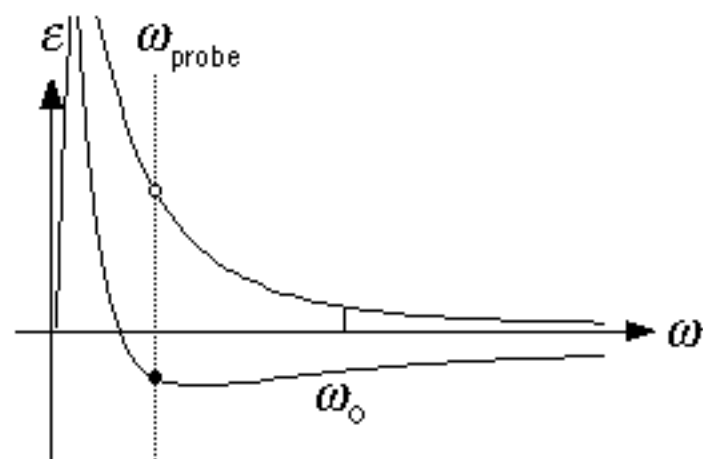
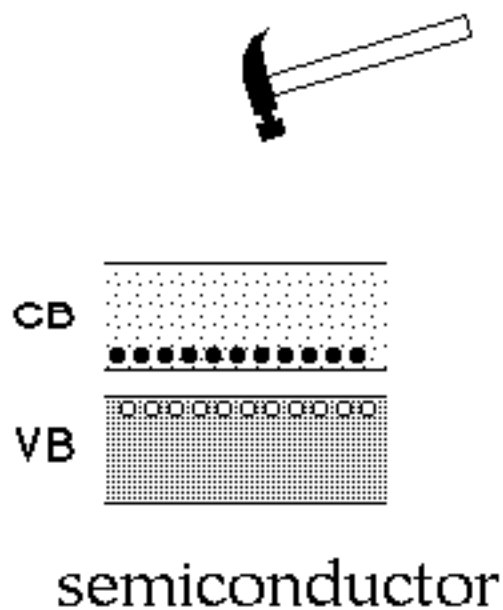

WHAT IS HAPPENING?

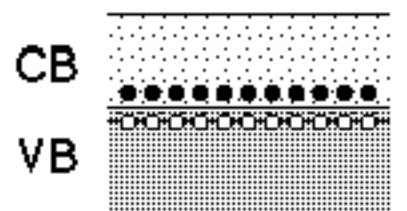
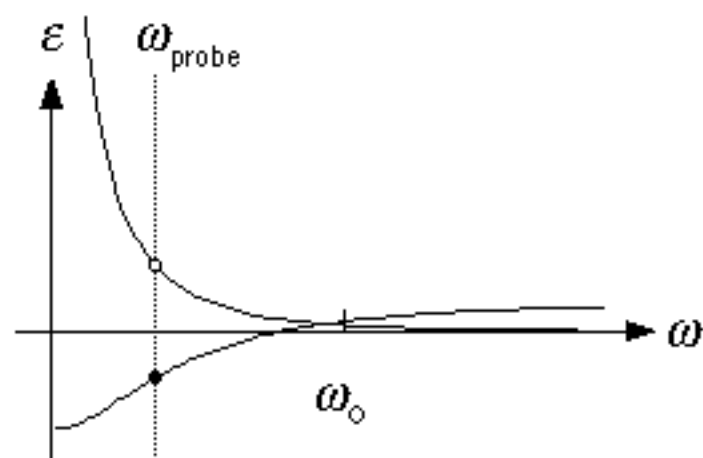
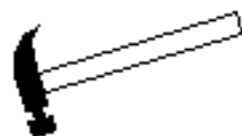

semimetal

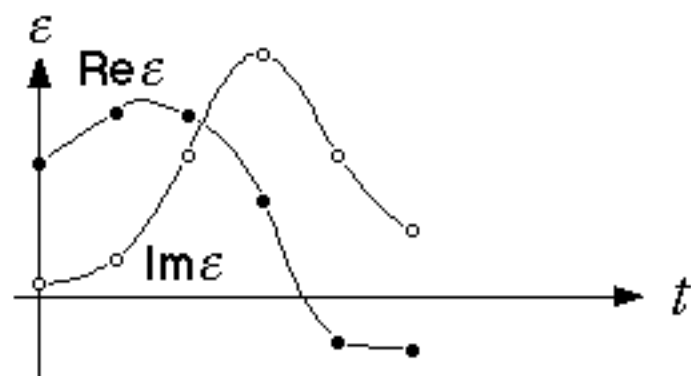

WHAT IS HAPPENING?

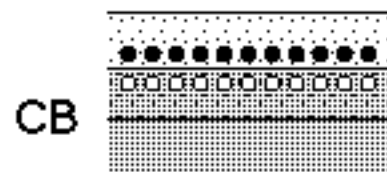
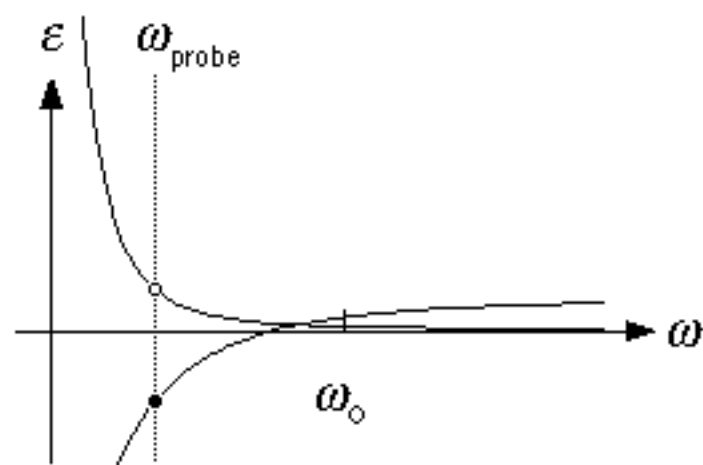
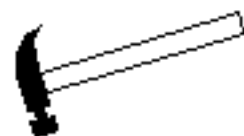

metal

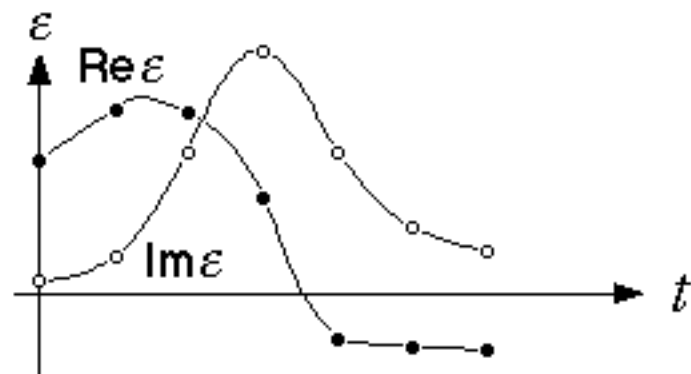

GaAs BANDSTRUCTURE

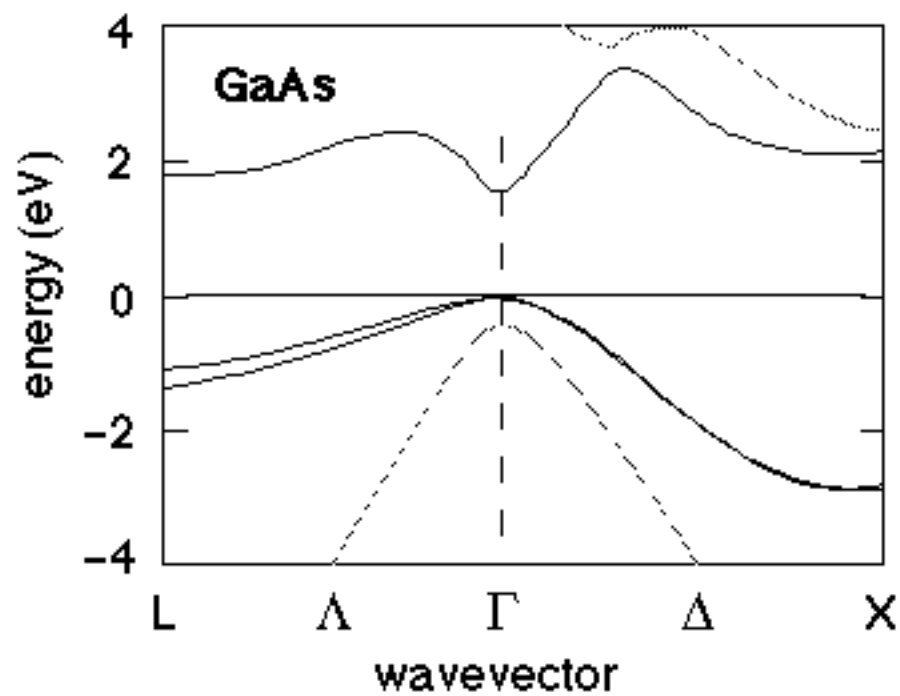

GaAs BANDSTRUCTURE

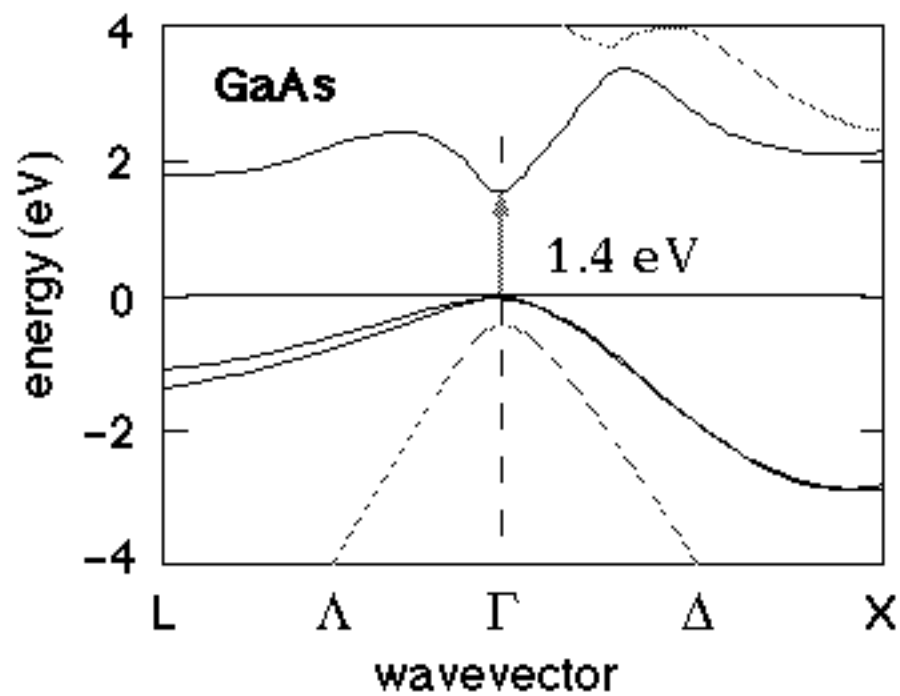

GaAs BANDSTRUCTURE

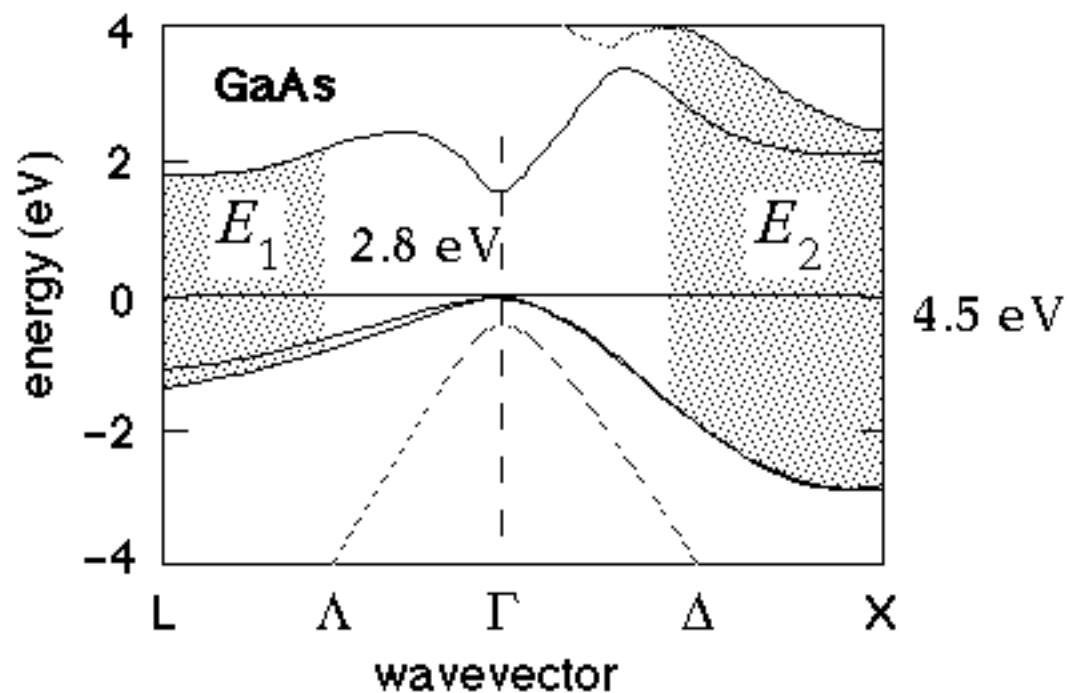

GaAs BANDSTRUCTURE

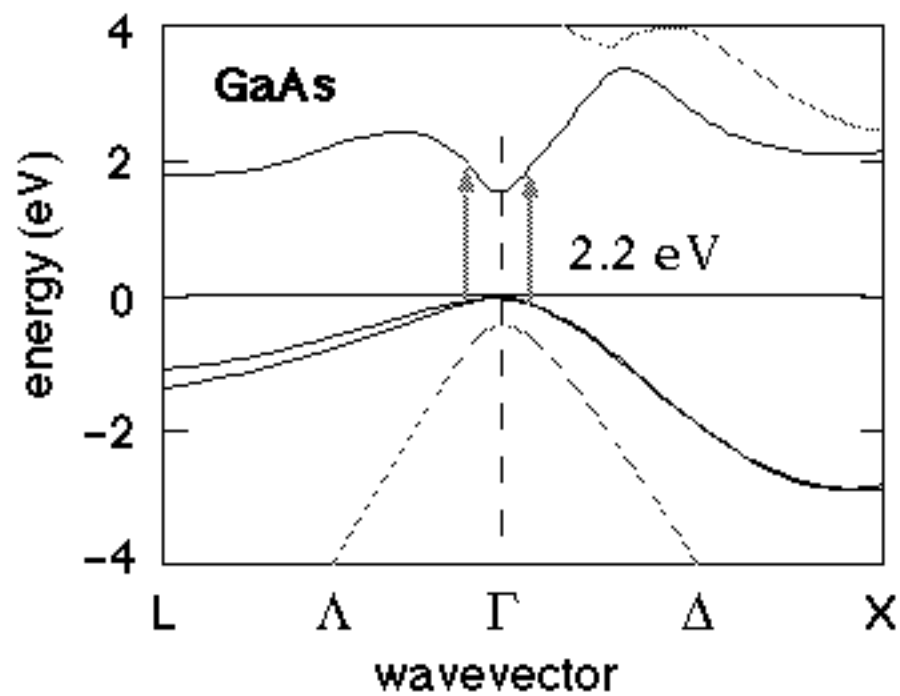

GaAs BANDSTRUCTURE

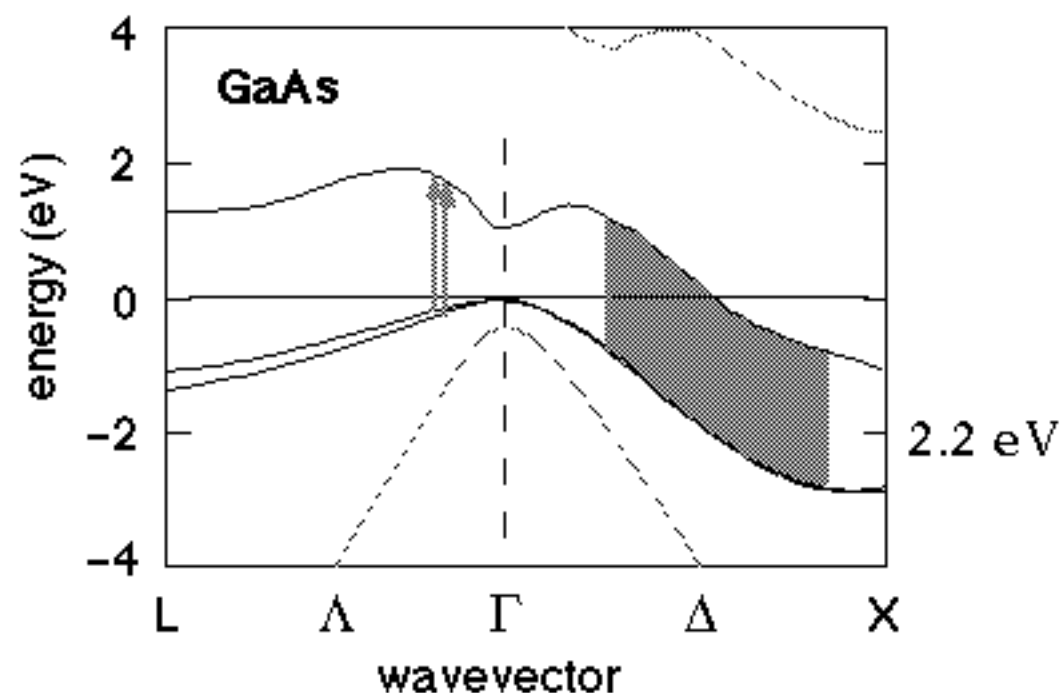

S. Froyen *et al.*, *Phys Rev. B* **28** (1983) 3258

D.H. Kim *et al.*, *Sol. State. Comm.* **89** (1994) 119



GaAs BANDSTRUCTURE

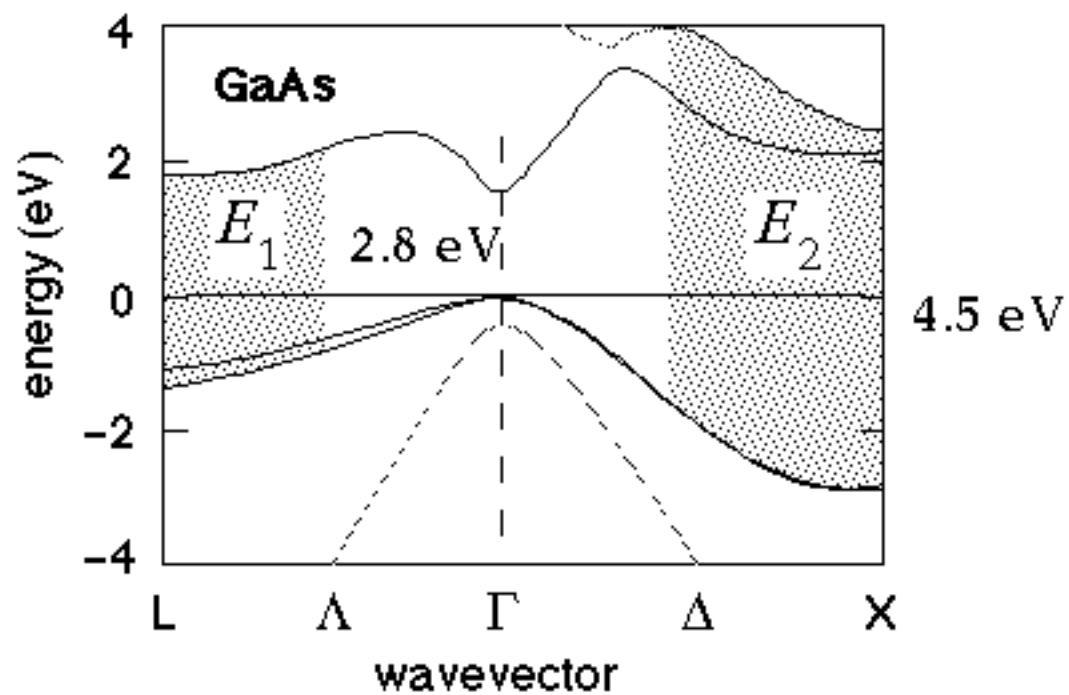

GaAs DIELECTRIC FUNCTION

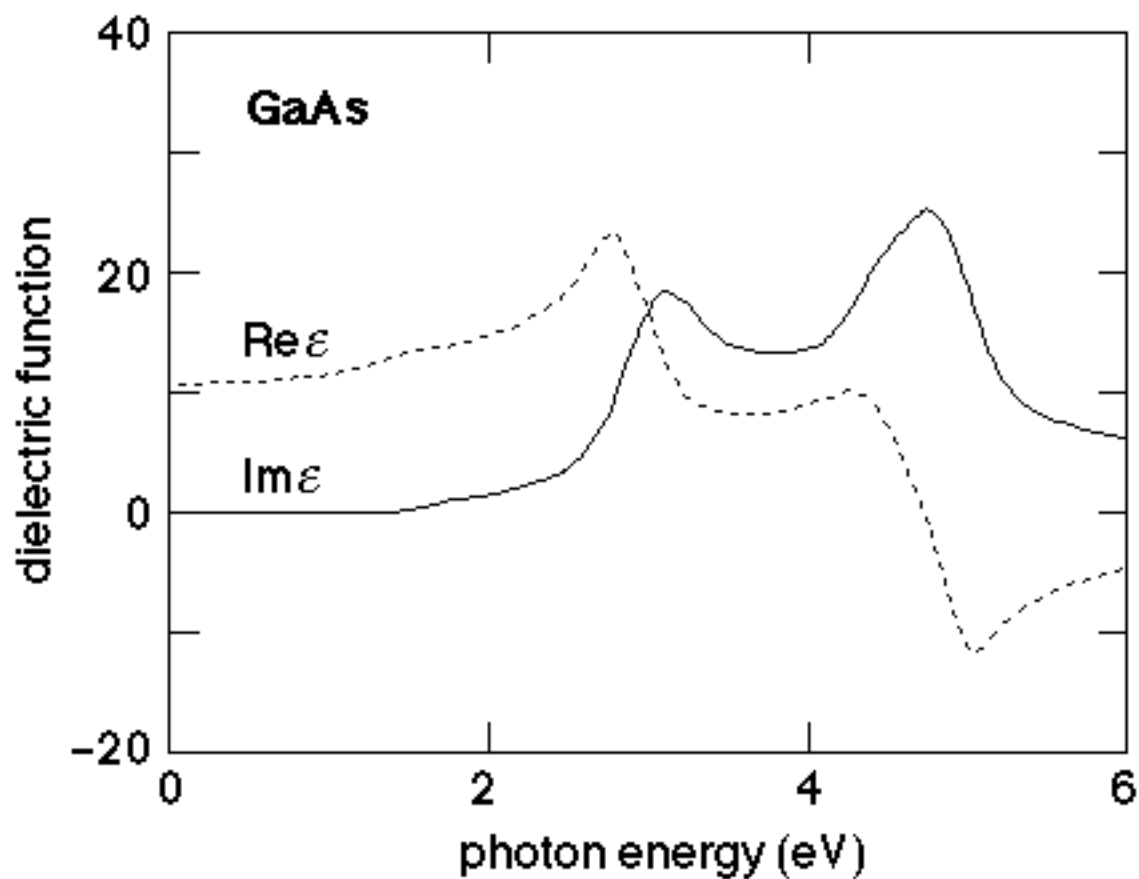

GaAs DIELECTRIC FUNCTION

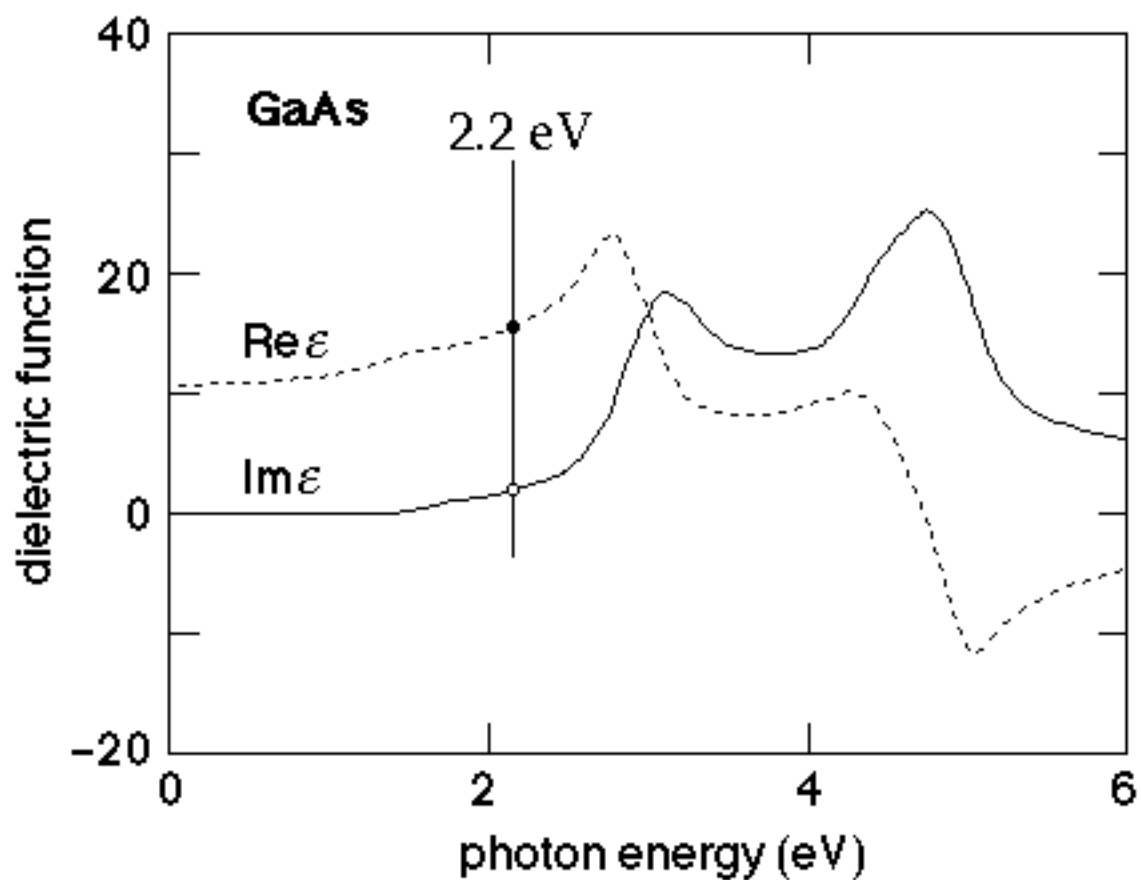

GaAs DIELECTRIC FUNCTION

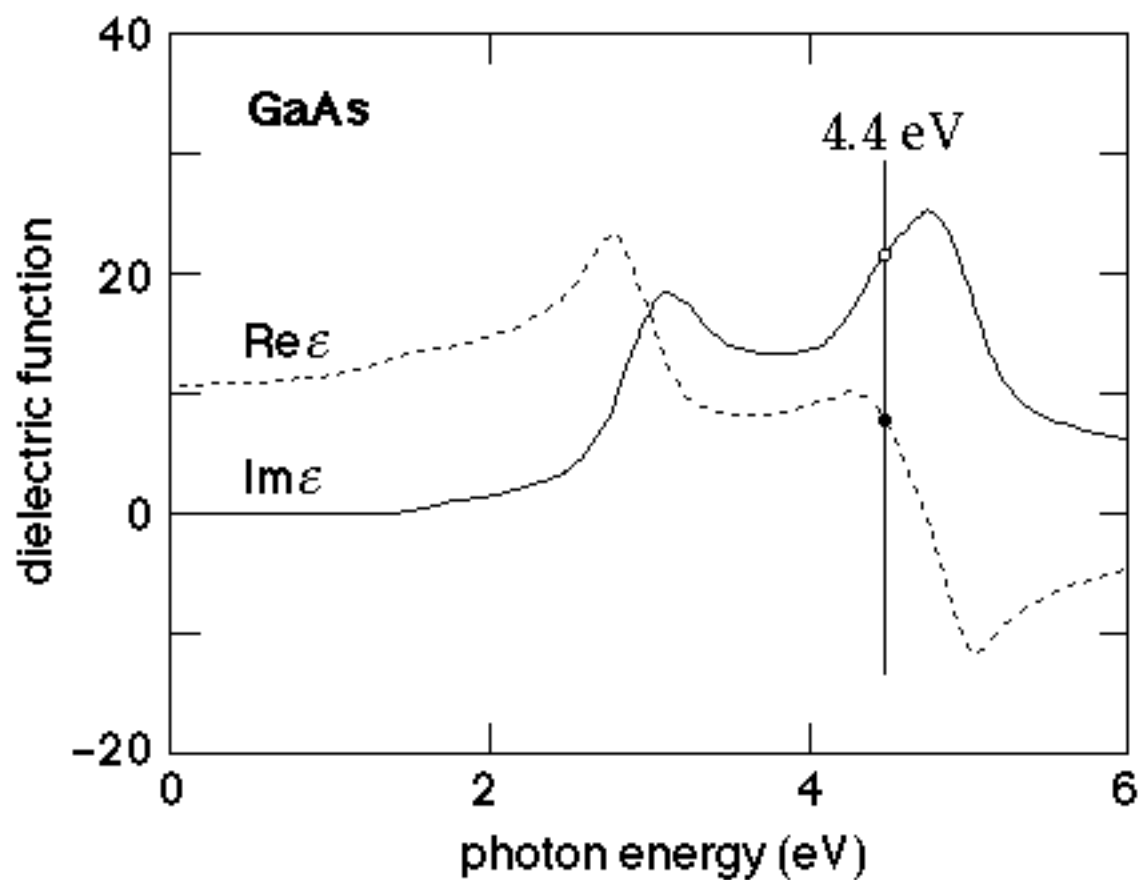

FLUENCE DEPENDENCE

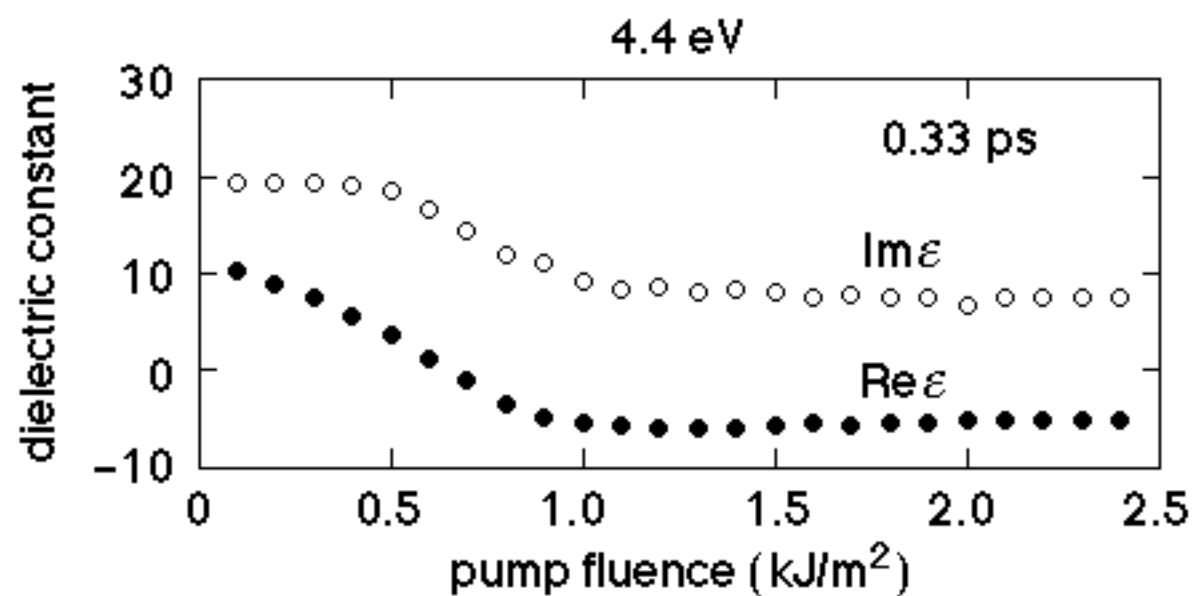

FLUENCE DEPENDENCE

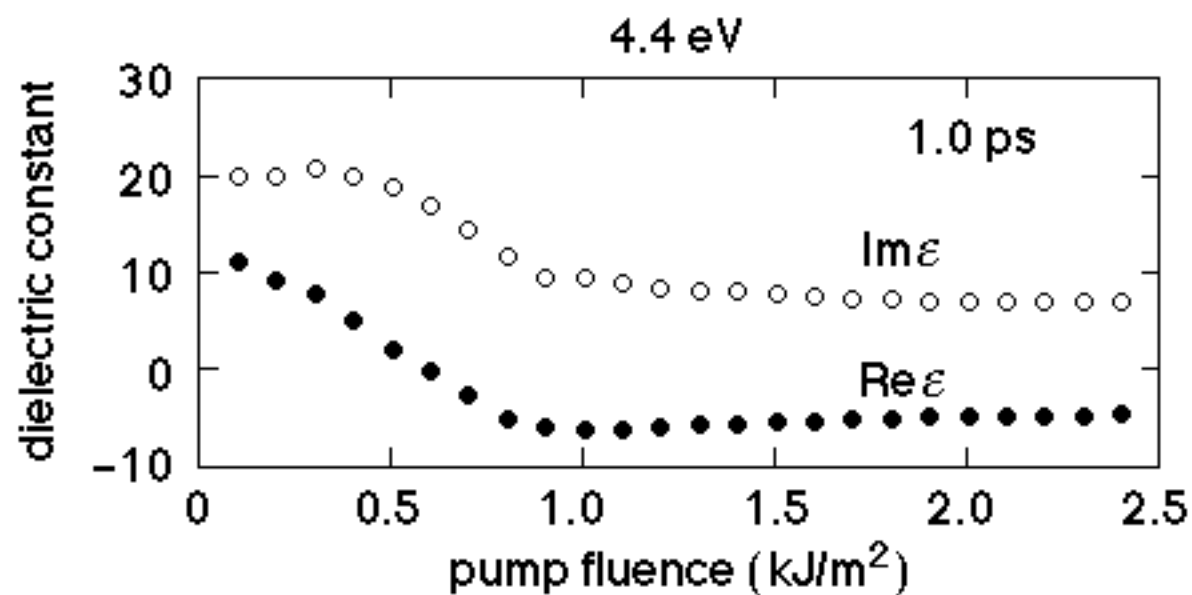

FLUENCE DEPENDENCE

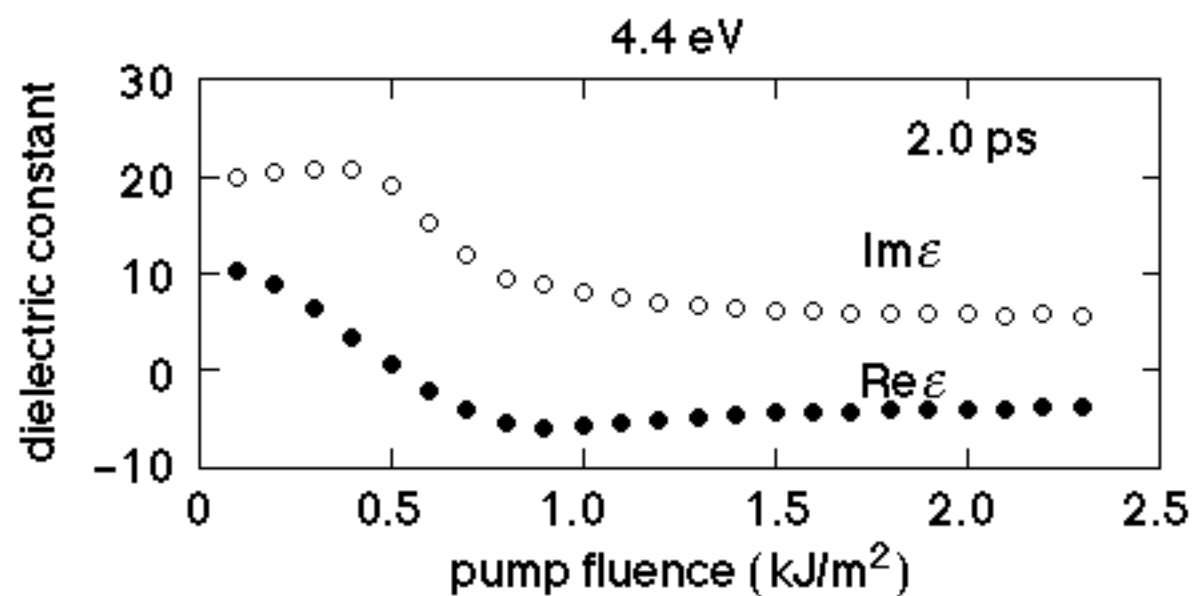

FLUENCE DEPENDENCE

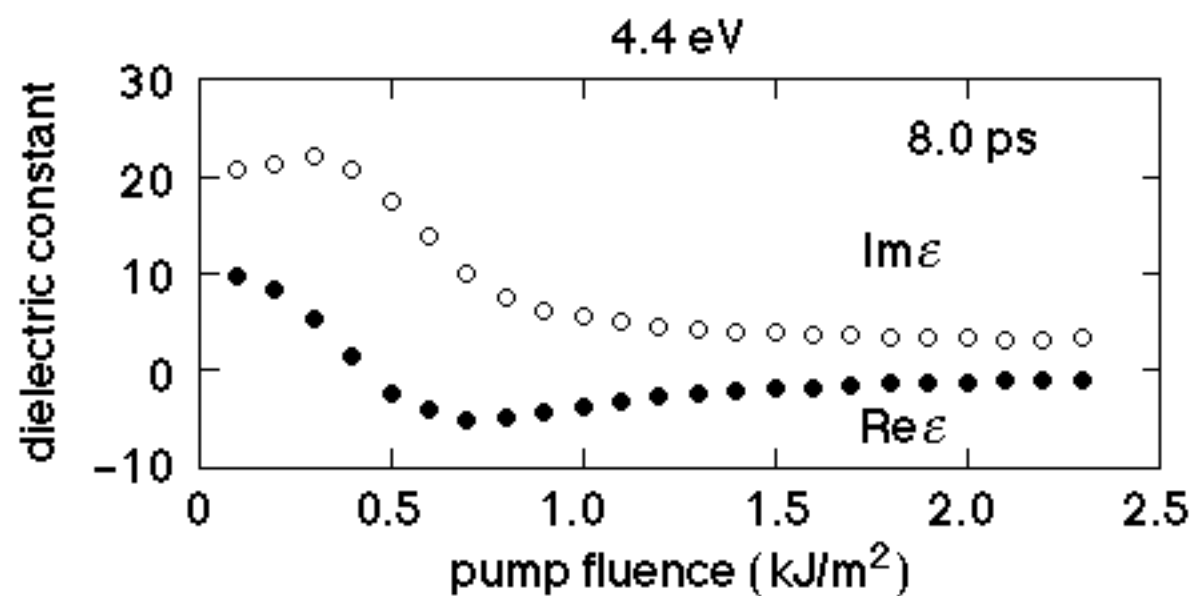

SUMMARY

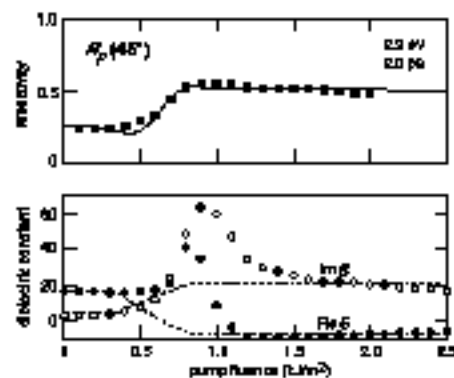

single-angle reflectivity not a good indicator of what happens

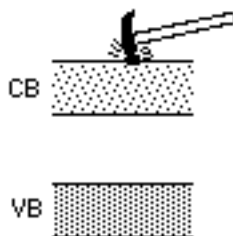

laser pulse causes bandgap collapse



CAUSE OF COLLAPSE

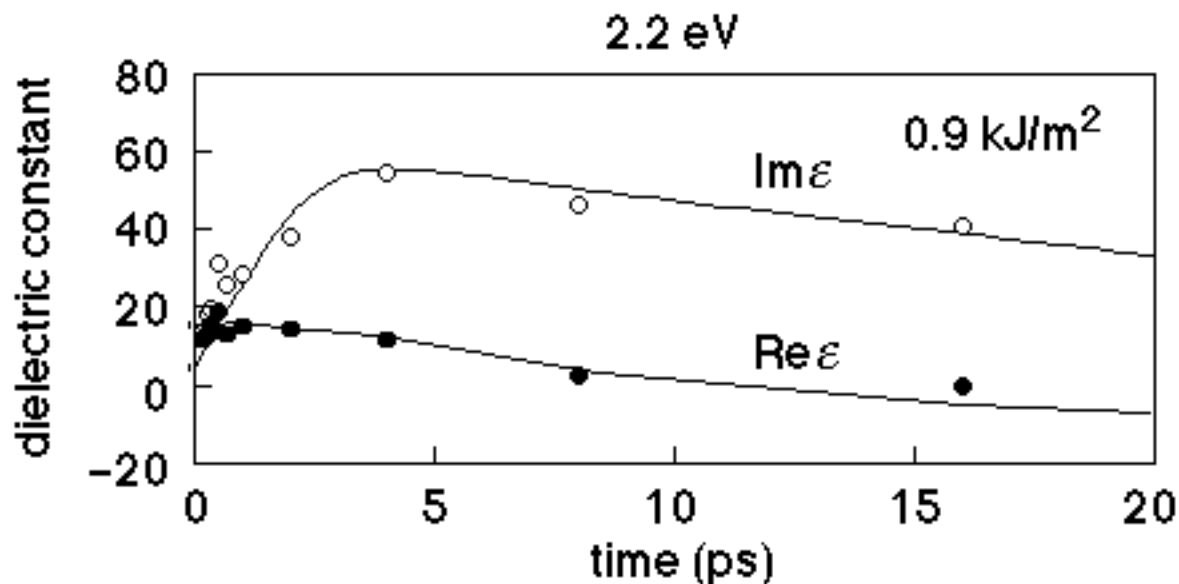

slow rise time → collapse cannot be caused by electronic effects alone

structural change?



Field strength at second harmonic:

$$E_r(2\omega) = -4\pi P^{(2)}(2\omega) g[\epsilon(\omega), \epsilon(2\omega), \theta_i]$$



FEMTOSECOND WORK

Field strength at second harmonic:

$$E_r(2\omega) = -4\pi P^{(2)}(2\omega) g[\epsilon(\omega), \epsilon(2\omega), \theta_i]$$

where:

$$P^{(2)}(2\omega) = 2\chi^{(2)} E_i^2(\omega) f[\epsilon(\omega), \theta_i]$$

so:



FEMTOSECOND WORK

Field strength at second harmonic:

$$E_r(2\omega) = -4\pi P^{(2)}(2\omega) g[\epsilon(\omega), \epsilon(2\omega), \theta_i]$$

where:

$$P^{(2)}(2\omega) = 2\chi^{(2)} E_i^2(\omega) f[\epsilon(\omega), \theta_i]$$

so:

$$|\chi^{(2)}|^2 = \frac{E_r^2(2\omega)}{E_i^2(\omega) G[\epsilon(\omega), \epsilon(2\omega), \theta_i]}$$



SECOND HARMONIC DATA

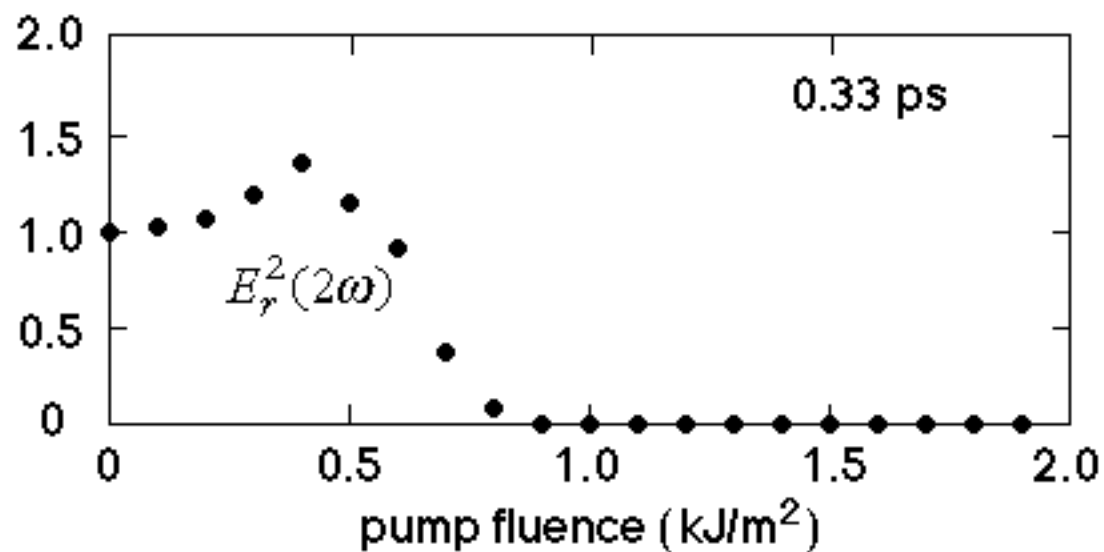

SECOND HARMONIC DATA

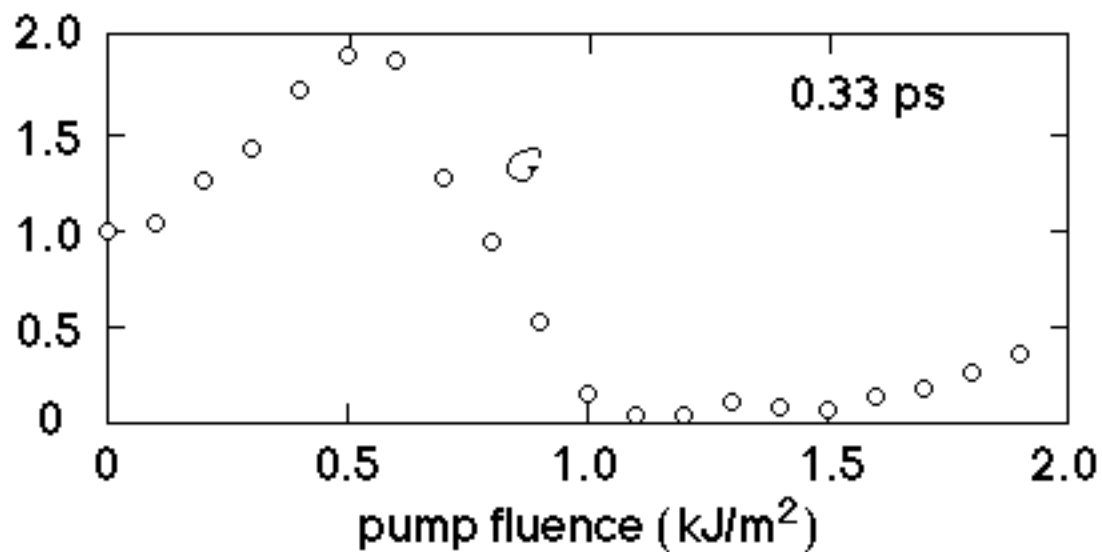

SECOND HARMONIC DATA

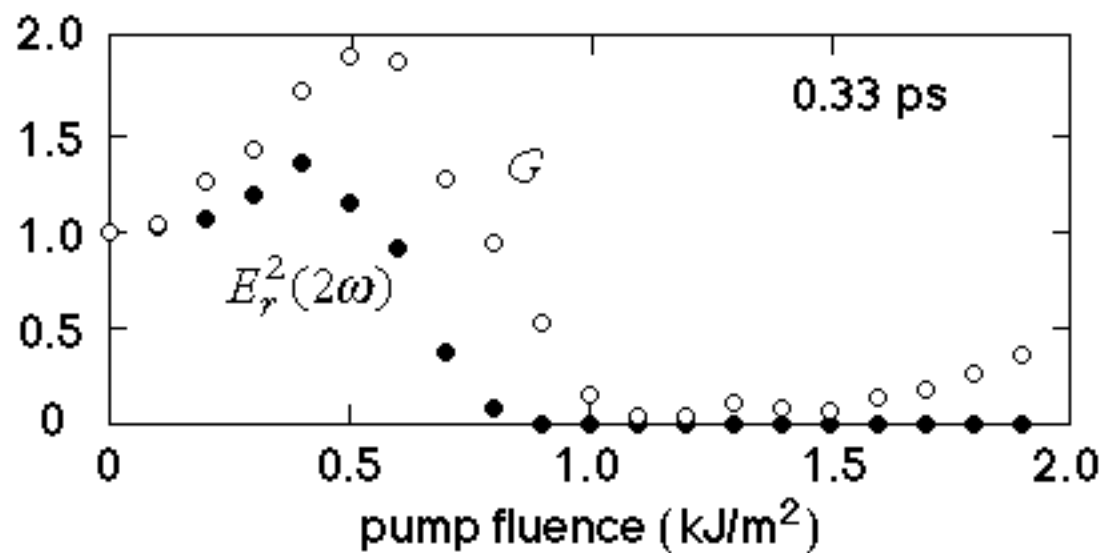

SECOND HARMONIC DATA

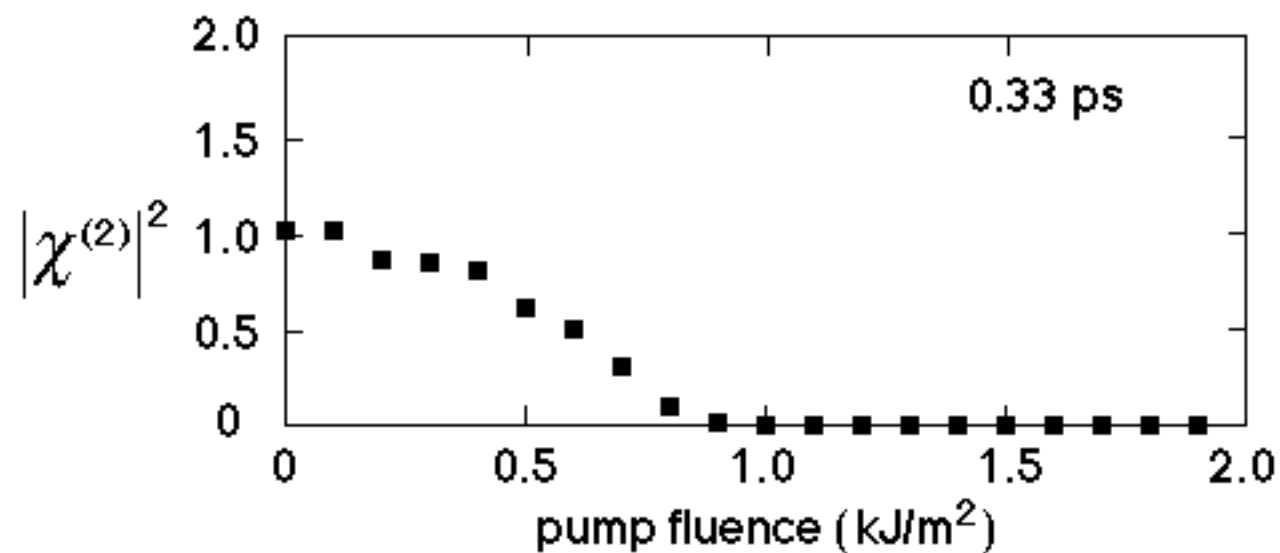

SECOND HARMONIC DATA

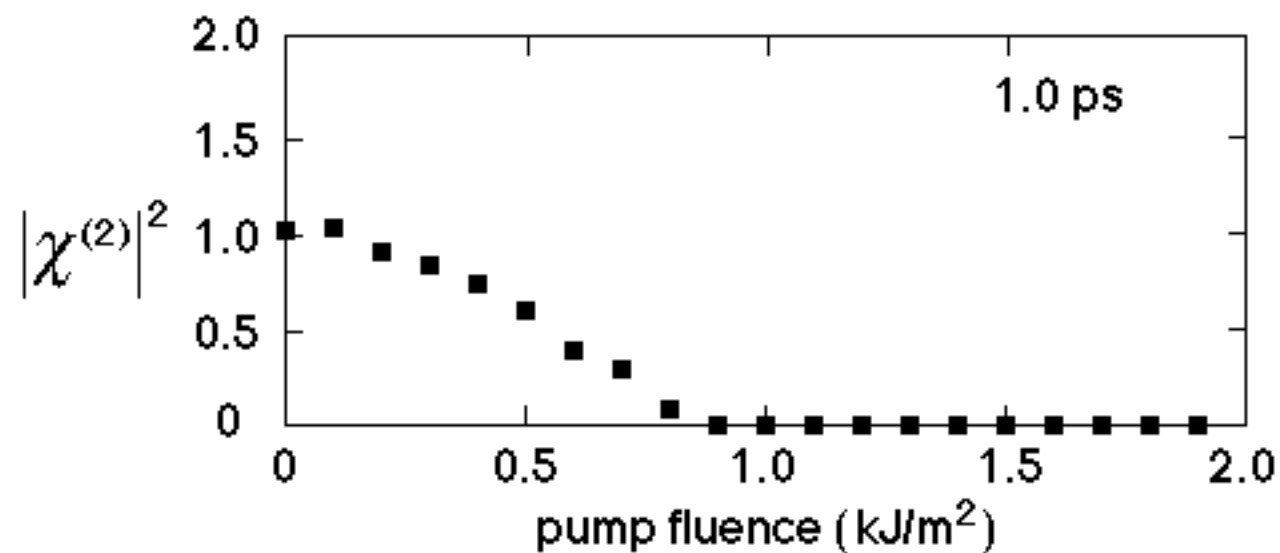

SECOND HARMONIC DATA

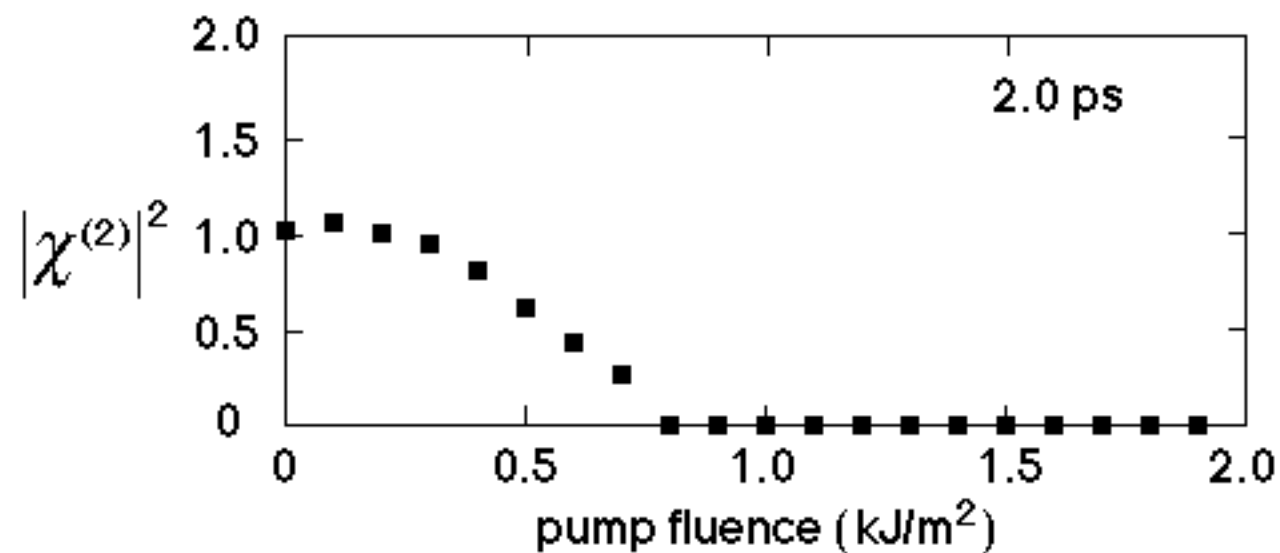

SECOND HARMONIC DATA

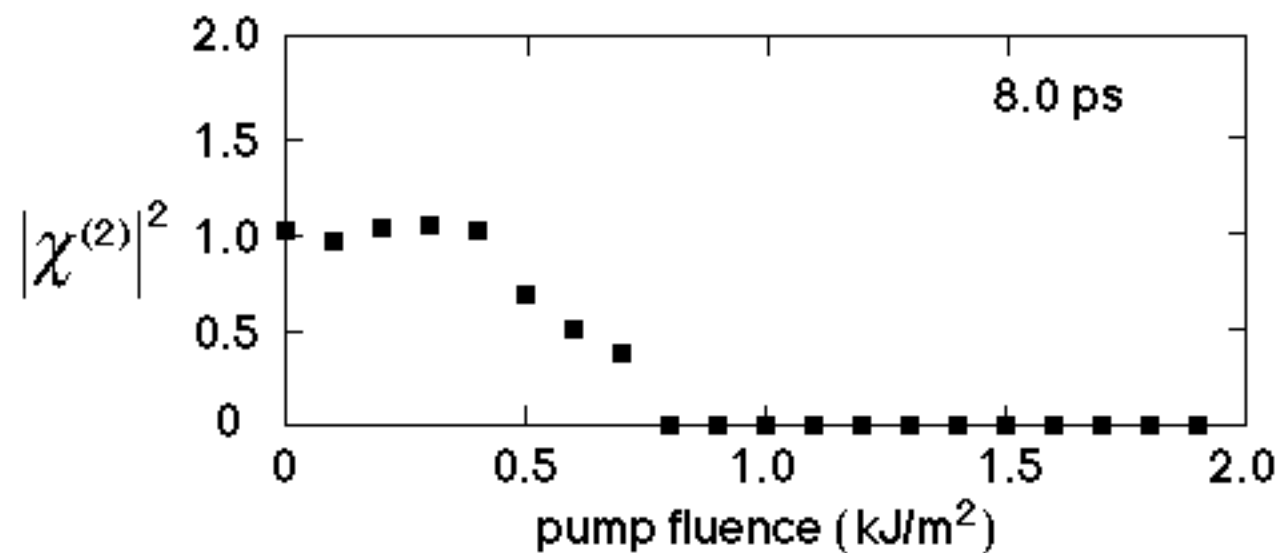

SECOND HARMONIC DATA

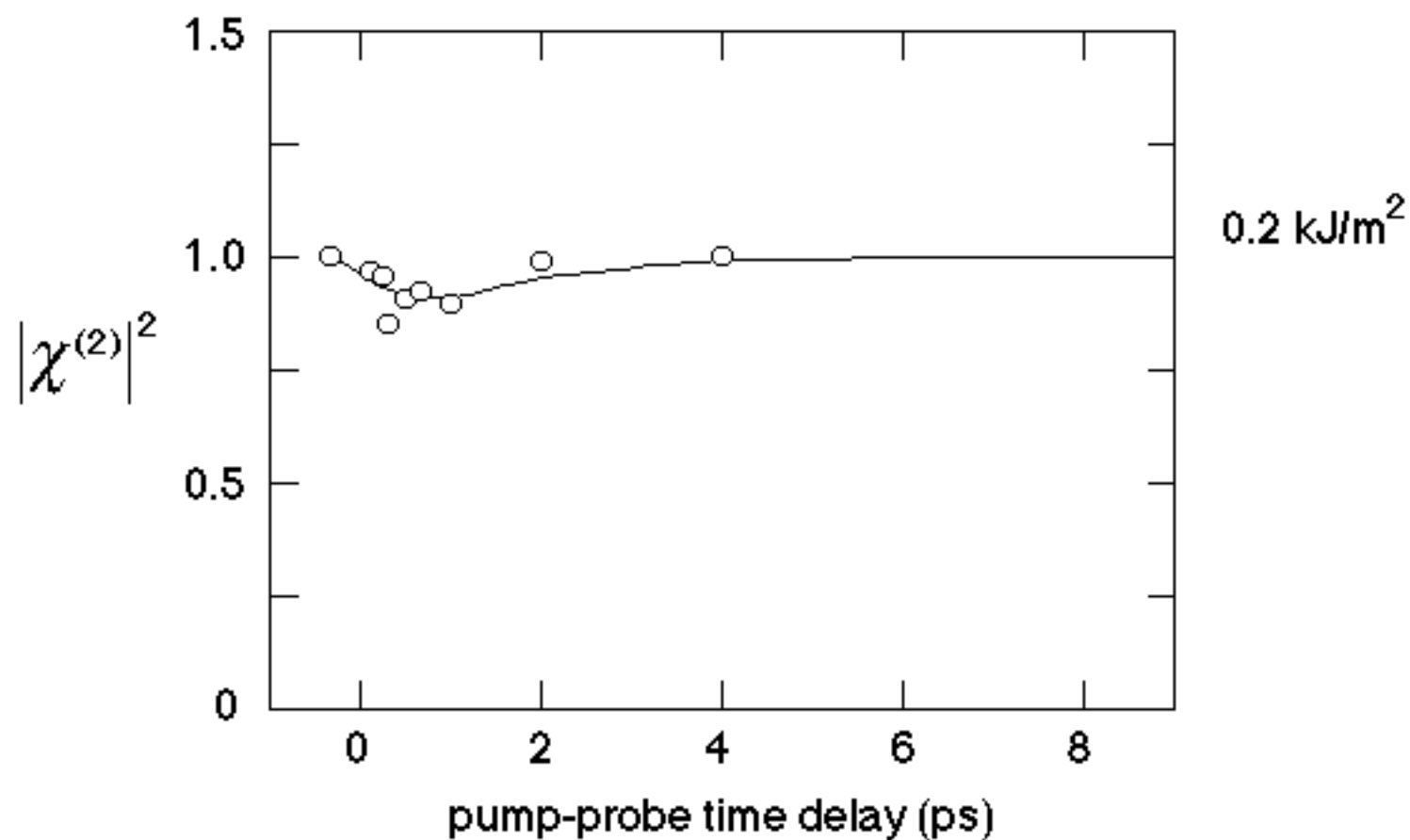

SECOND HARMONIC DATA

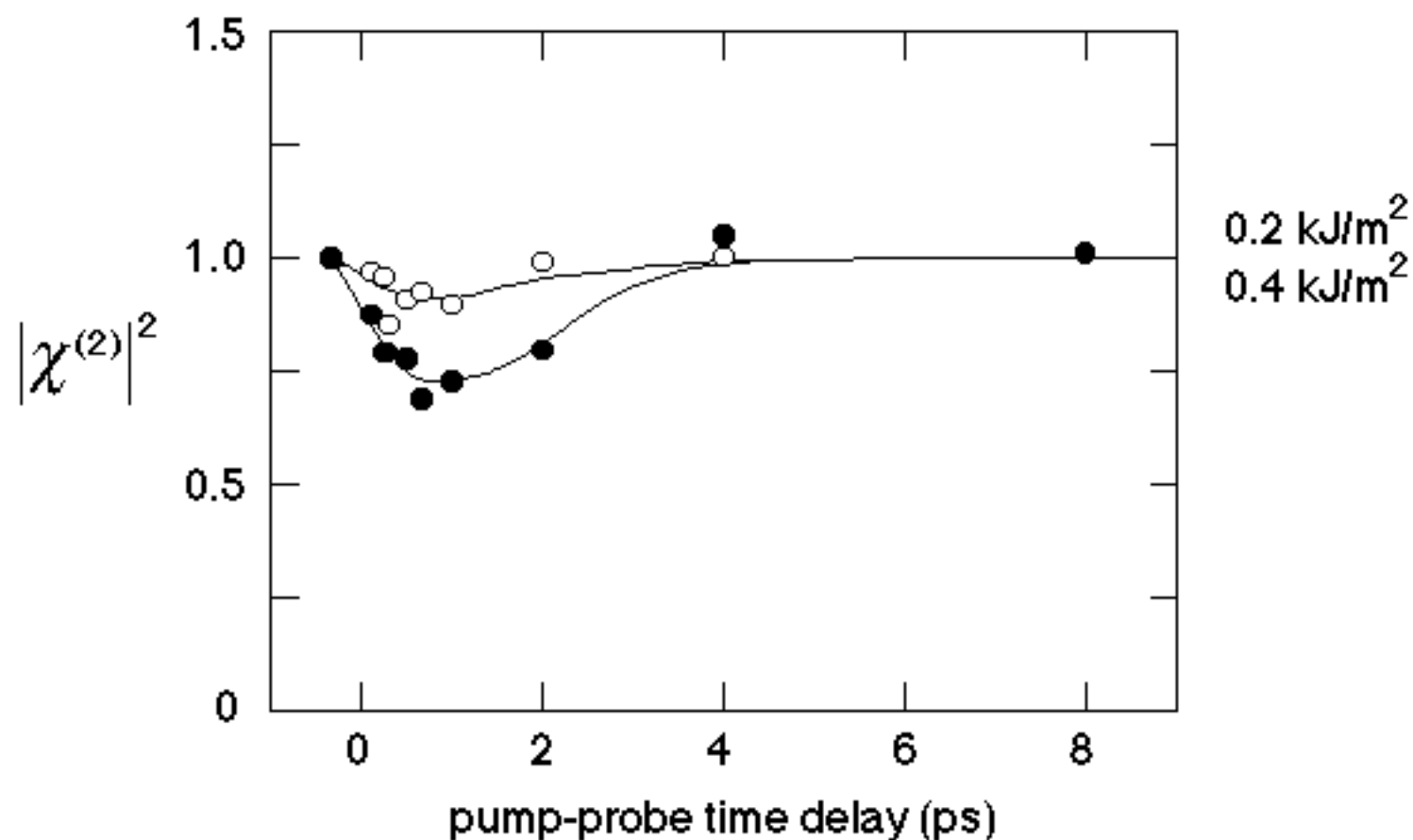

SECOND HARMONIC DATA

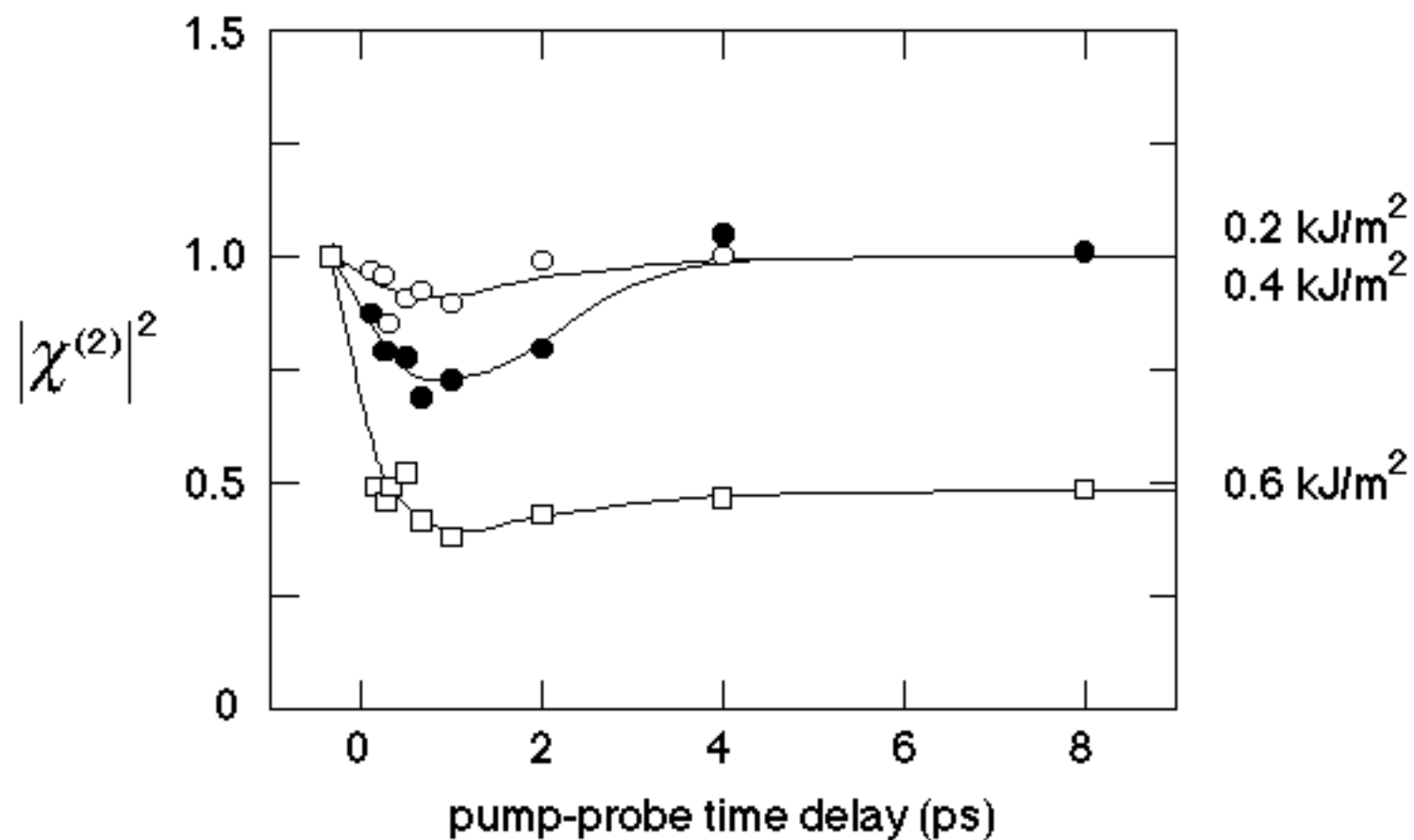

SECOND HARMONIC DATA

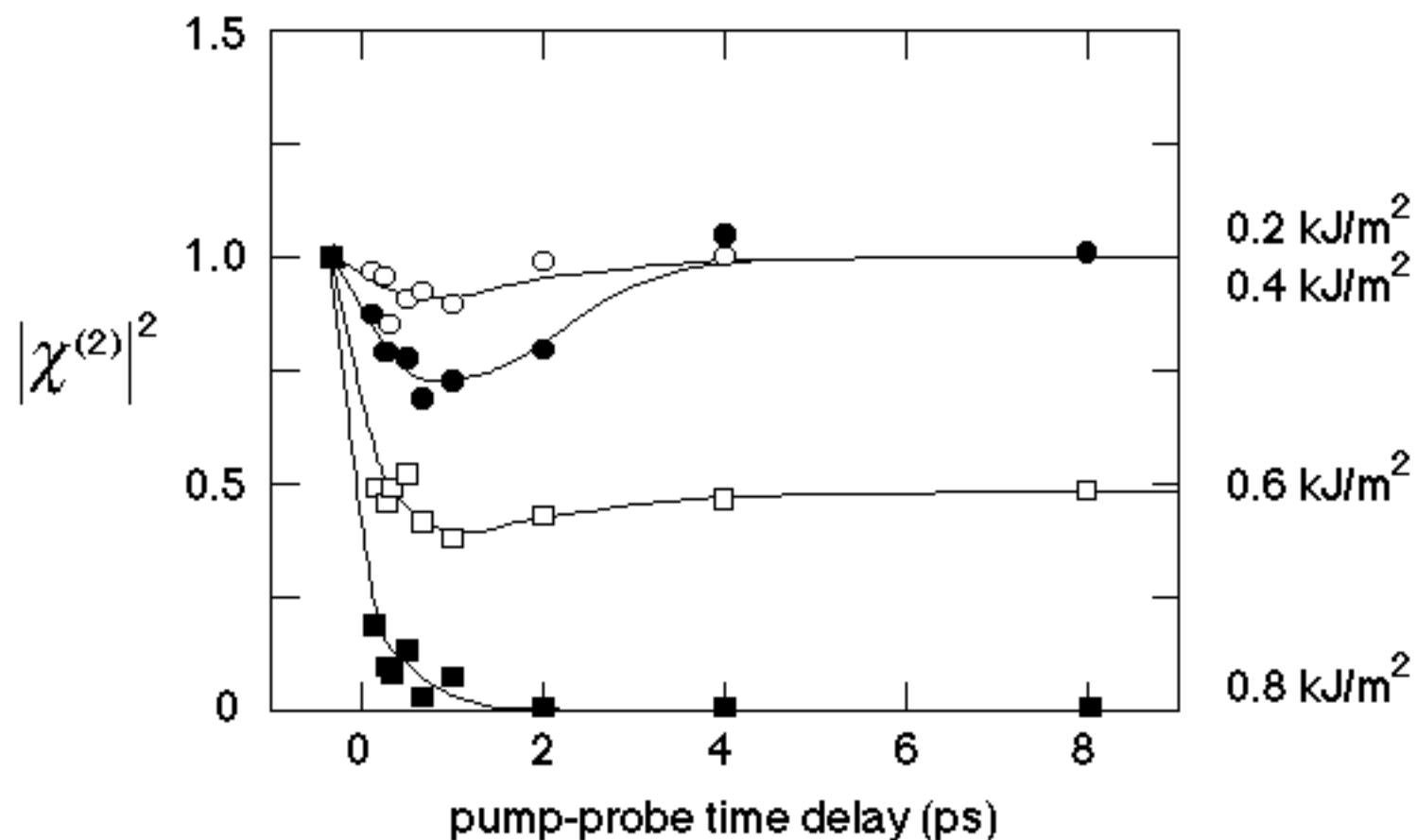

SECOND HARMONIC DATA

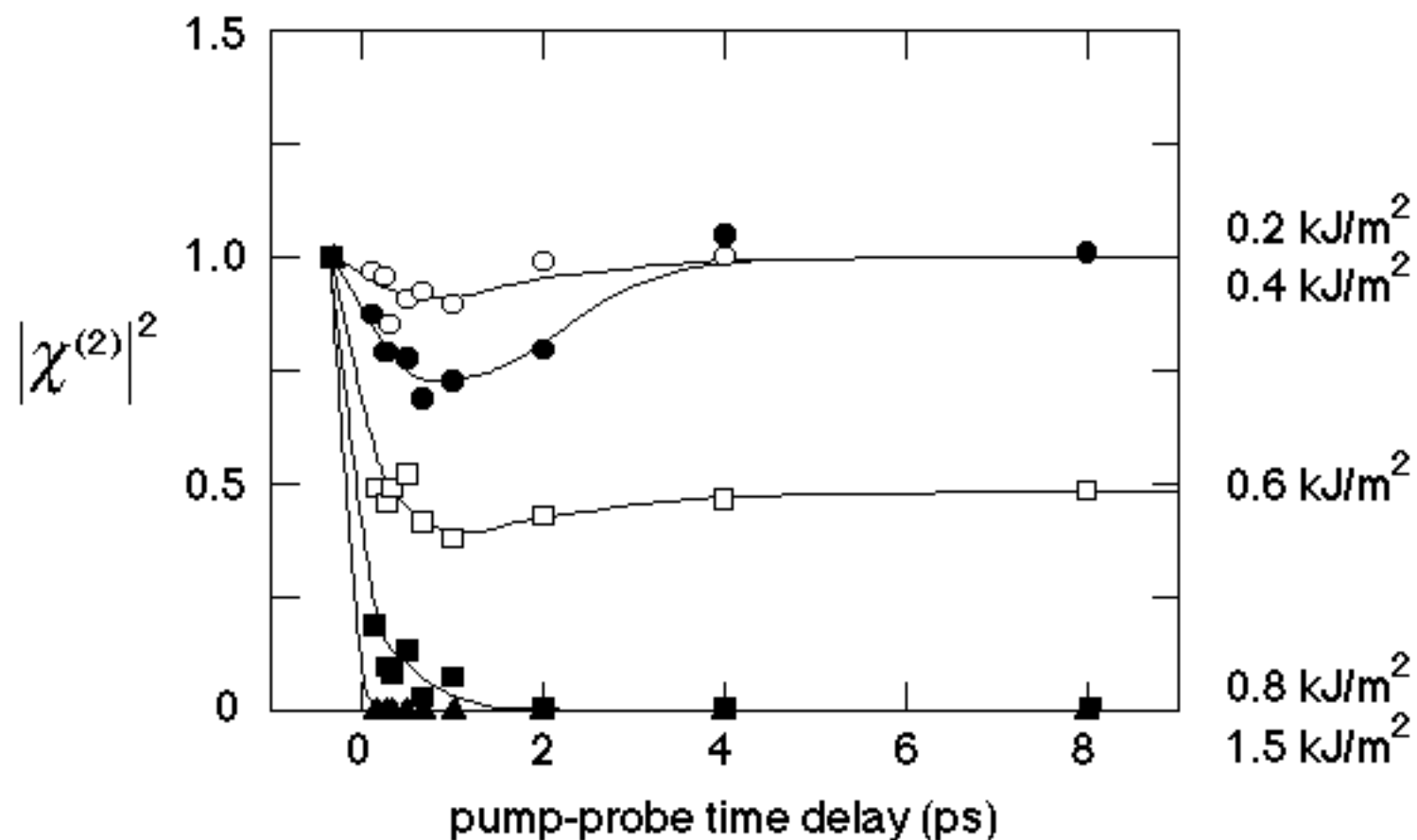

EFFECT OF CHANGES IN ϵ

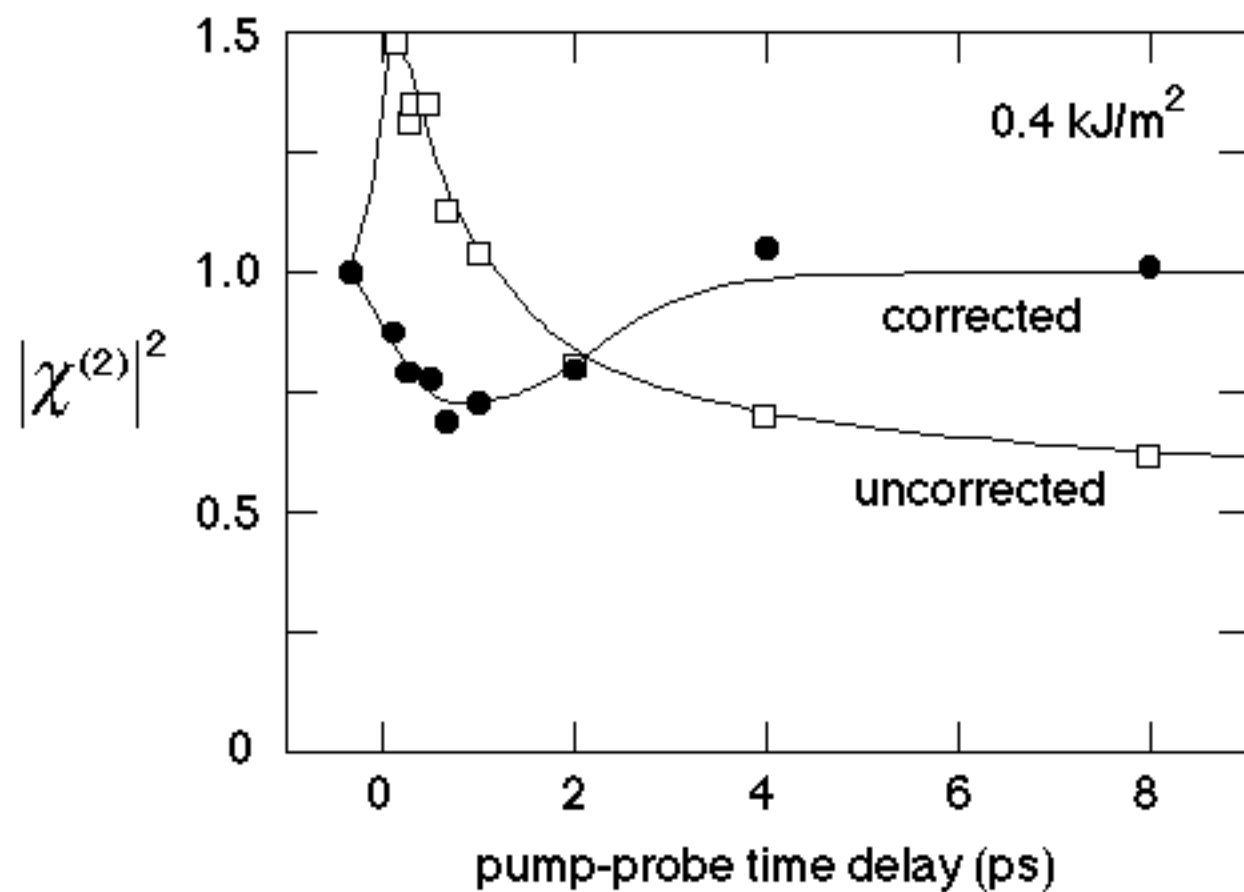

FEMTOSECOND WORK

- $\chi^{(2)}$ sensitive to loss of long-range order
- long-range order disappears even below threshold
- structural change due to destabilization of covalent bonds
- time-scale for structural change reasonable (10% of bond length in 1 ps requires 25 m/s)



- ① Background
- ② Single frequency work
- ③ Broadband work



BROADBAND PROBE

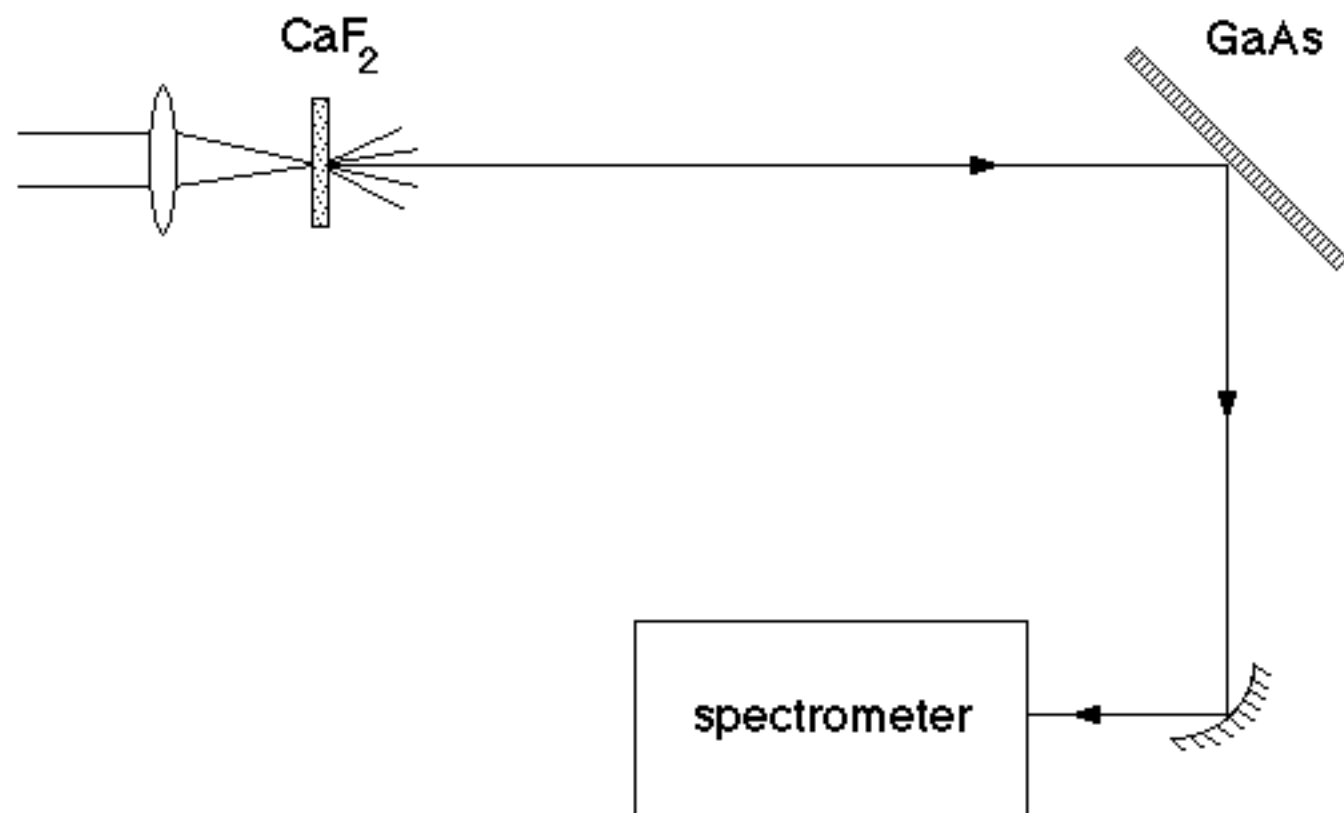

BROADBAND PROBE

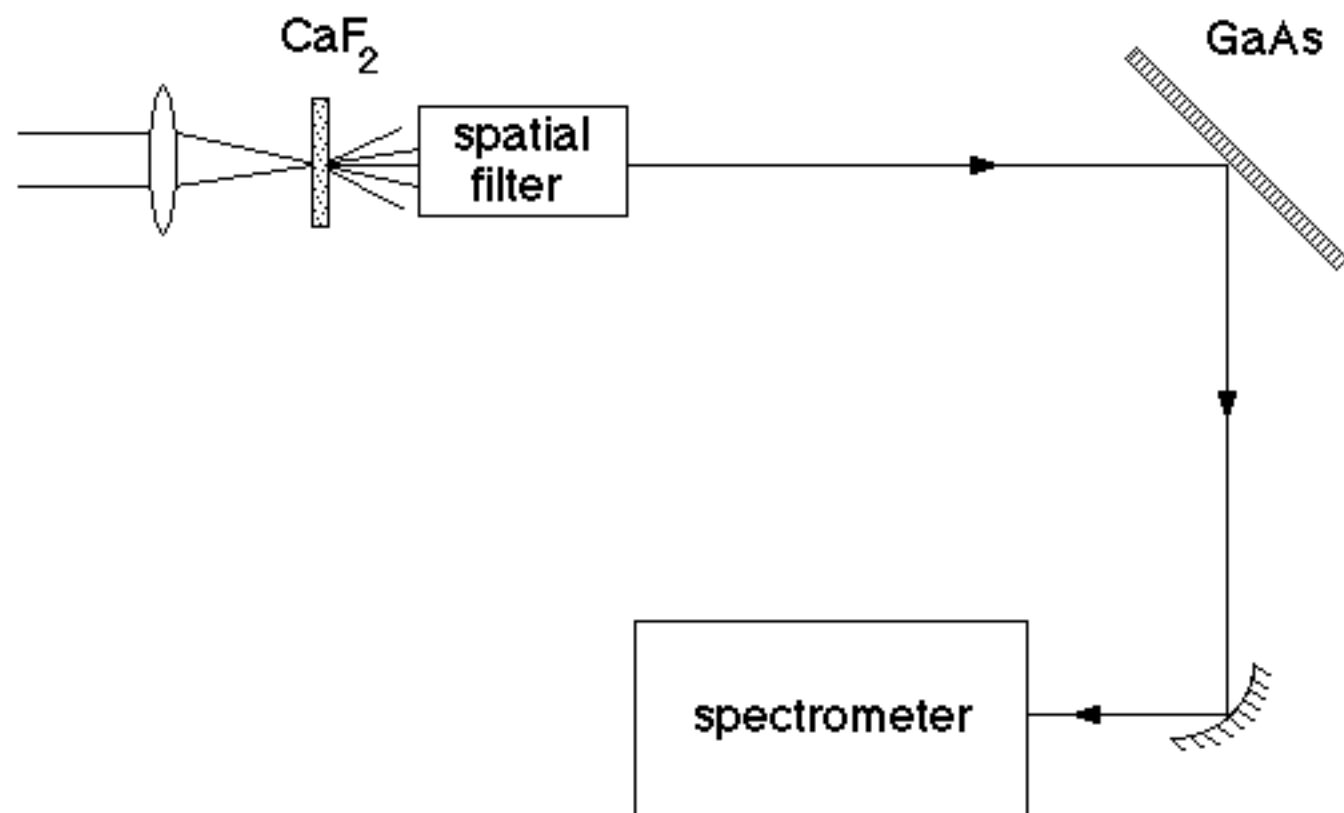

BROADBAND PROBE

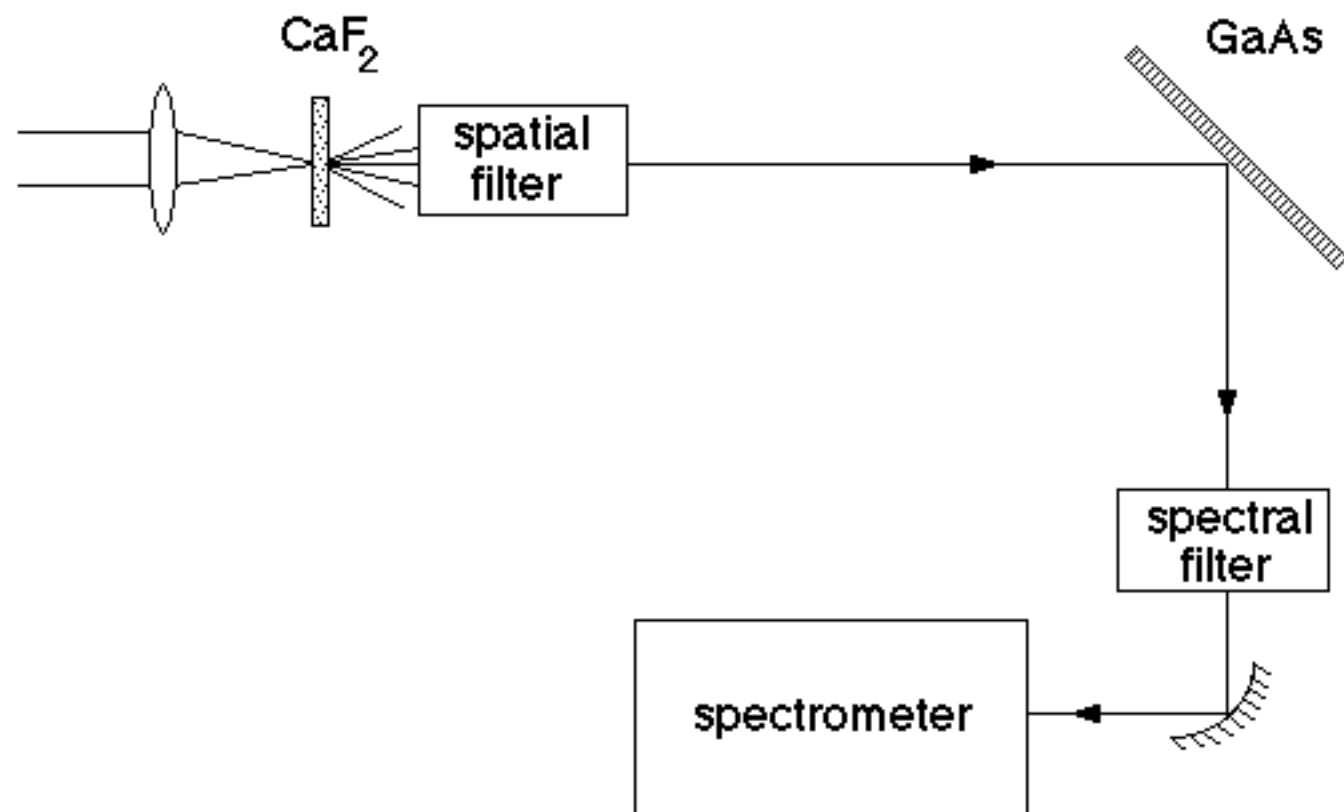

BROADBAND PROBE

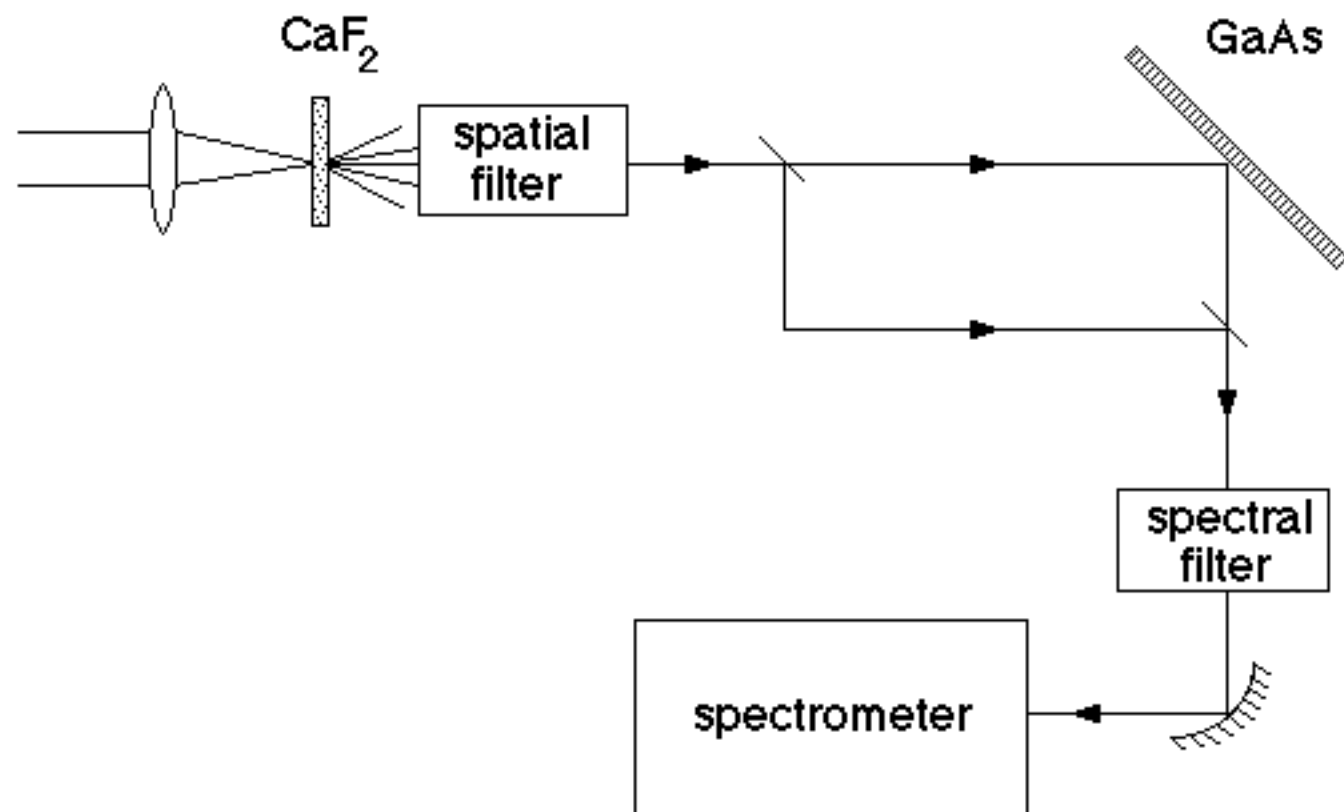

WHITE LIGHT SPECTRUM

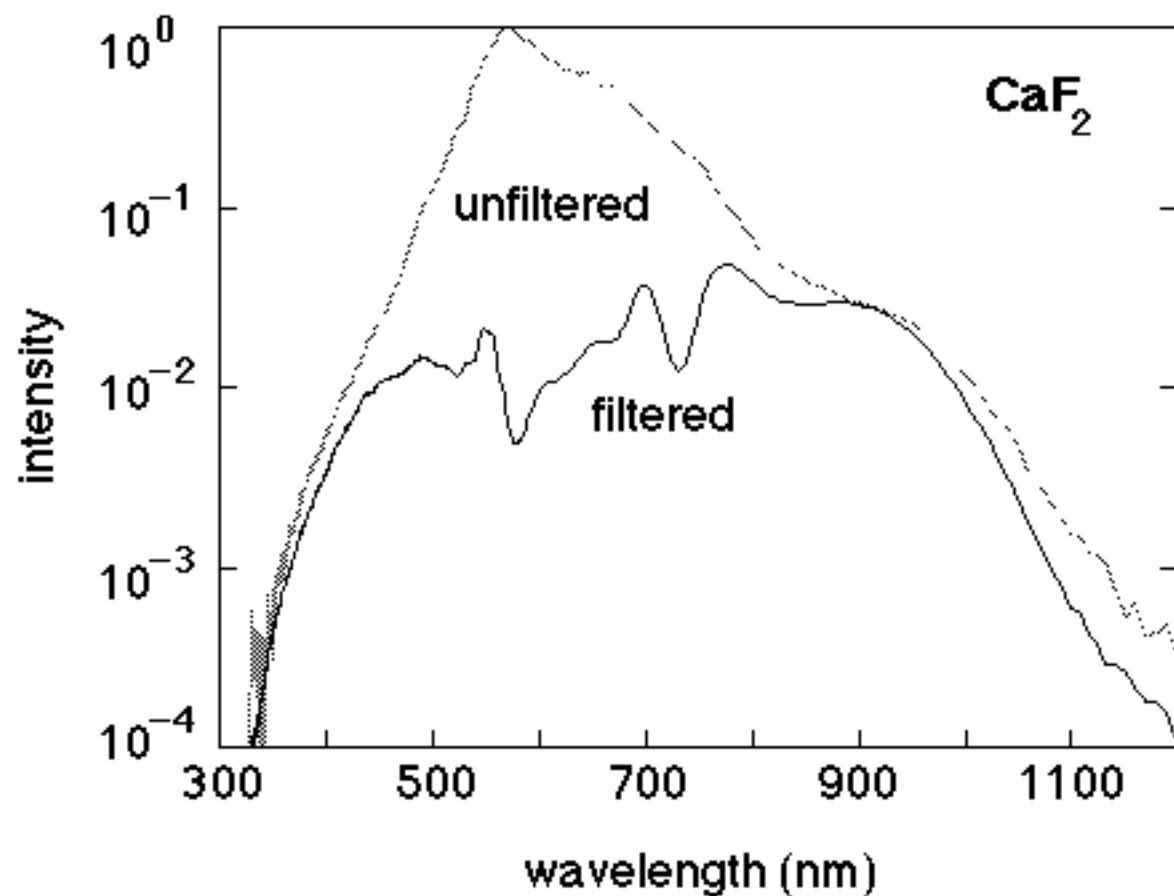

BROADBAND DATA

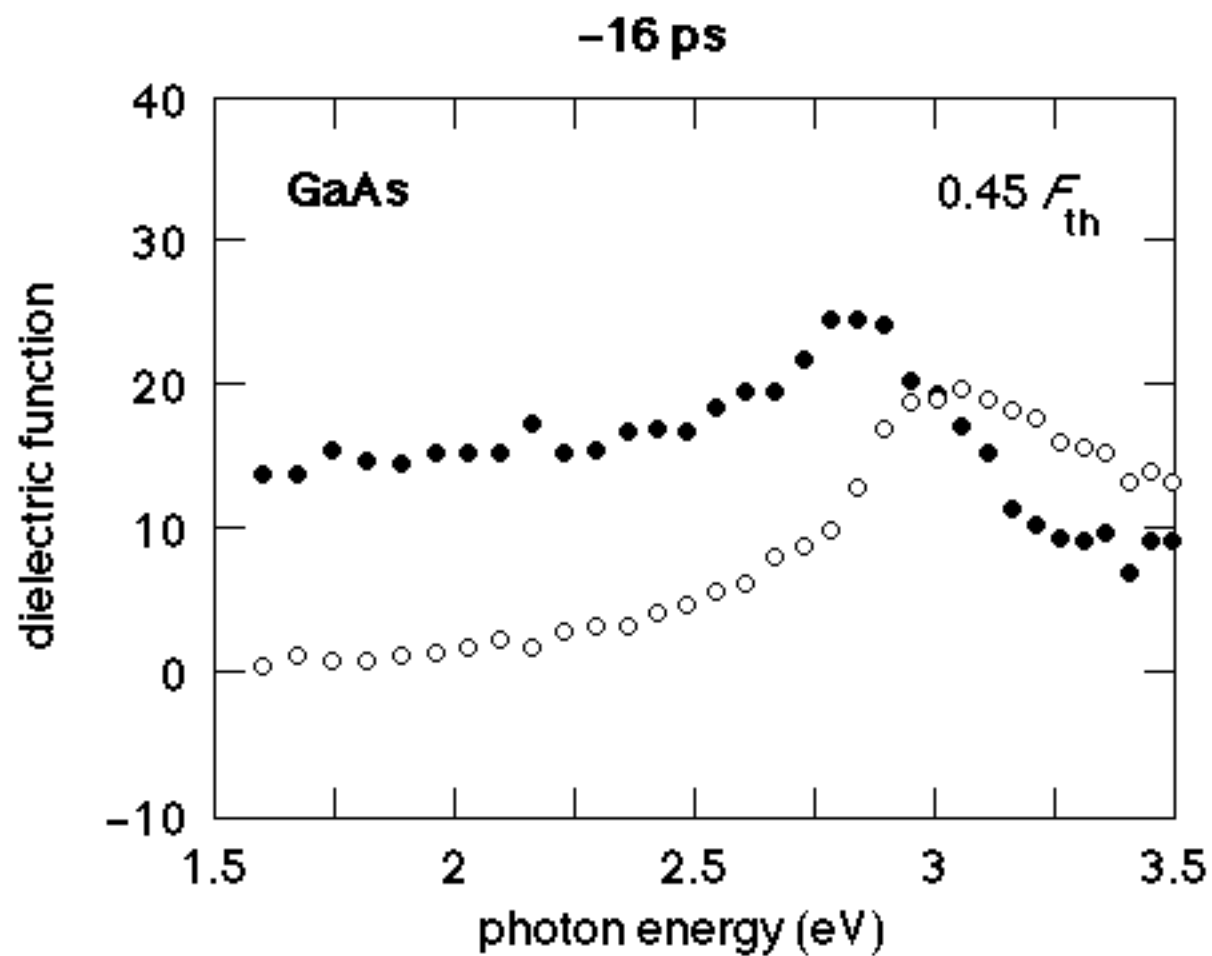

BROADBAND DATA

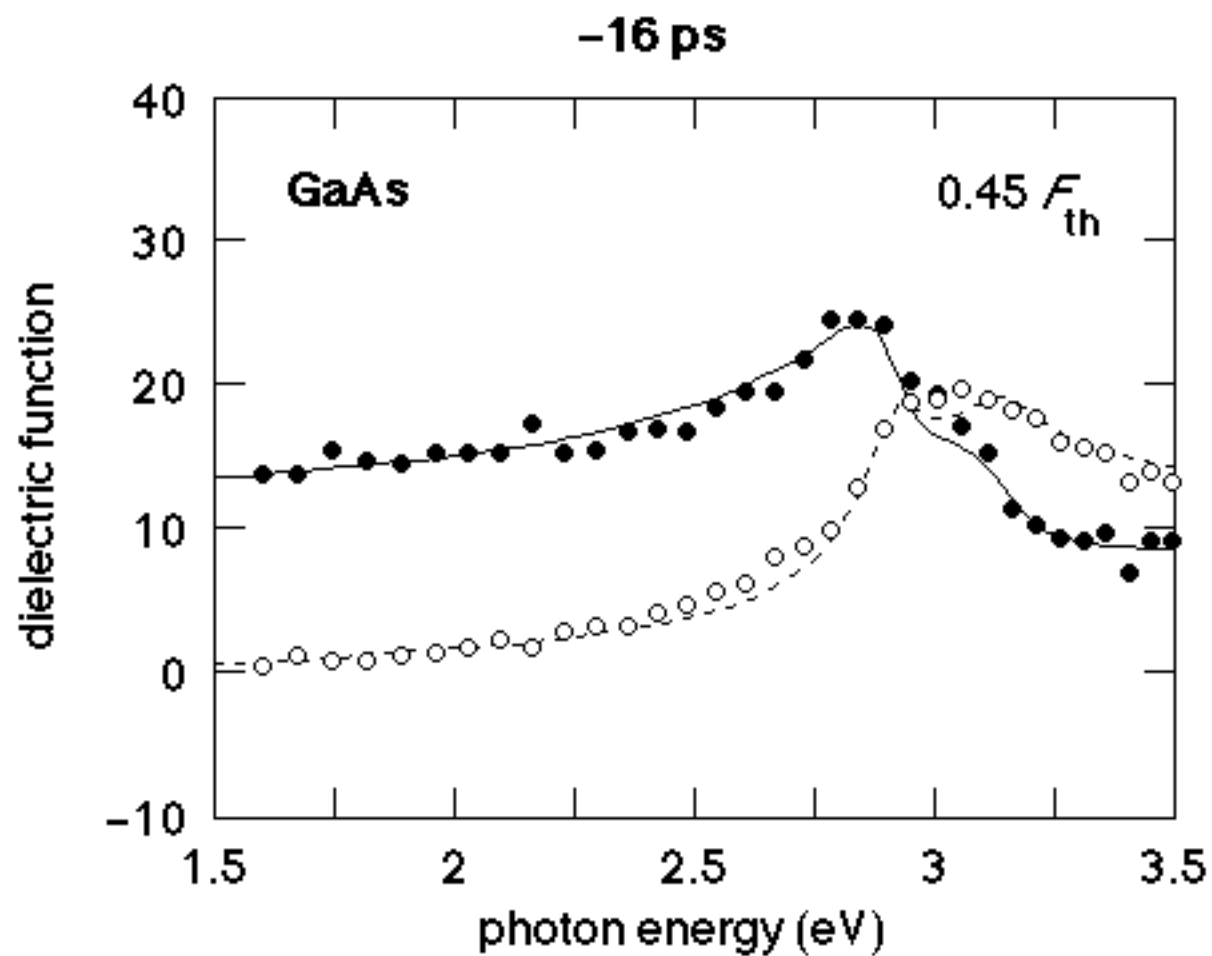

BROADBAND DATA

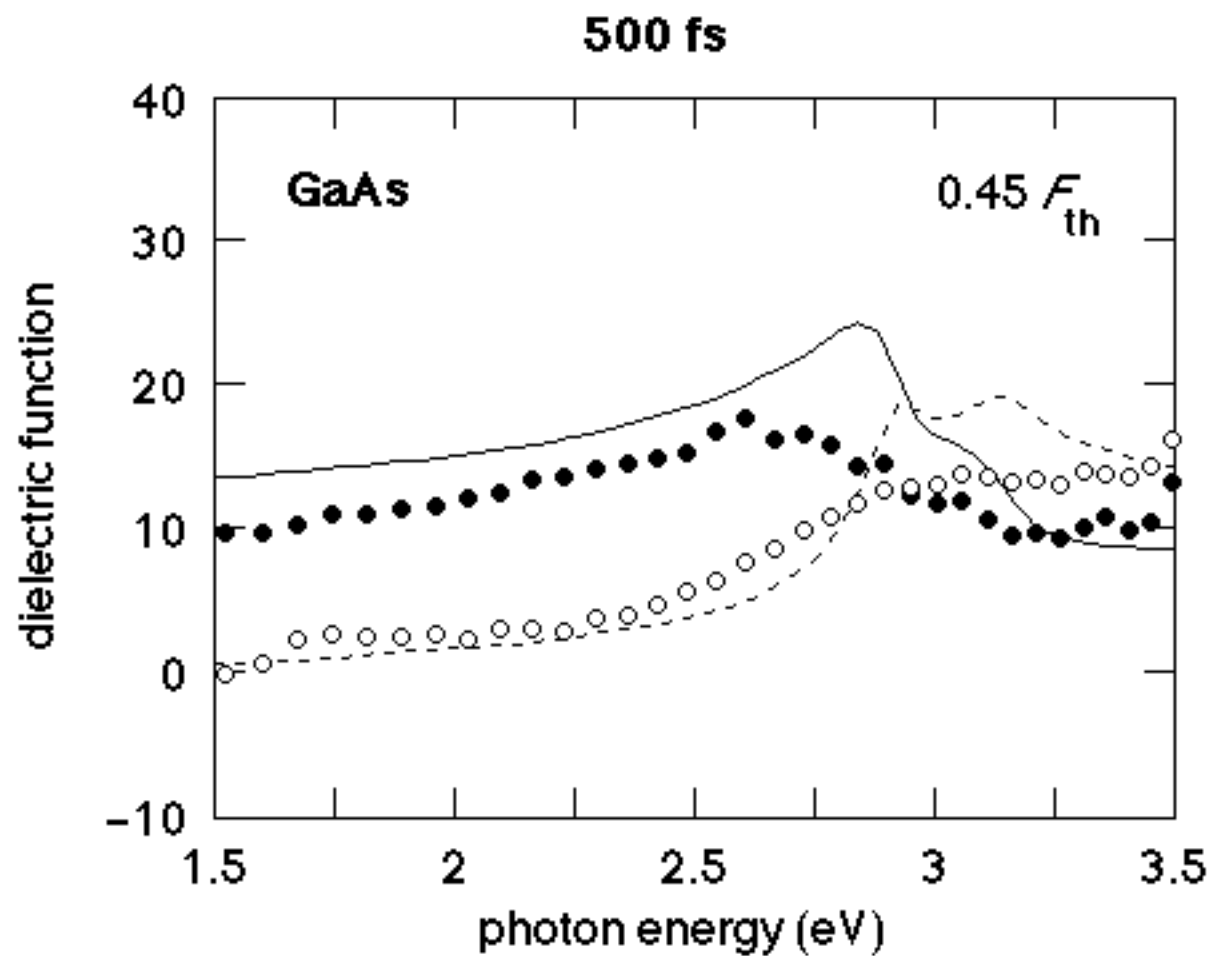

BROADBAND DATA

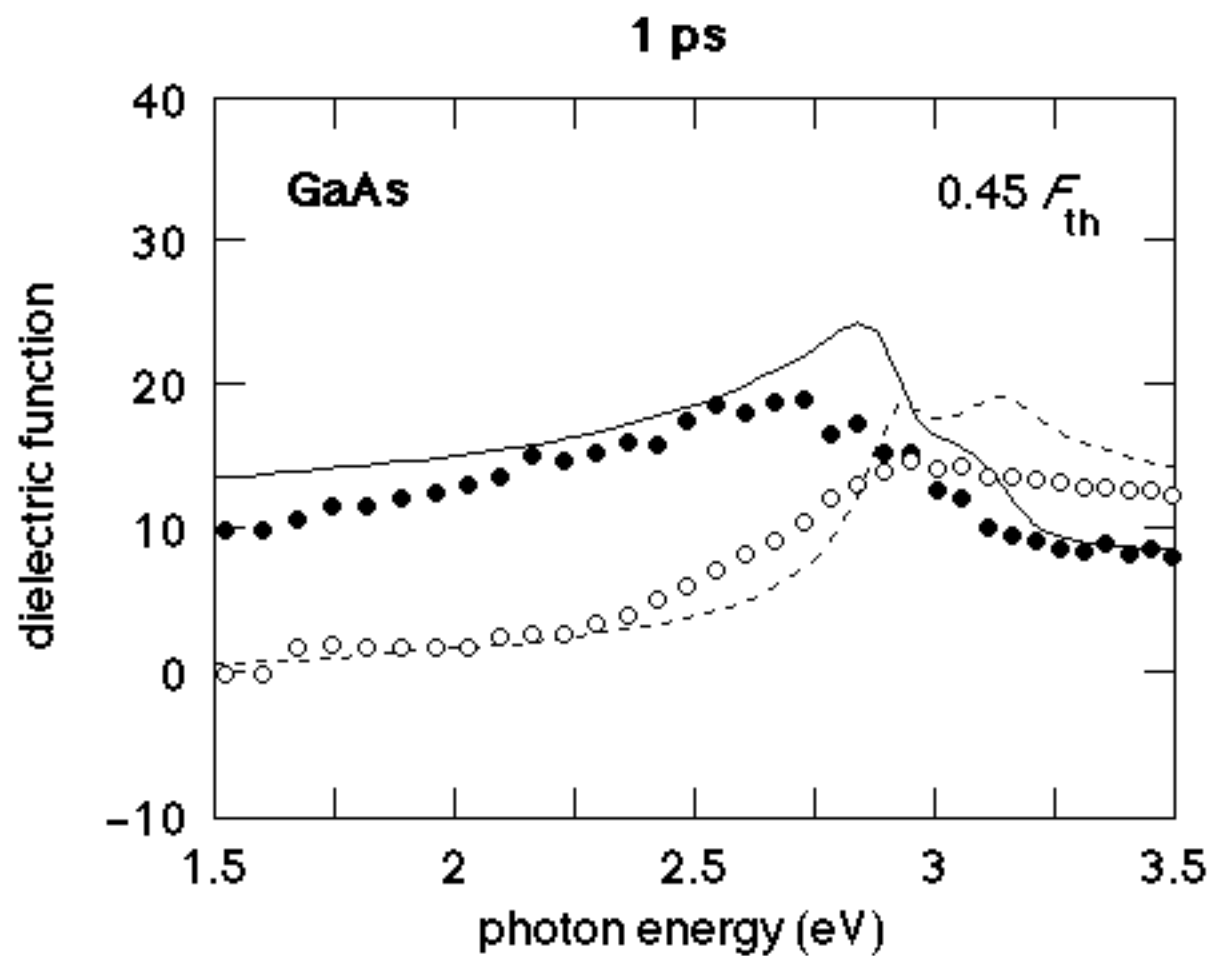

BROADBAND DATA

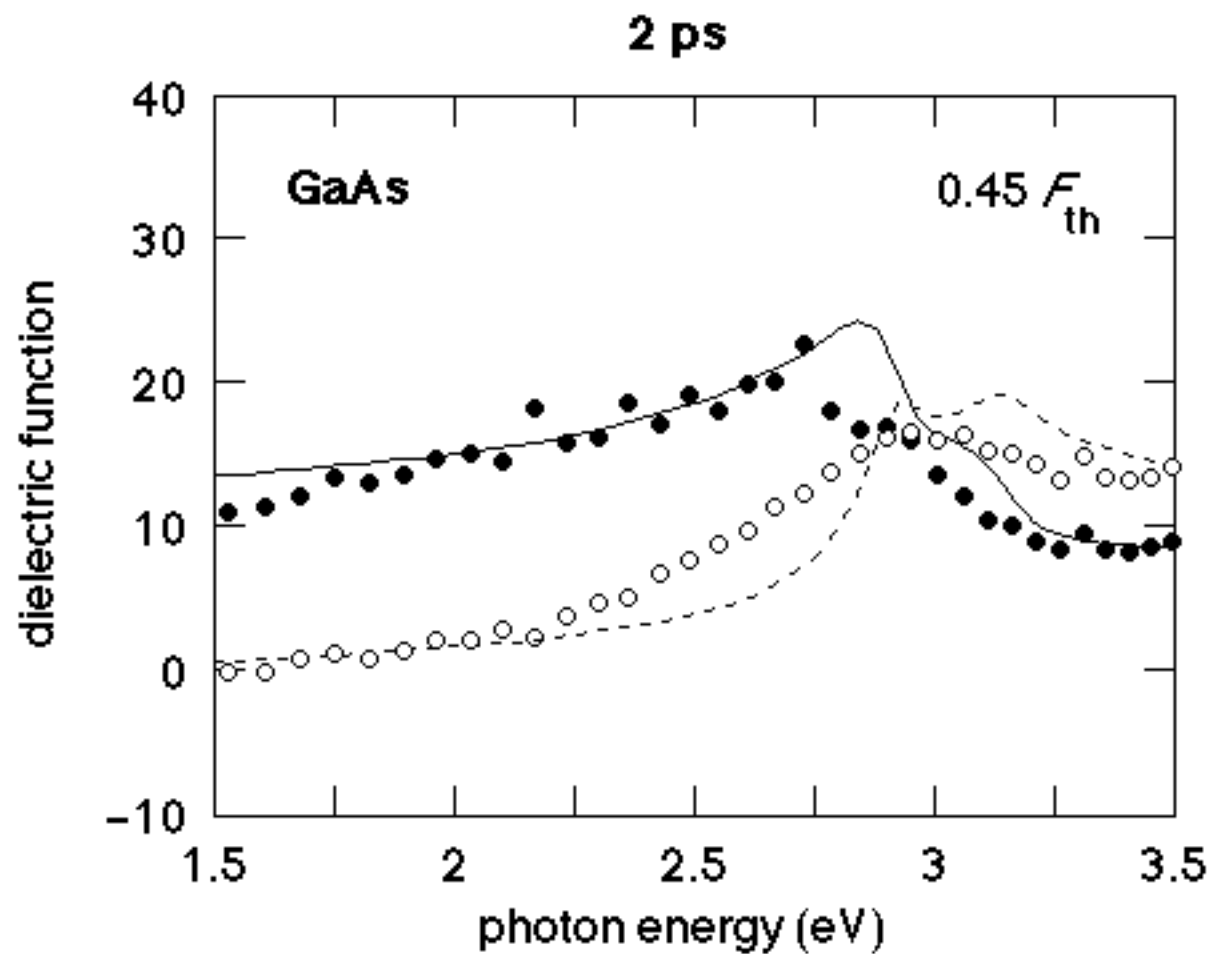

BROADBAND DATA

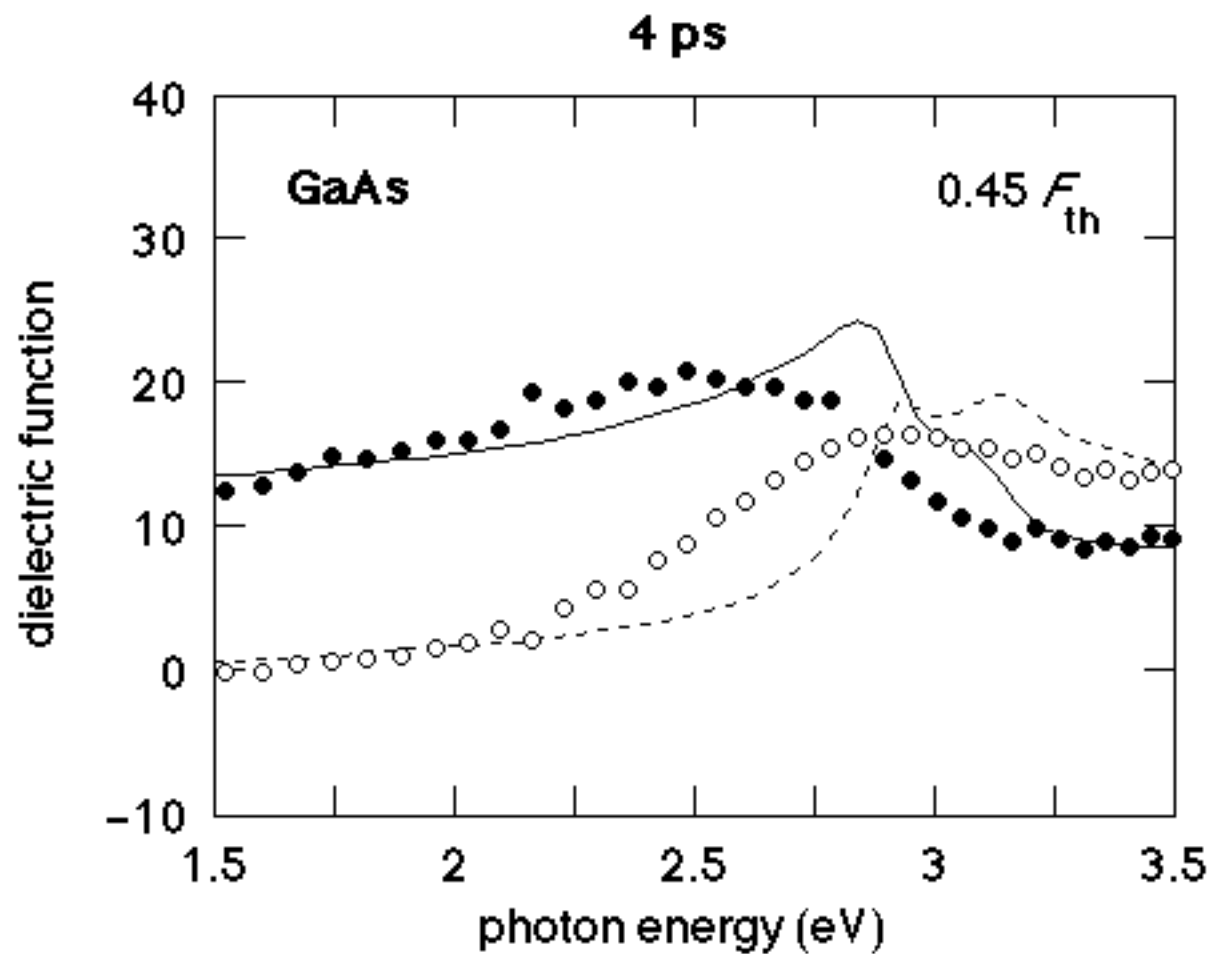

BROADBAND DATA

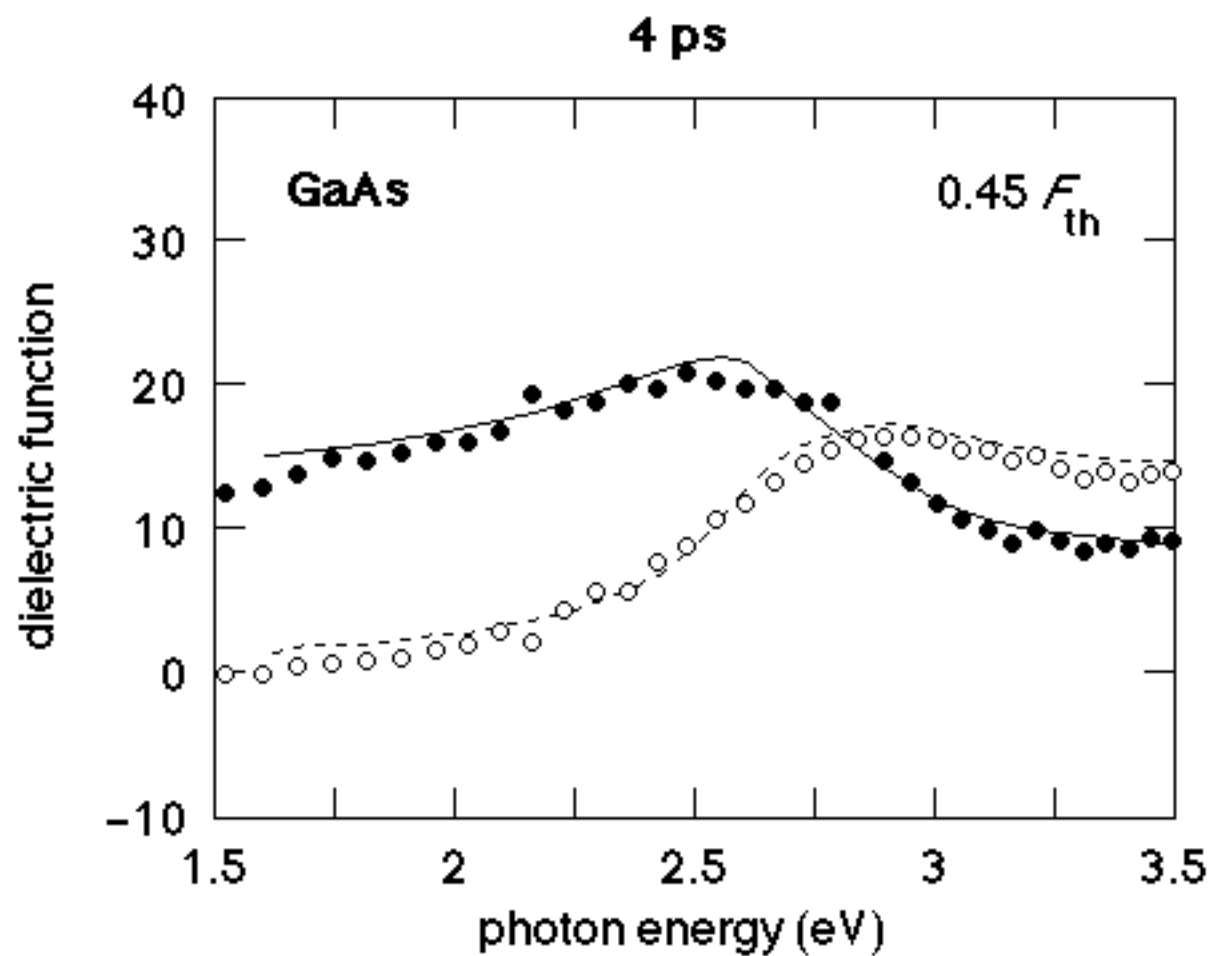

BROADBAND DATA

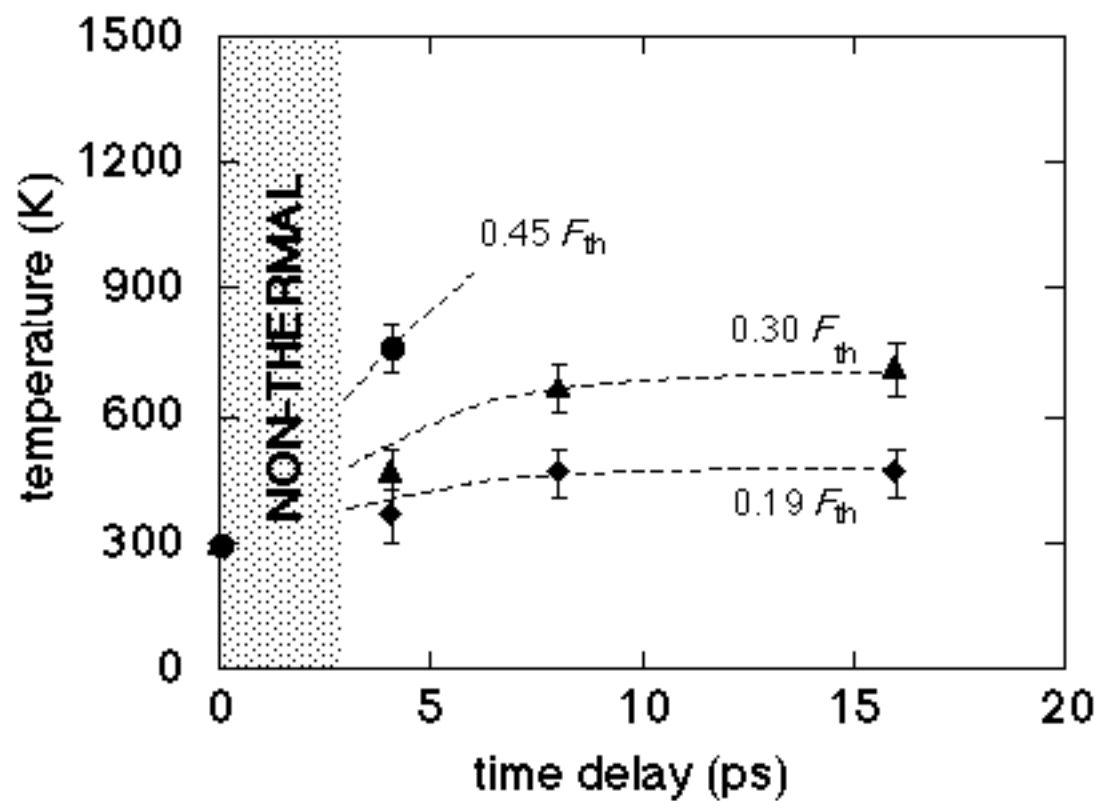

BROADBAND DATA

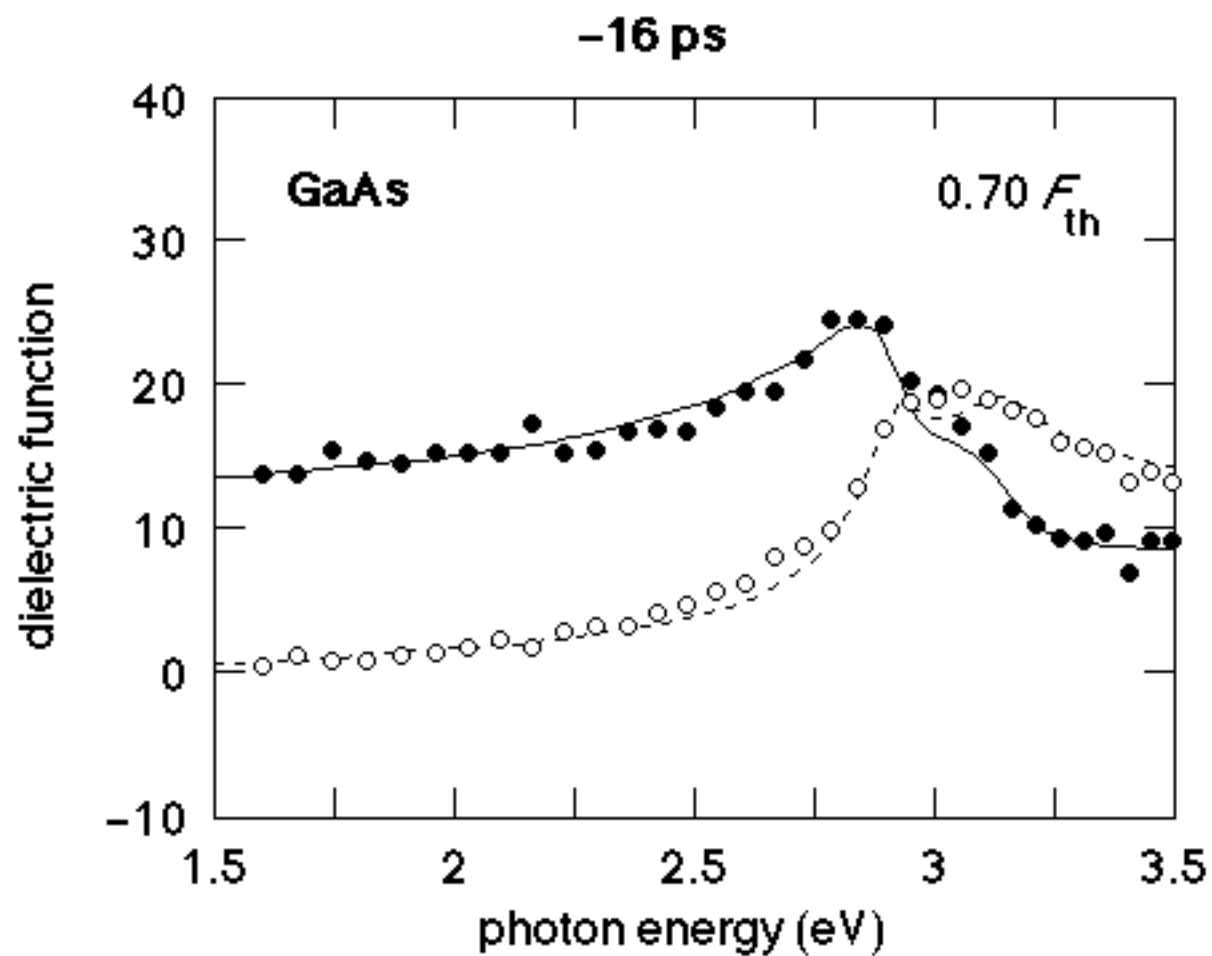

BROADBAND DATA

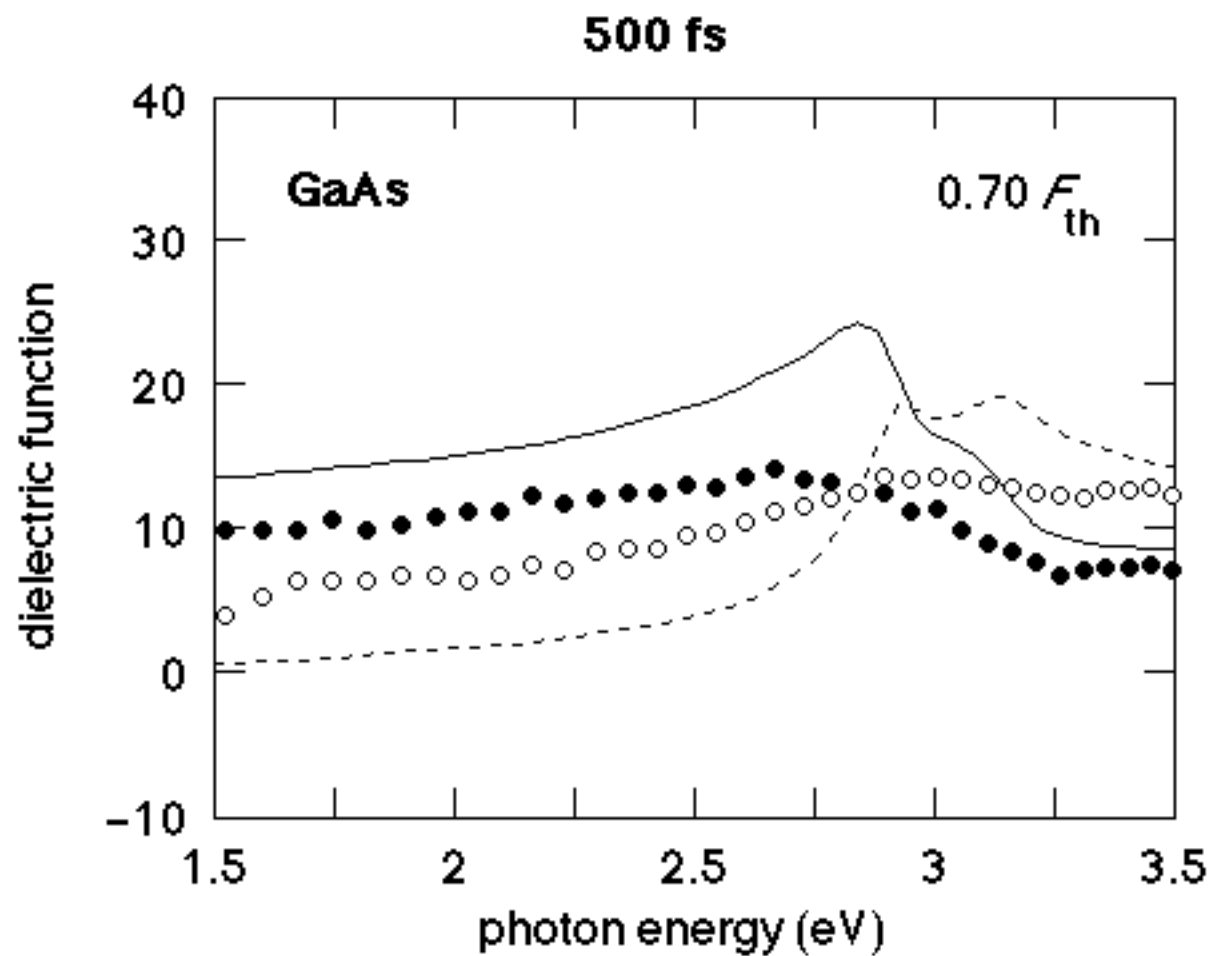

BROADBAND DATA

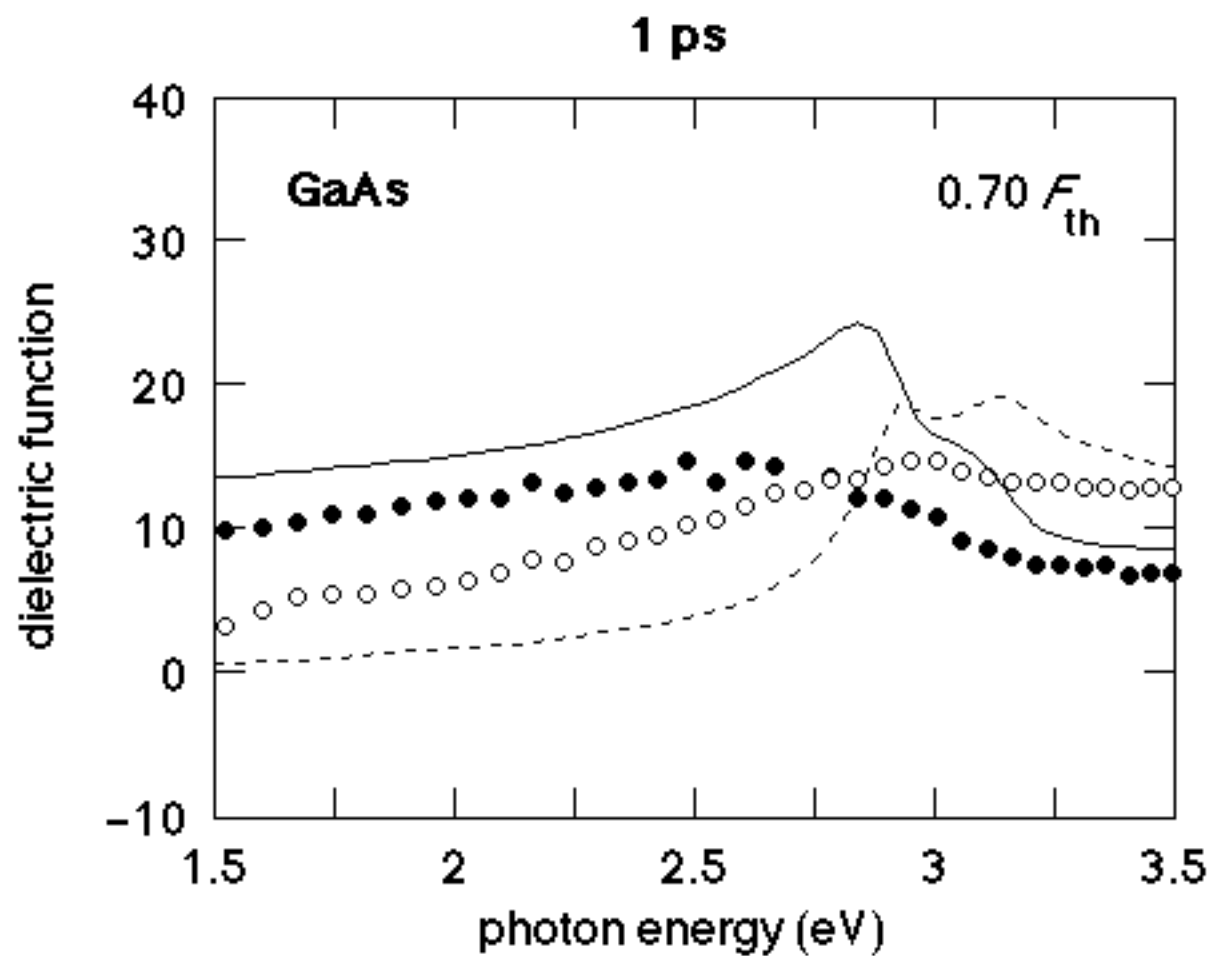

BROADBAND DATA

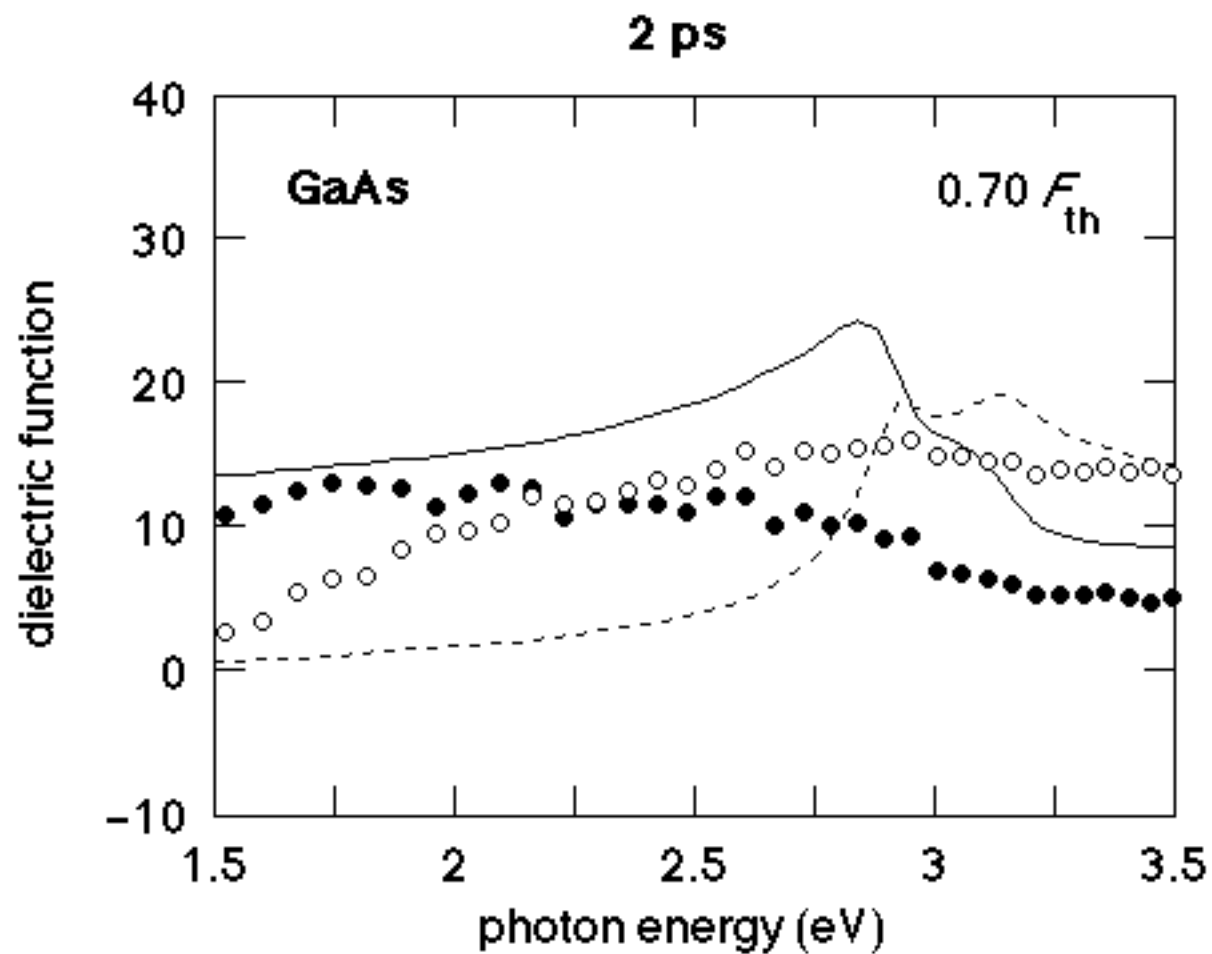

BROADBAND DATA

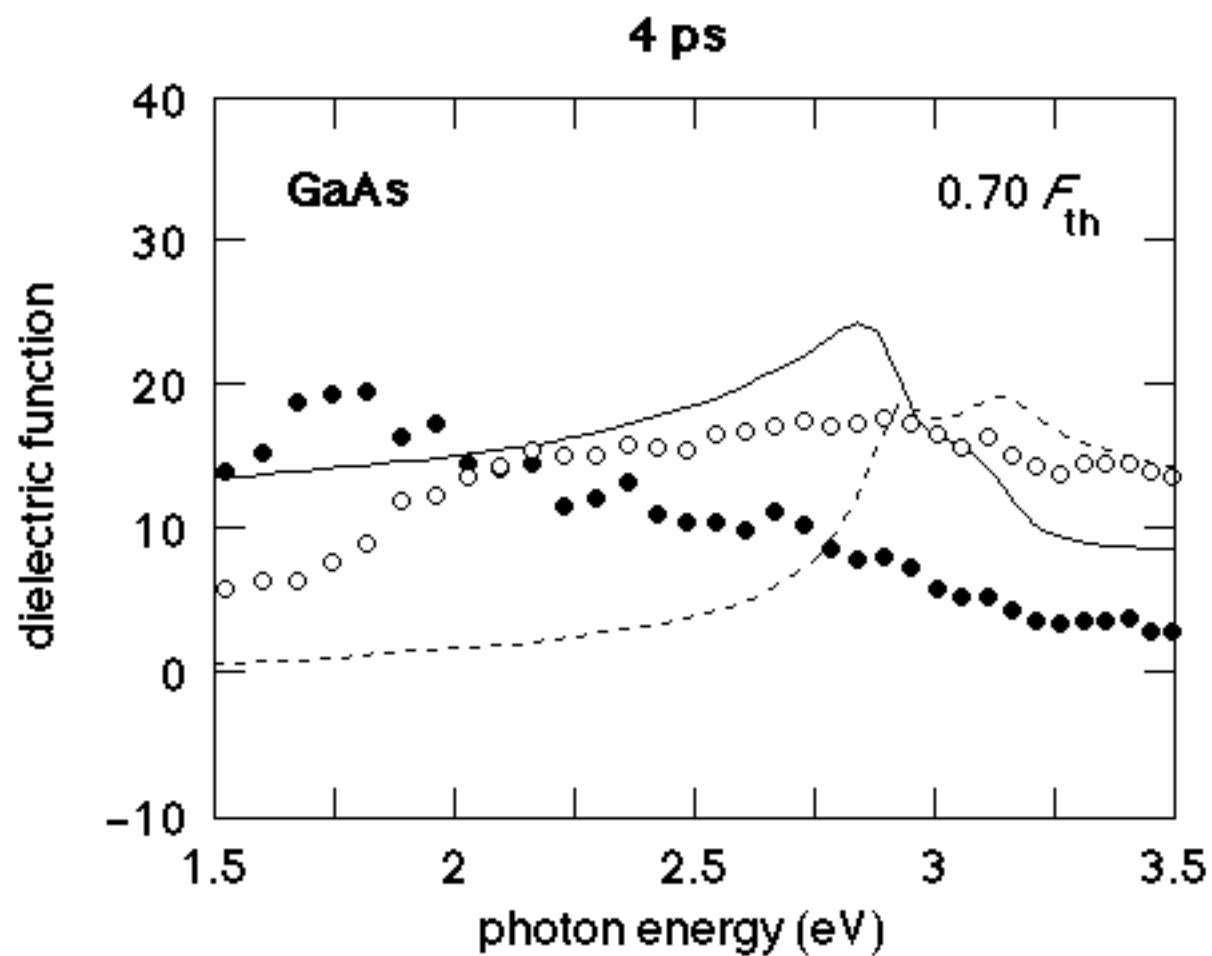

BROADBAND DATA

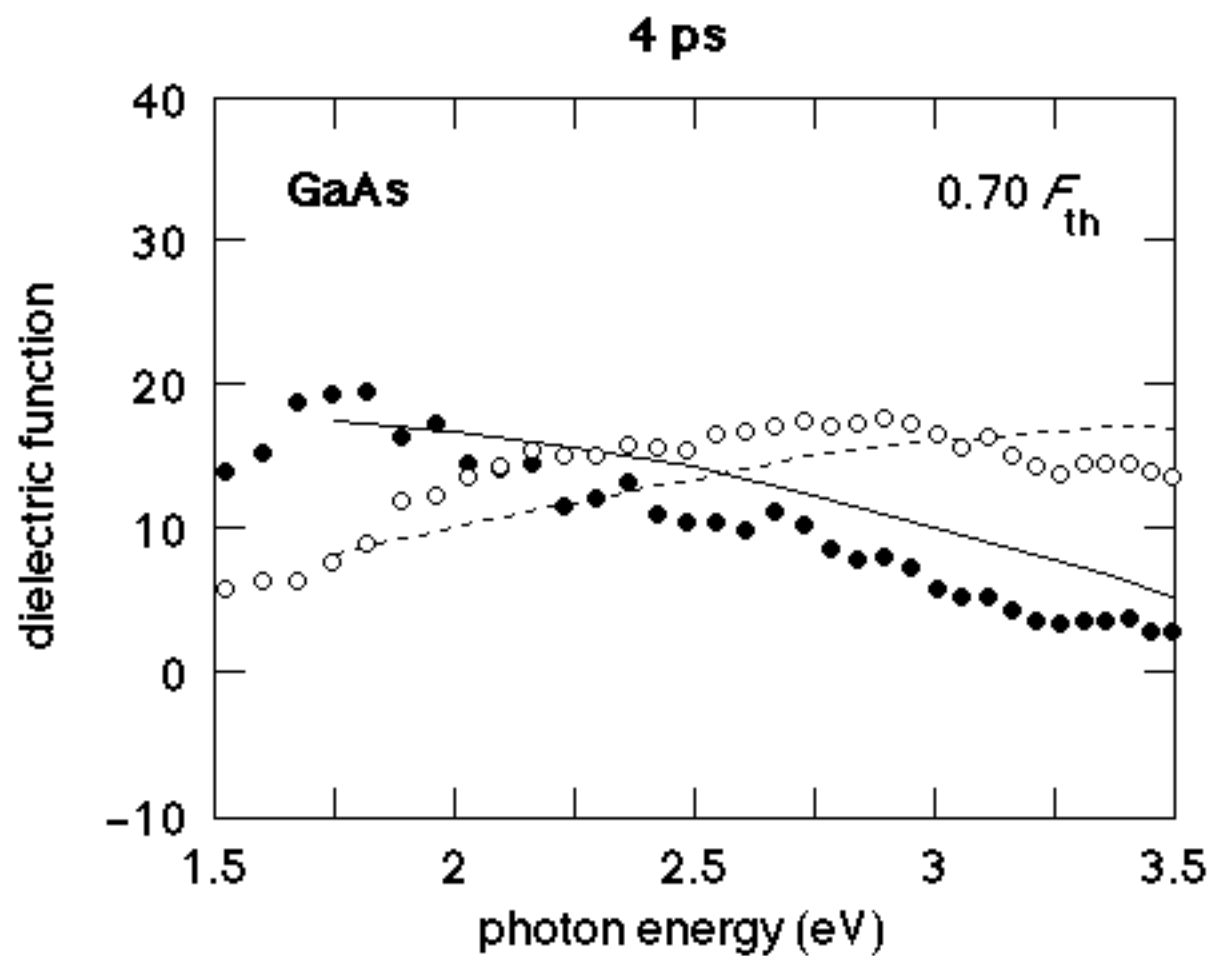

BROADBAND DATA

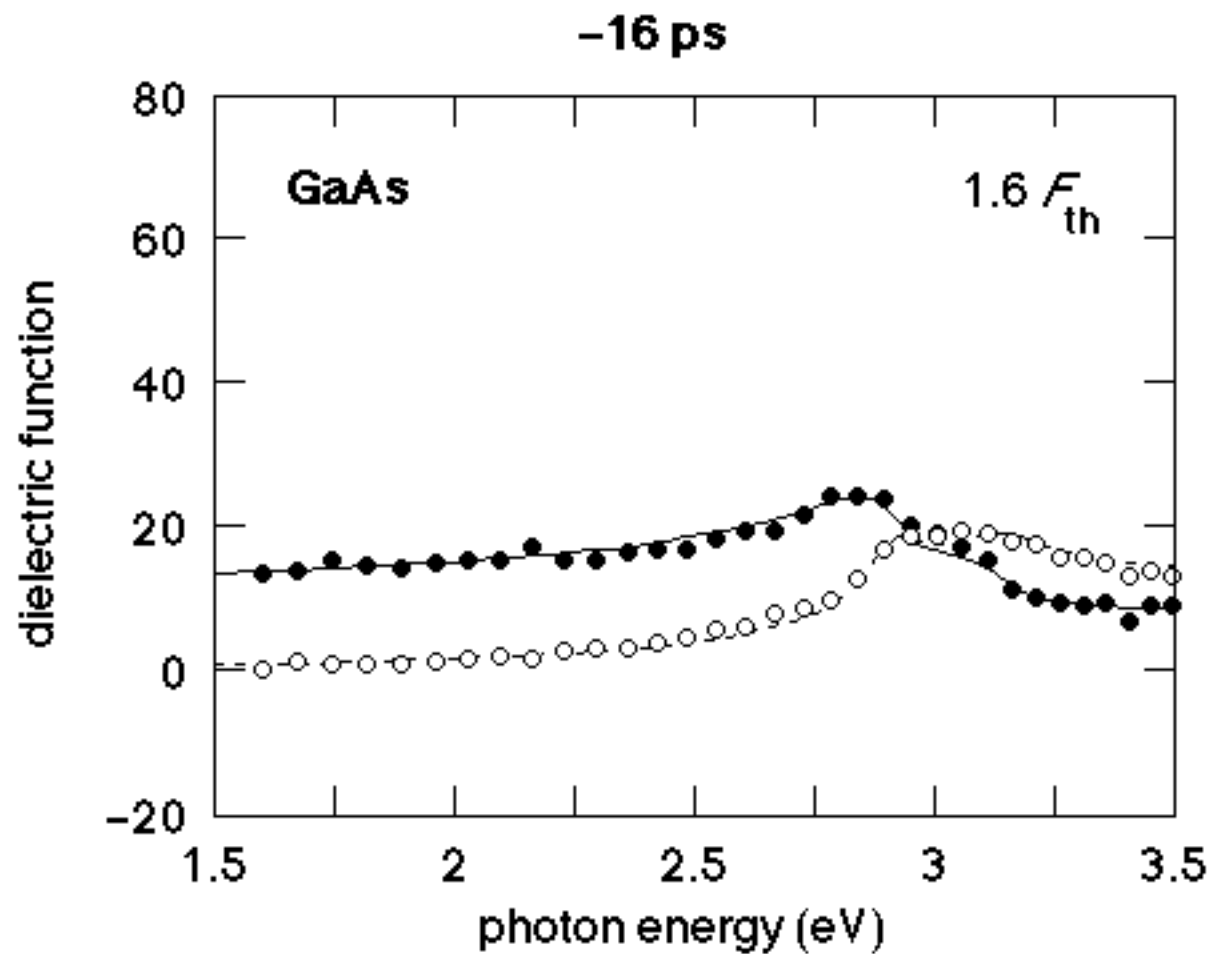

BROADBAND DATA

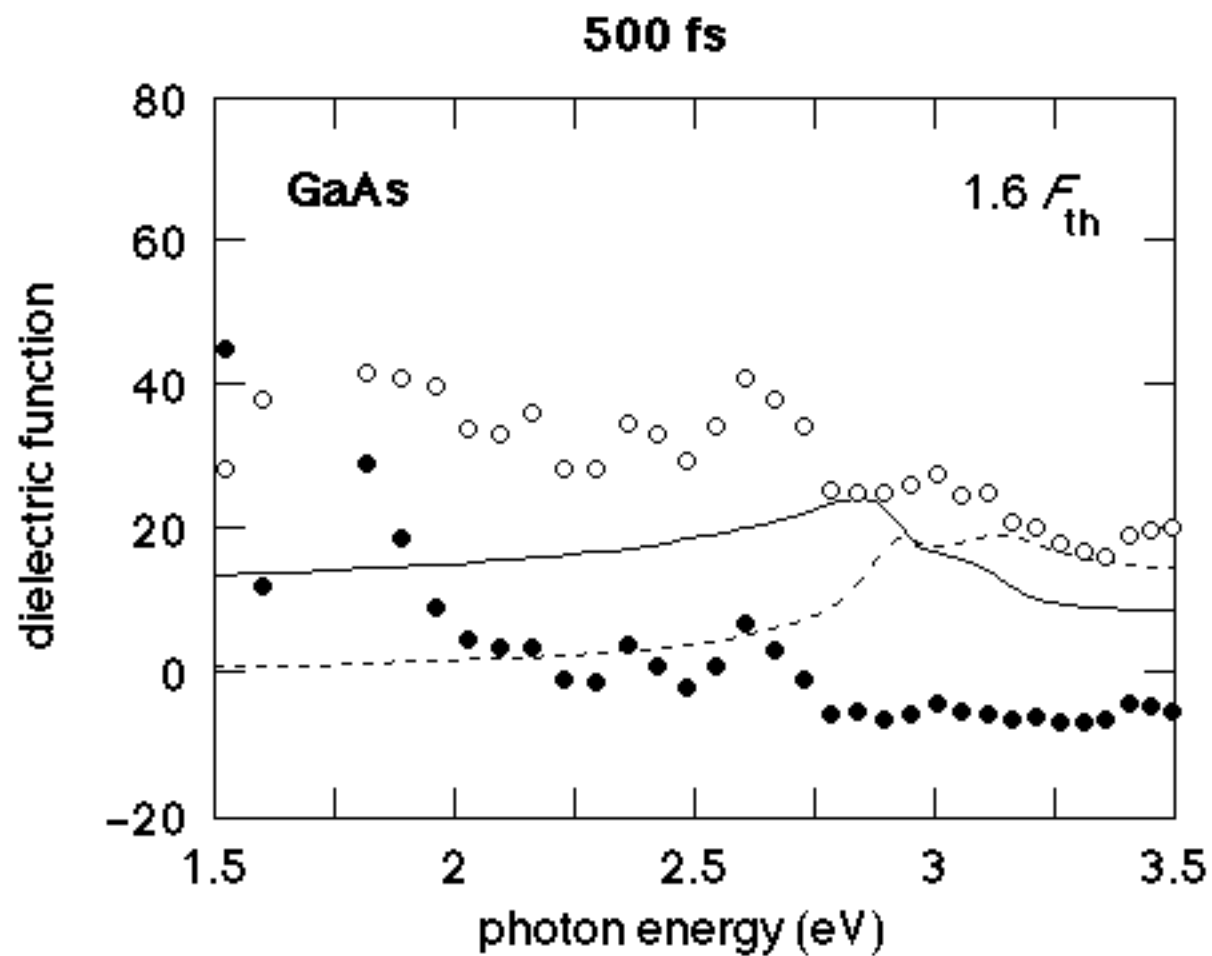

BROADBAND DATA

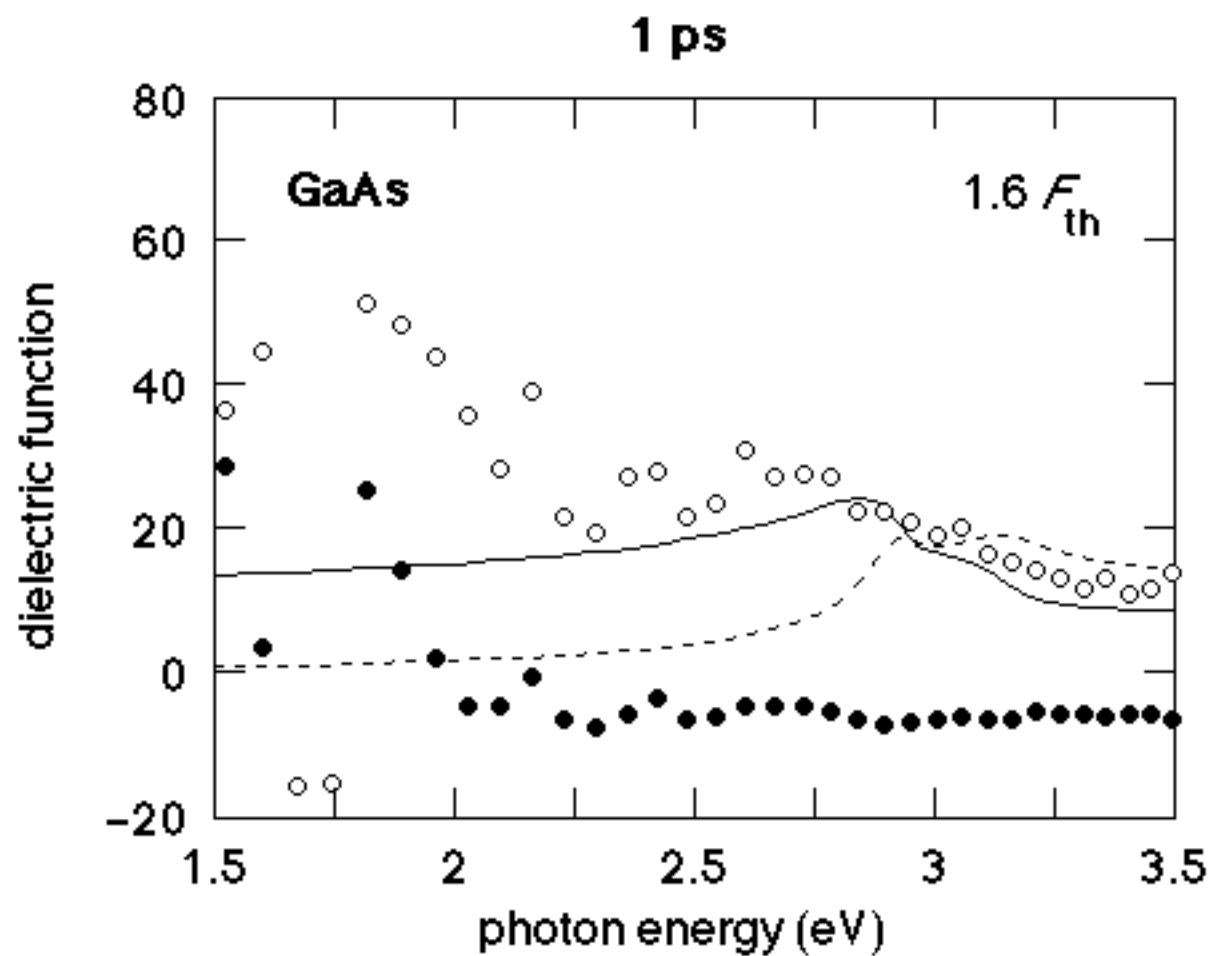

BROADBAND DATA

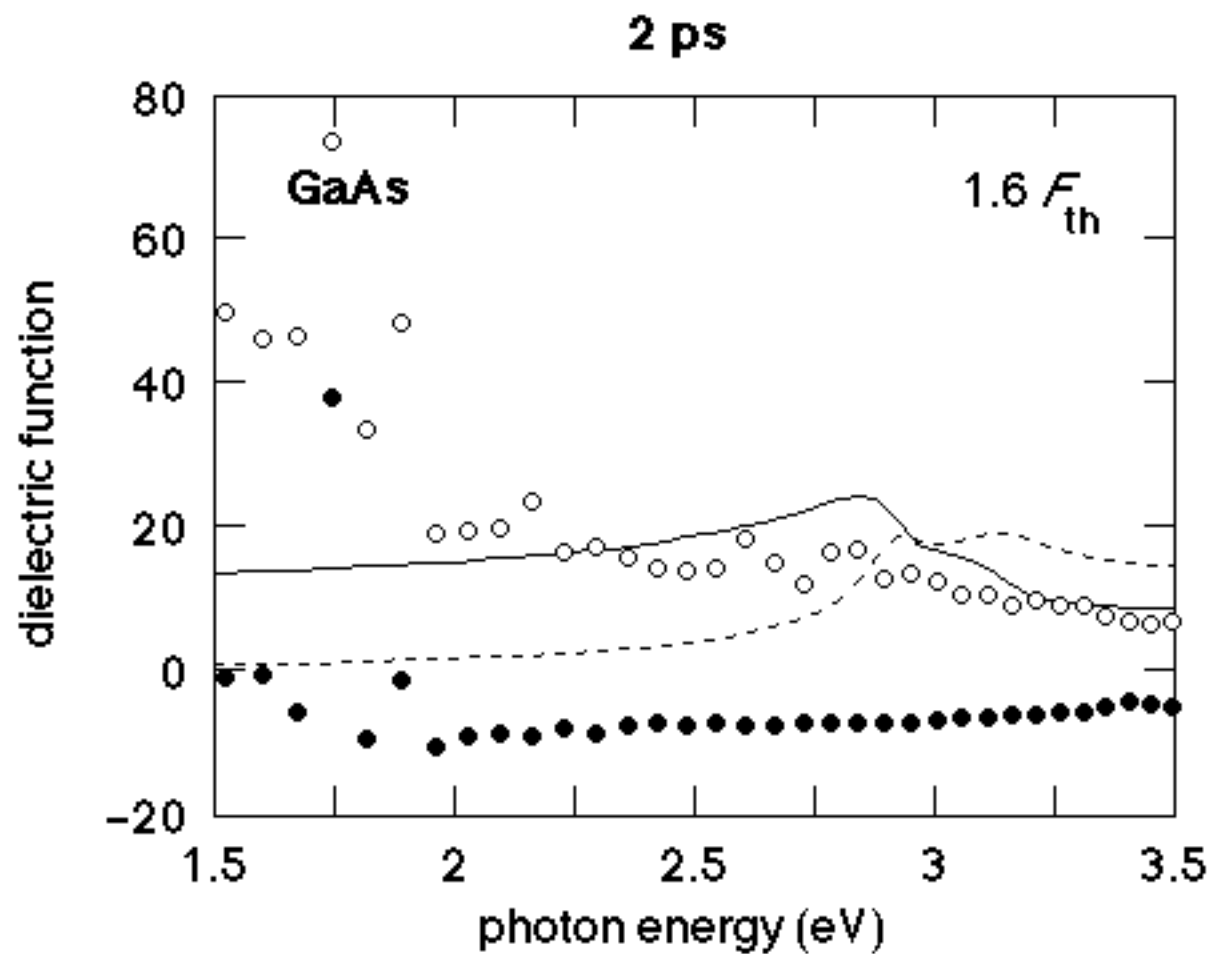

BROADBAND DATA

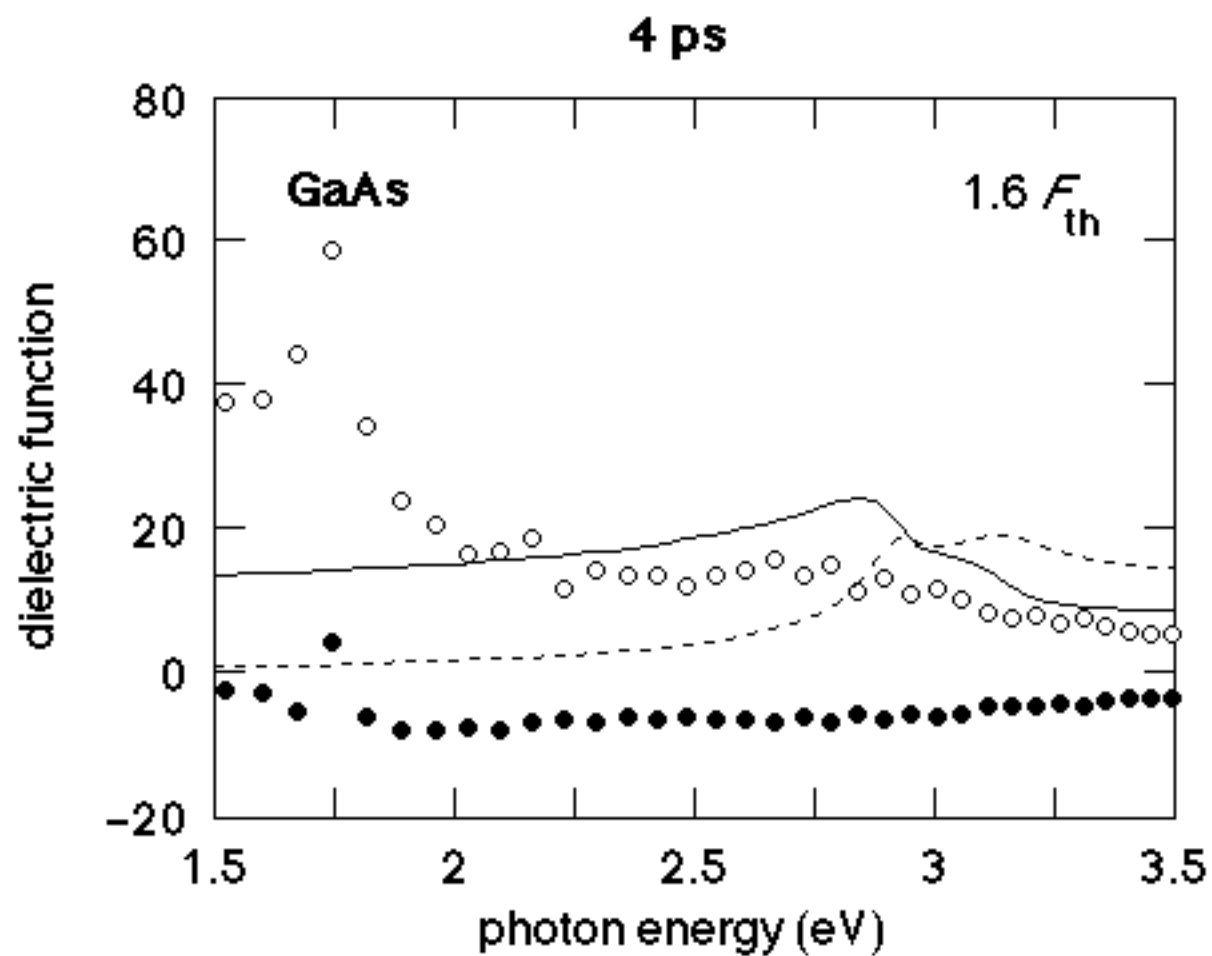

BROADBAND DATA

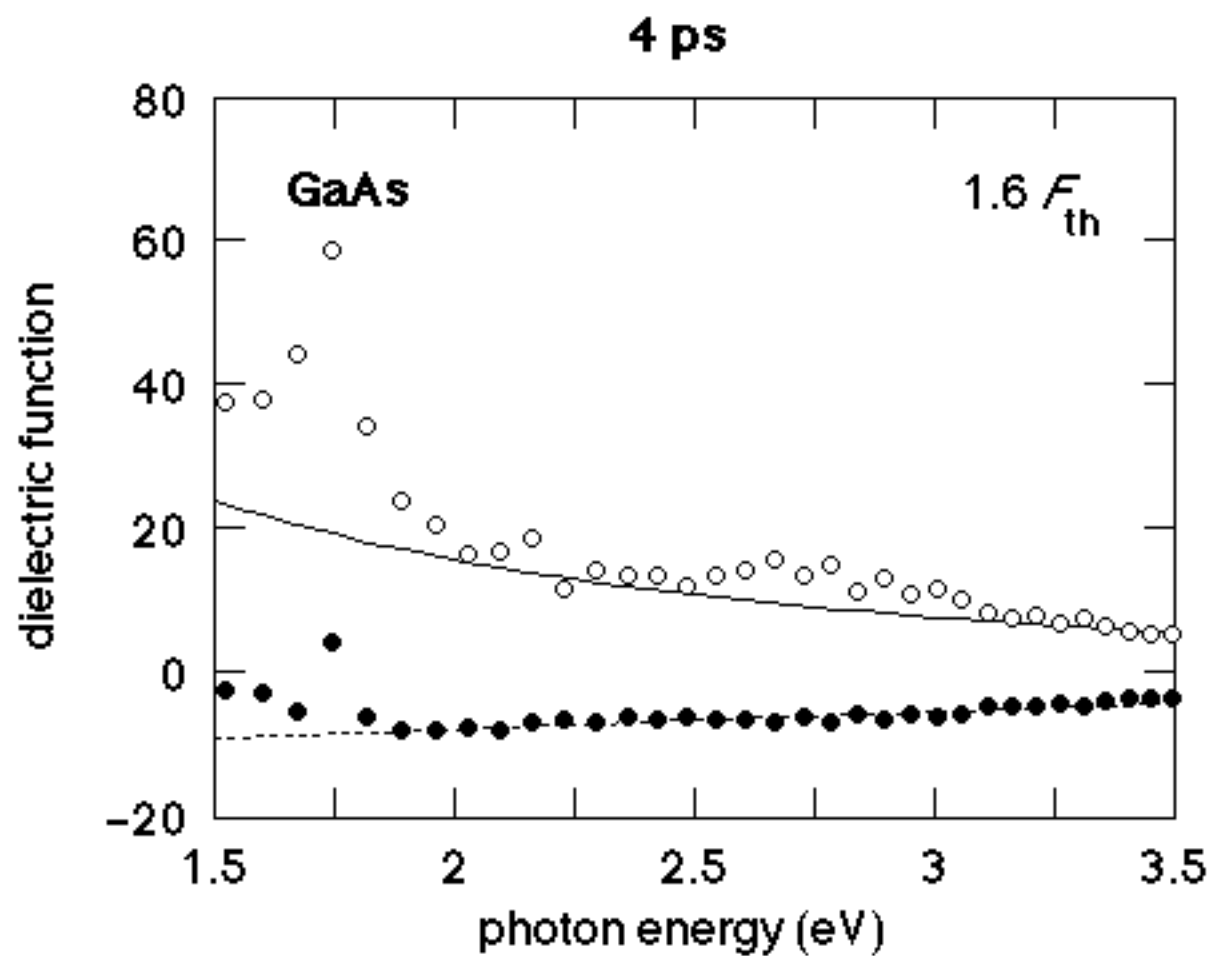

BROADBAND DATA

short
time

long
time

low fluence

medium fluence

high fluence



BROADBAND DATA

short
time

long
time

low fluence

electronic
many-particle
effects

medium fluence

high fluence



BROADBAND DATA

short
time

long
time

low fluence

electronic
many-particle
effects

medium fluence

high fluence

structural
effect?



BROADBAND DATA

short
time

long
time

low fluence

electronic
many-particle
effects

hot lattice

medium fluence

high fluence

structural
effect?



BROADBAND DATA

short
time

long
time

low fluence

hot lattice

electronic
many-particle
effects

medium fluence

lattice disordering

high fluence

structural
effect?



BROADBAND DATA

short
time

long
time

low fluence

electronic
many-particle
effects

hot lattice

medium fluence

lattice disordering

high fluence

structural
effect?

metallic behavior



electronic excitation can drive phonons incoherently, coherently, or impulsively

electronic excitation can drive a structural transition

femtosecond lasers allow us to see the dynamics of the transition



Acknowledgments

Prof. Bloembergen
Prof. Ehrenreich
Prof. Kaxiras
Prof. Aziz

ONR N00014-89-J1023
NSF DMR 89-20490

<http://mazor-www.harvard.edu>

