



MEMORIZATION OR UNDERSTANDING: ARE WE TEACHING THE RIGHT THING?

Eric Mazur

*Physics and Applied Physics
Harvard University*

AAAS

AMSIE '97, Seattle

15 February 1997

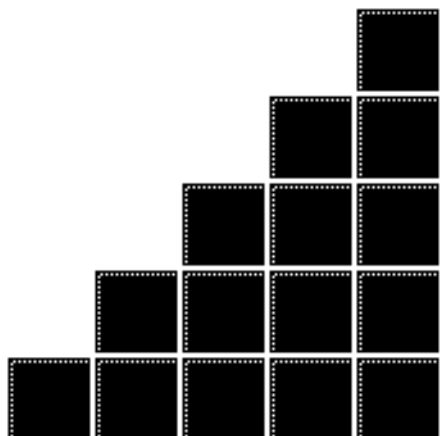

- ① Why reform?
- ② How reform?
- ③ Challenges



THE CAUSE

Are we teaching the right thing...?

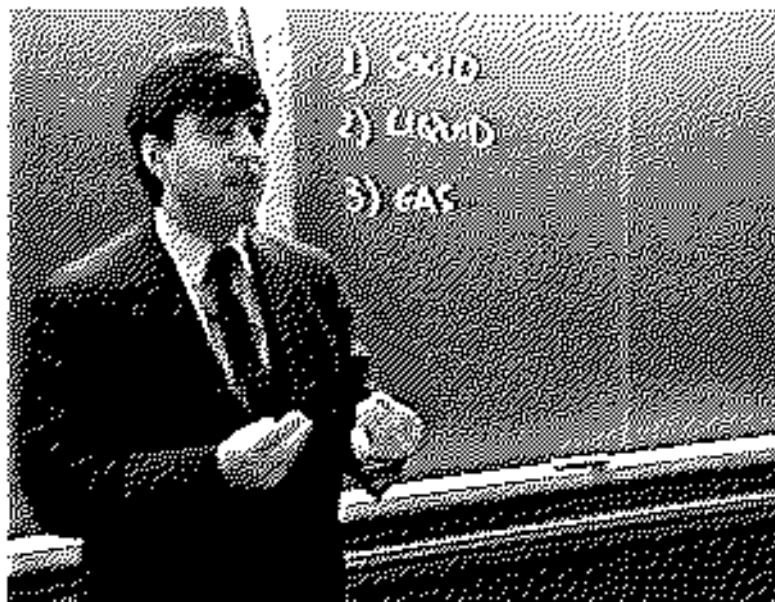

THE CAUSE

Traditional question:

Calculate:

- (a) the current in the $2\text{-}\Omega$ resistor, and
- (b) the potential difference between points a and b .

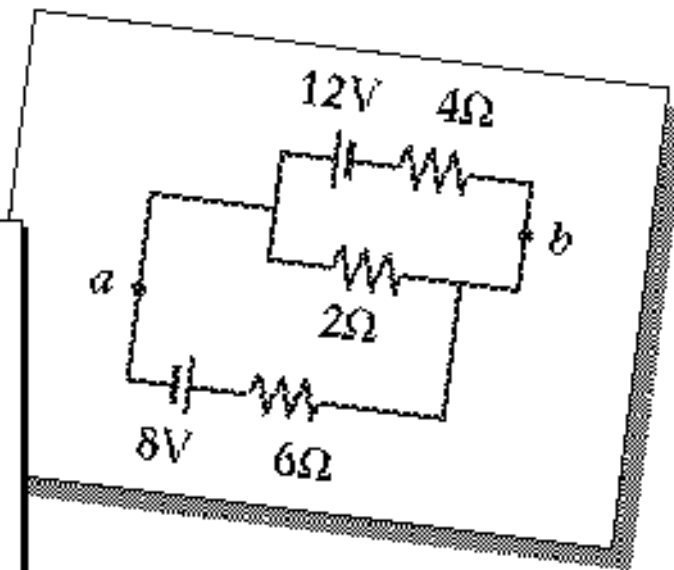

THE CAUSE

Conceptual question:

When S is closed, what happens to the:

- (a) intensities of A and B ?
- (b) intensity of C ?
- (c) current through battery?
- (d) voltage drop across A , B , and C ?
- (e) total power dissipated?

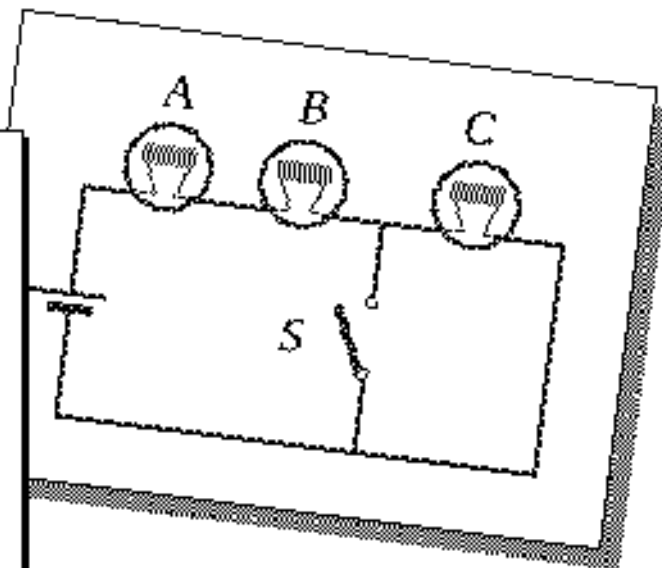

THE CAUSE

Results

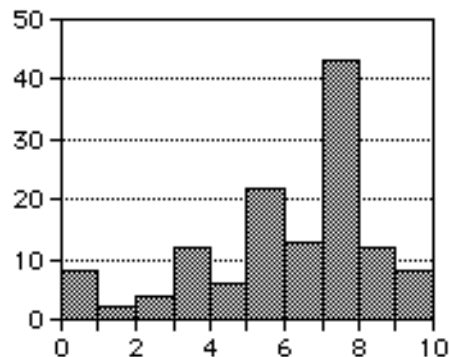

Traditional

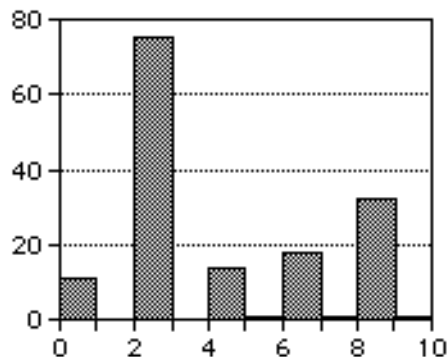

Conceptual



THE CAUSE

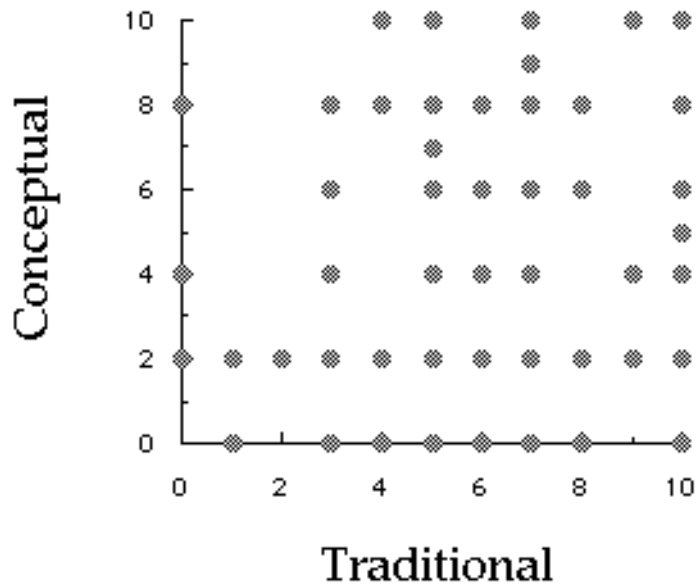

THE CAUSE

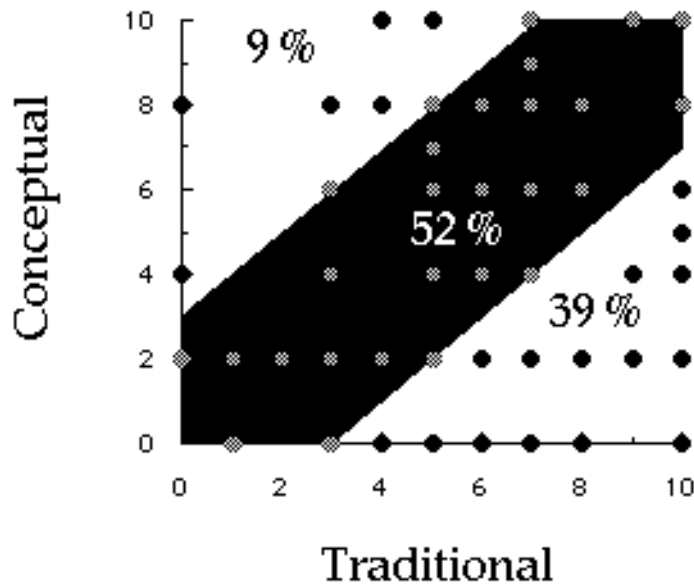

- ① Why reform?
- ② How reform?
- ③ Challenges



PEER INSTRUCTION



Why peer instruction?

PEER INSTRUCTION

Peer Instruction:

- prerequisites
- lectures
- *ConcepTest*TM
- feedback



Is it any good...?

- ① Results
- ② Student reactions



Results

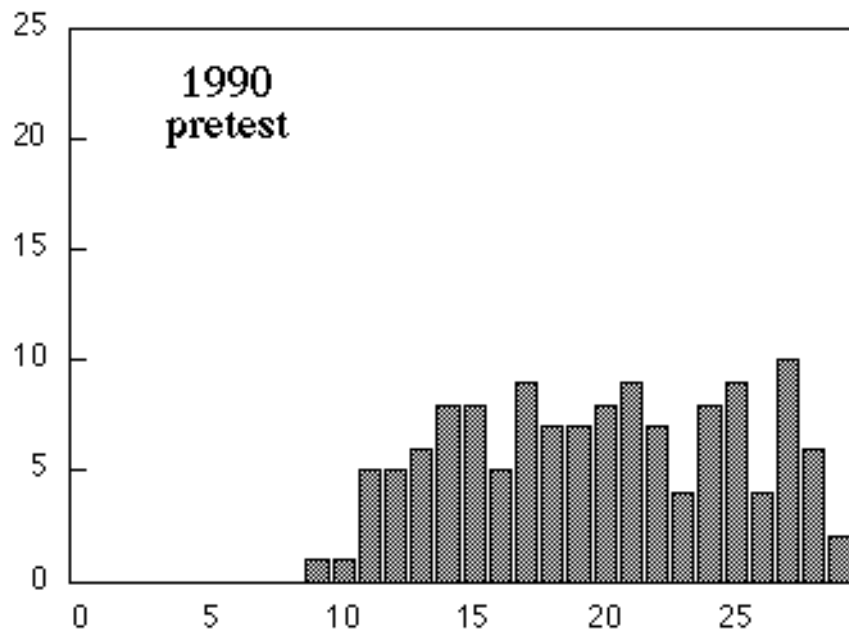

Results

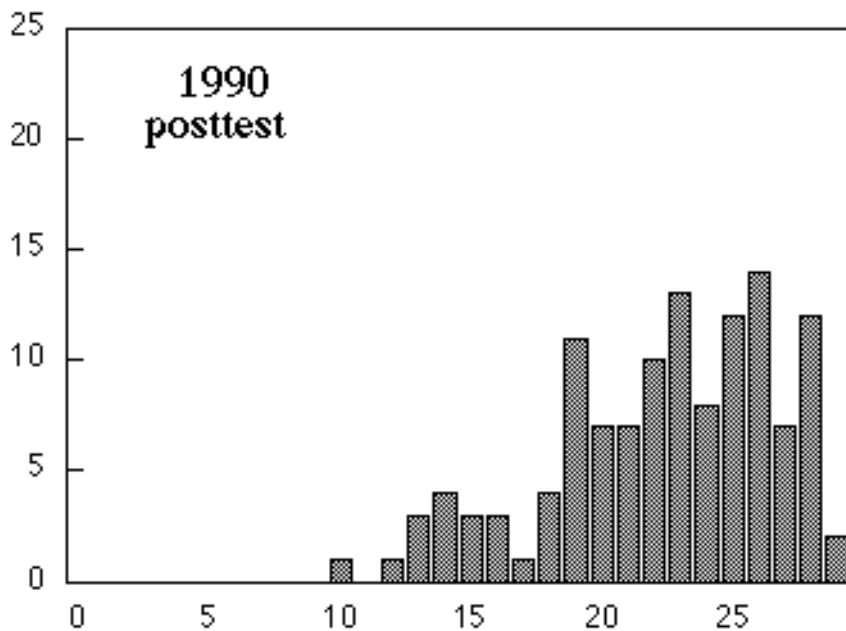

Results

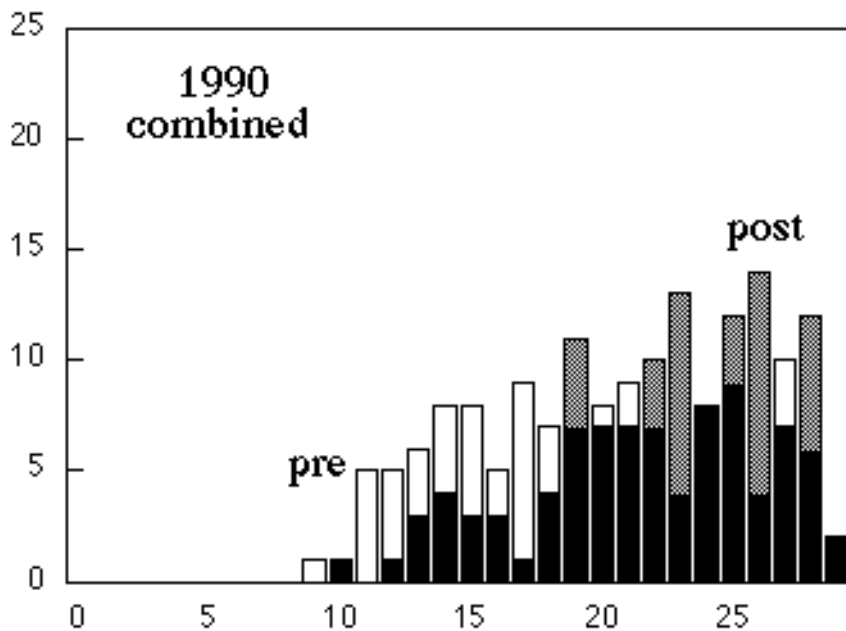

Results

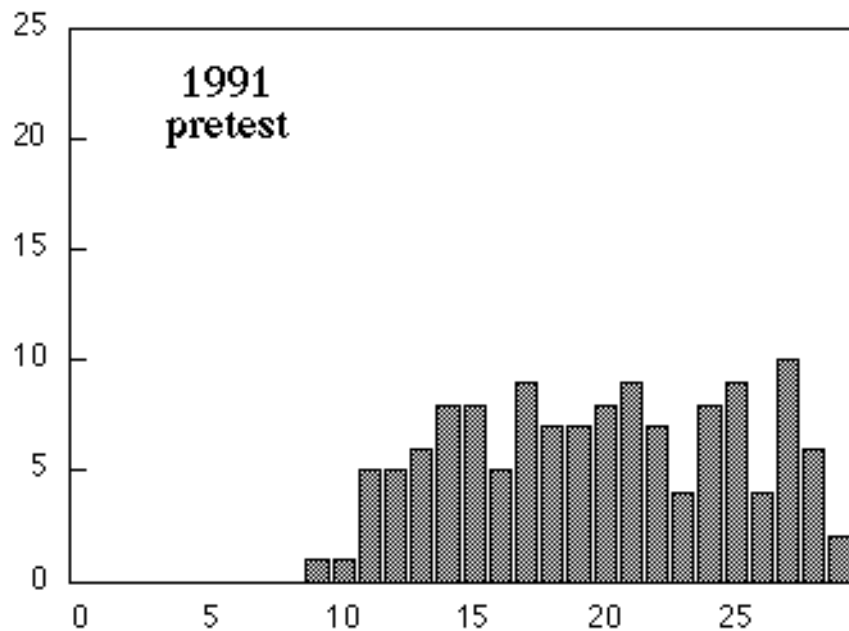

Results

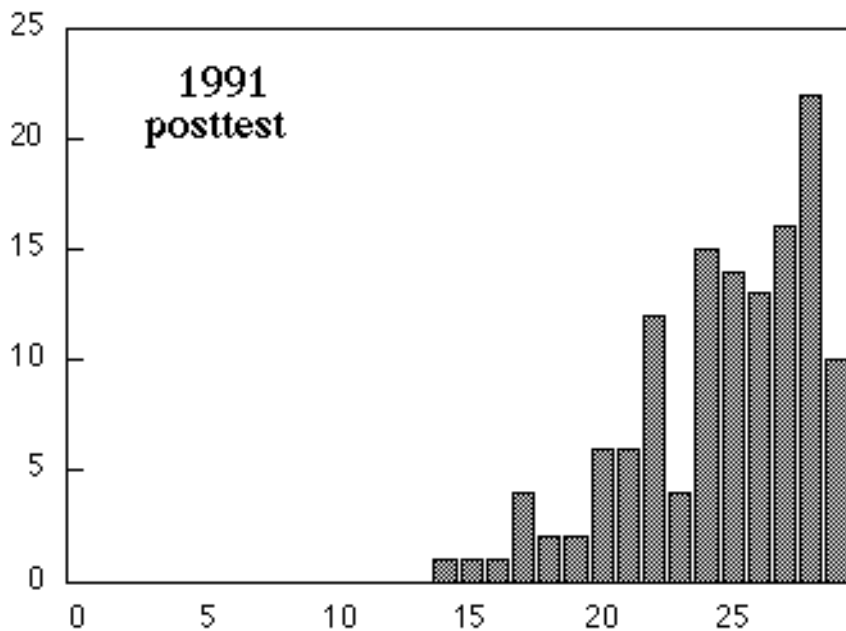

Results

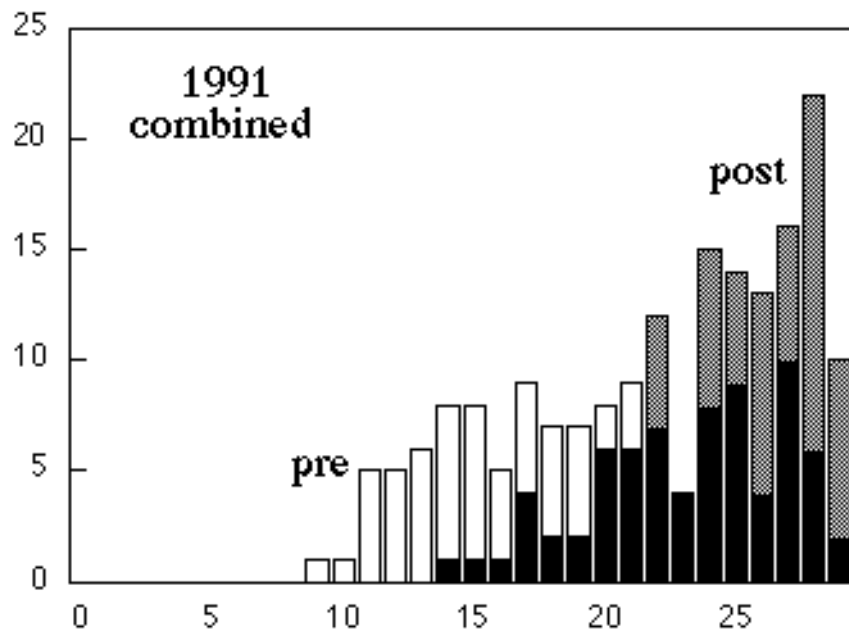

Results

What about problem solving...?



Results

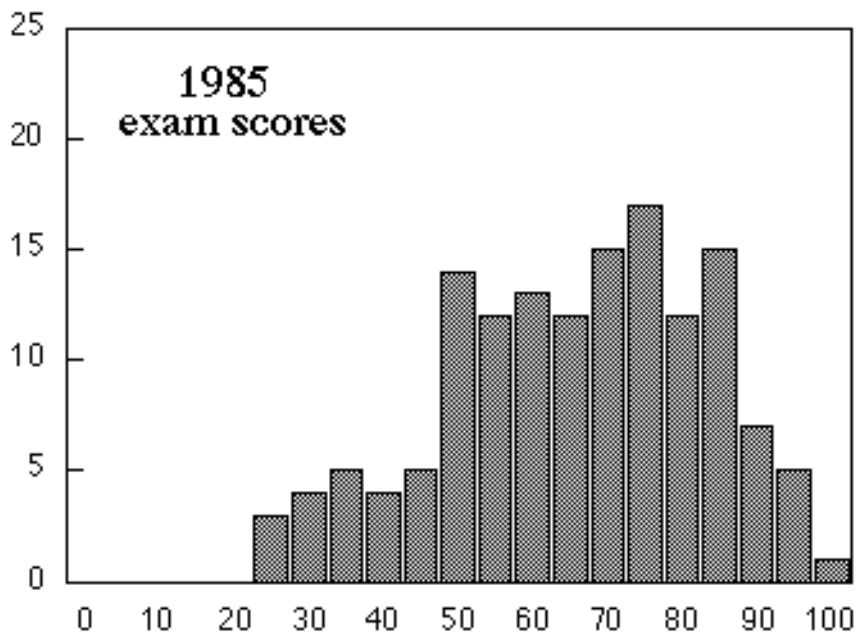

Results

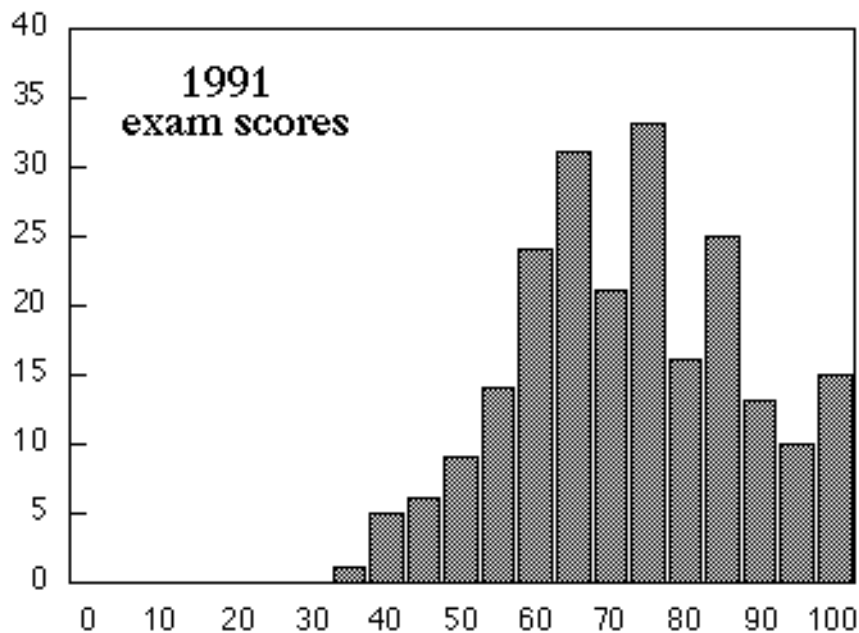

Results

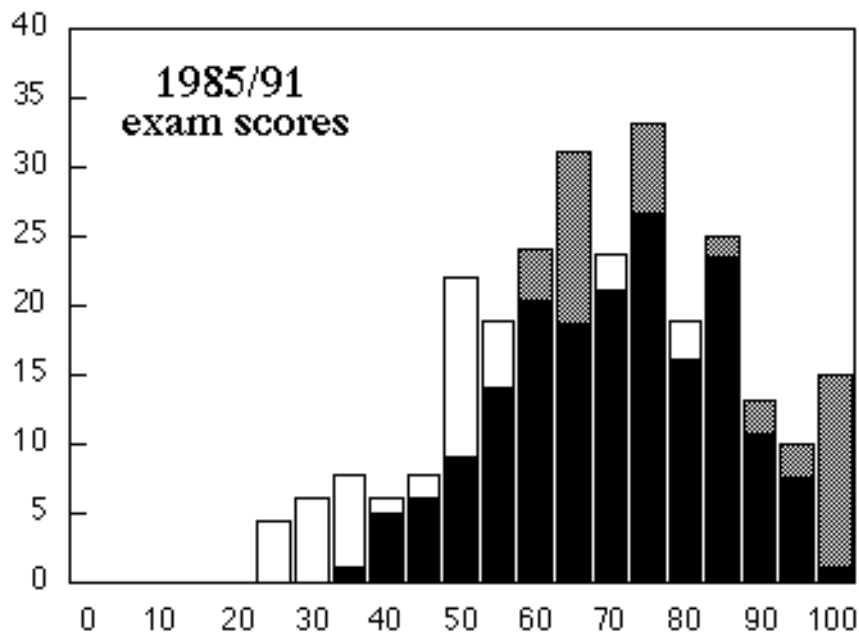

- ➊ Why reform?
- ➋ How reform?
- ➌ Challenges



CHALLENGES

- scepticism
- initial effects
- mismatch

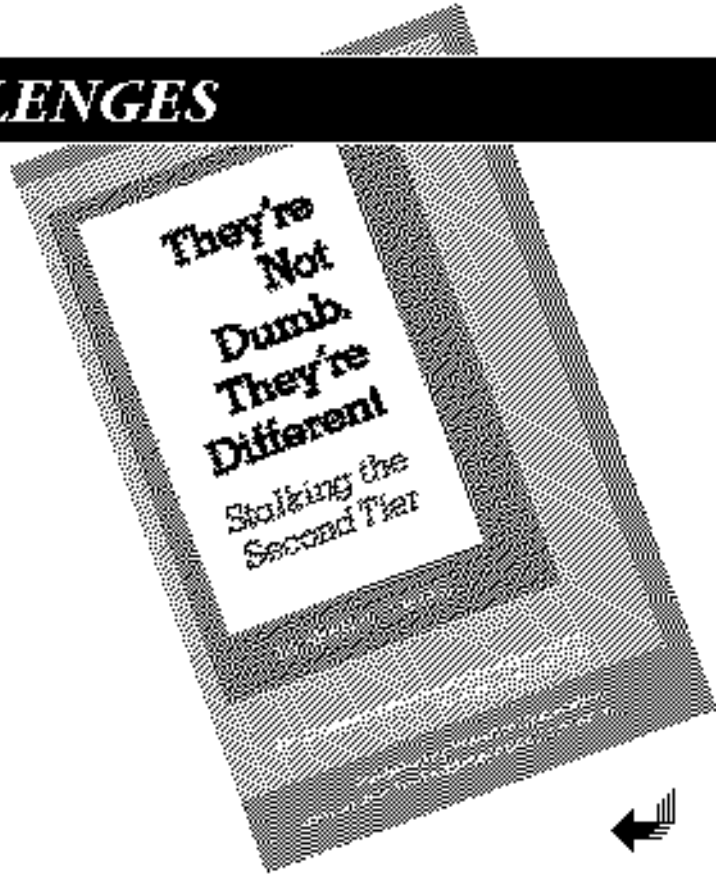

Acknowledgments

Deborah Alpert (Harvard)
David Borthwick (Harvard)
Bob Flaherty (Apple)
David Hestenes (ASU)
Andrew McKinney (Harvard)

© 1997 Eric Mazur

Web Site: <http://mazur-www.harvard.edu>



Thank you!