

Flat space, deep learning



Program on Teaching and Learning Innovation
UNISAL
Lorena, Brazil, 19 March 2014



Flat space, deep learning



A large white oval with a black border containing the Twitter logo and the handle "@eric_mazur".

Program on Teaching and Learning Innovation
UNISAL
Lorena, Brazil, 19 March 2014

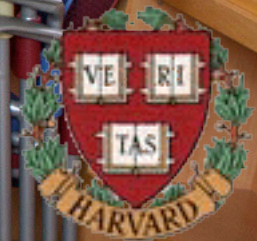

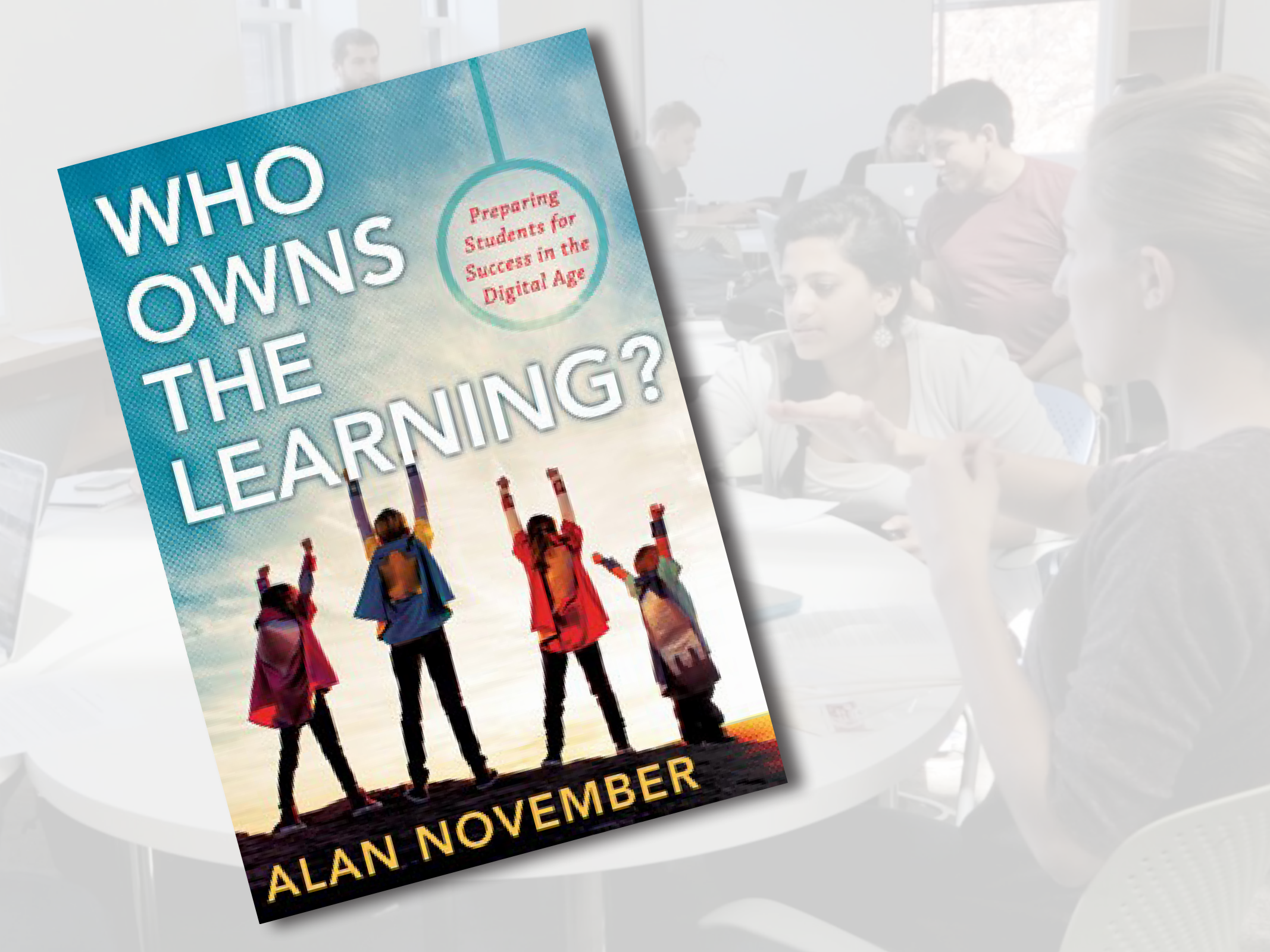
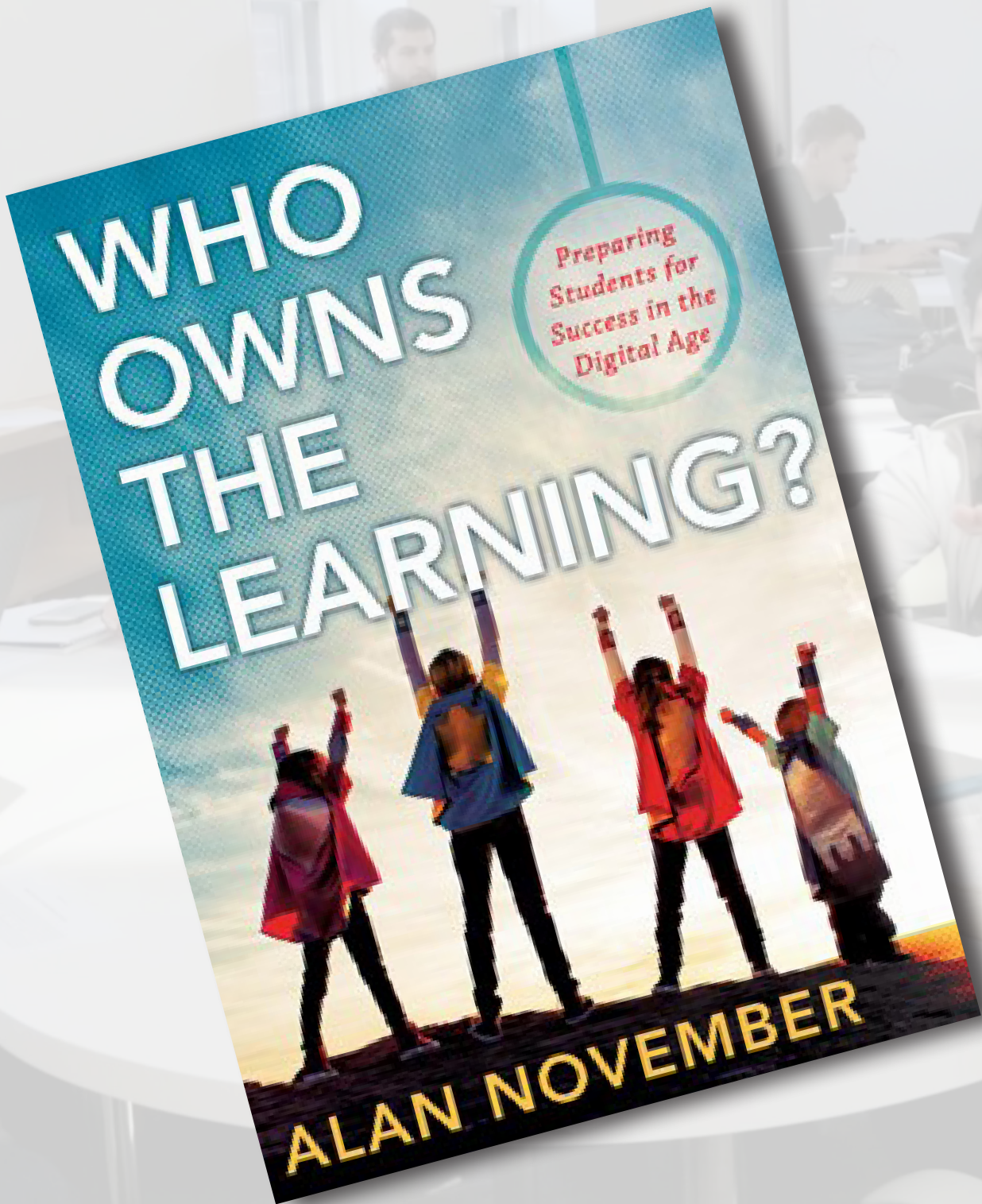



Ownership of learning *physics*?

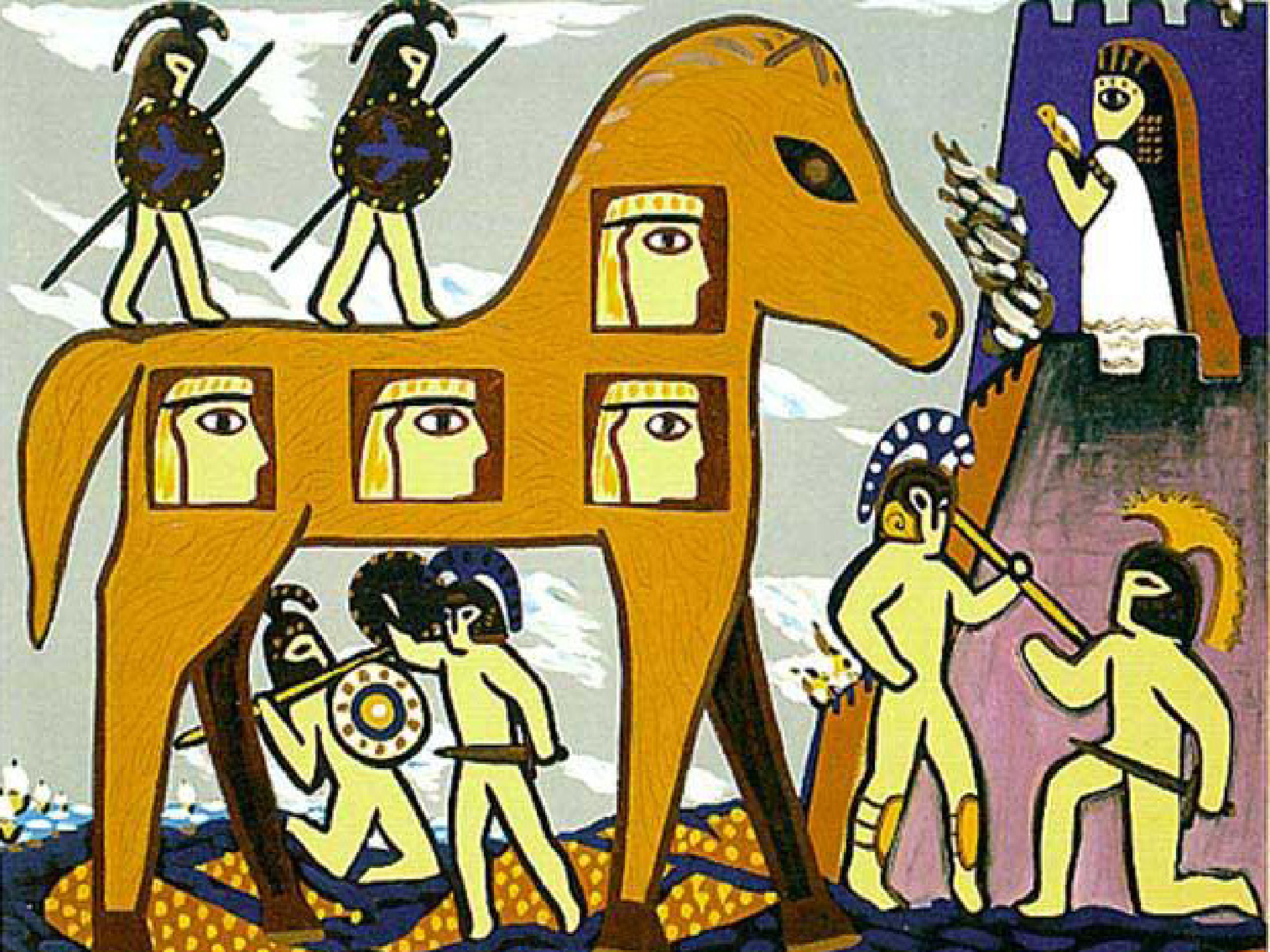



team & project-based approach





1 design

2 approach



1 design

2 approach

3 results

A group of students in a classroom or lab setting, working on laptops and discussing a project. The scene is brightly lit with large windows in the background. Several students are seated at tables, some looking at laptops, others in conversation. One student in the foreground is gesturing while talking to another. The overall atmosphere is collaborative and focused.

Four tracks, all modeled after standard course for majors



Four tracks, all modeled after standard course for majors

(don't satisfy needs of non-majors)



Need to:

- **align goals to students' needs and expectations**
- **change the approach**
- **redesign the learning space**

Setting learning goals

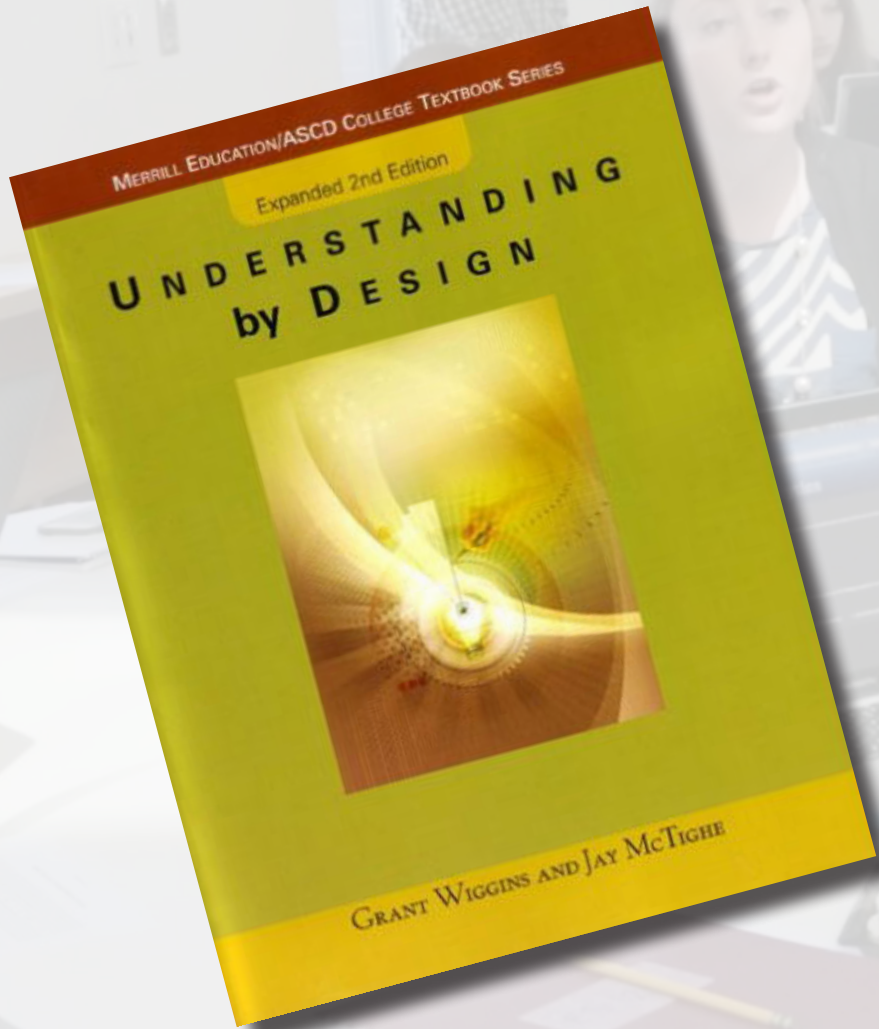

Grant Wiggins and Jay McTighe, *Understanding by Design* (Prentice Hall, 2001)

Backward design

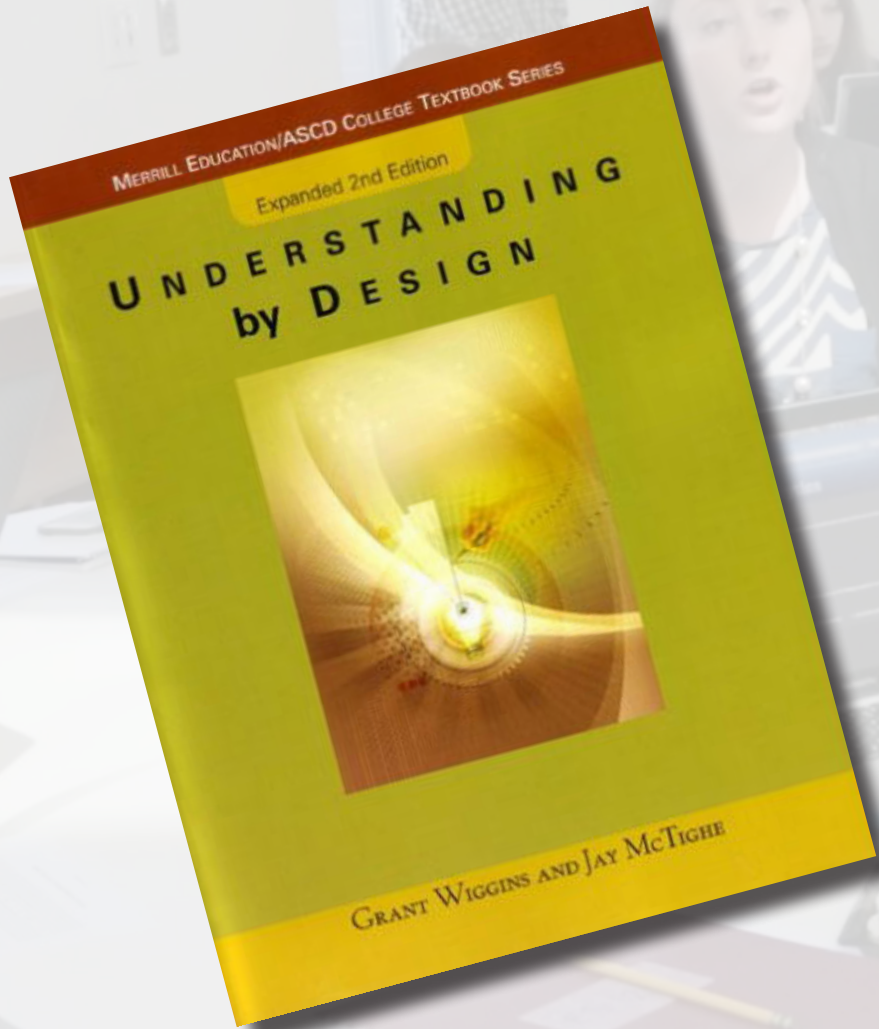

**desired
outcomes**

Grant Wiggins and Jay McTighe, *Understanding by Design* (Prentice Hall, 2001)

Backward design

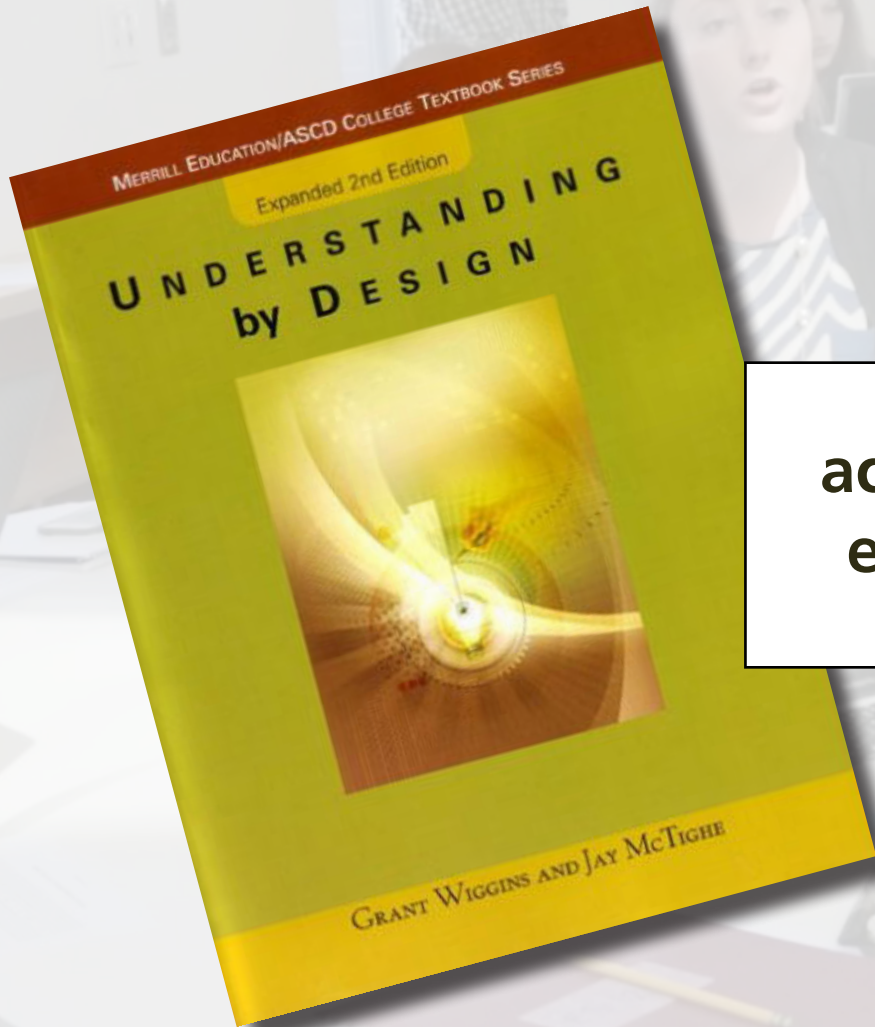

acceptable
evidence



desired
outcomes

Grant Wiggins and Jay McTighe, *Understanding by Design* (Prentice Hall, 2001)

Backward design

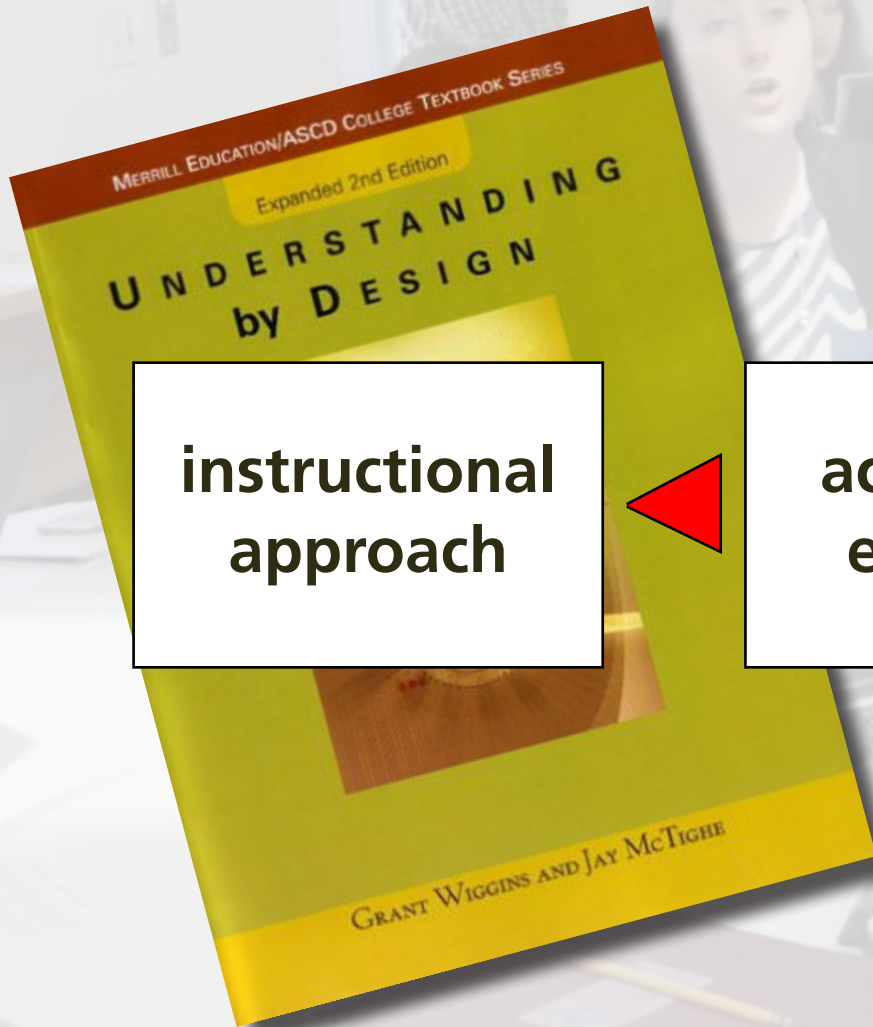

**instructional
approach**

**acceptable
evidence**

**desired
outcomes**



Grant Wiggins and Jay McTighe, *Understanding by Design* (Prentice Hall, 2001)

Backward design

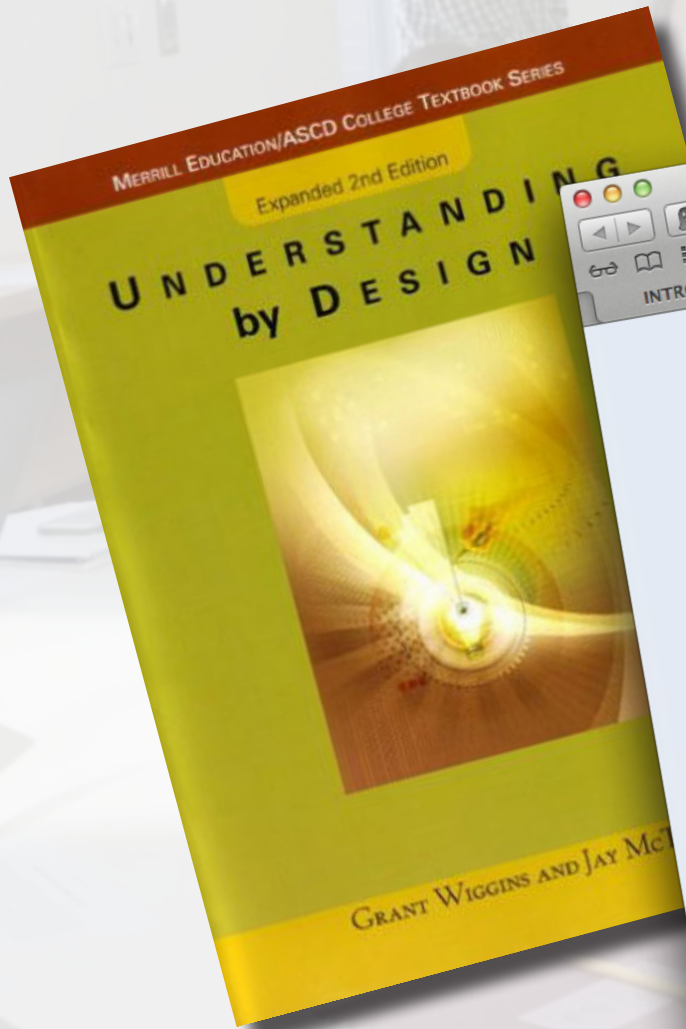
A screenshot of a web browser displaying an 'INTRO PHYSICS COURSE SURVEY' form. The browser's address bar shows the URL 'https://docs.google.com/sheet/viewform?hl=en_US&'. The form includes a title 'INTRO PHYSICS COURSE SURVEY', a thank-you message, and several questions. The first question asks for the respondent's name and email address. The second question asks for the course(s) taught that list(s) Physical Sciences, Physics 11, or Physics 15 as a prerequisite, with a text area for the course list URL. The third question asks how well prerequisite physics courses prepare students for the course, with a table of response options.

Grant Wiggins and Jay McTighe

also designed to

- **Qualitative Analysis:** The ability to analyze and to solve problems in scientific disciplines qualitatively, including estimation, and visual thinking.
- **Quantitative Analysis:** The ability to analyze and to solve problems in scientific disciplines quantitatively, including use of appropriate tools, quantitative solving, and experimentation.
- **Diagnosis:** The ability to identify and resolve problems within complex identification, formation and testing of a hypothesis, and recommending solutions.
- **Design:** The ability to develop creative, effective designs that solve creation, problem formulation, application of other competencies, balance and which integrate knowledge, beliefs and modes of inquiry from multiple perspectives.
- **Teamwork:** The ability to contribute effectively in a variety of roles while respecting everyone's contributions. You will develop communication, questioning, listening, and identifying multiple approaches and points of view.
- **Communication:** The ability to convey information and ideas effectively to identify and address your own needs, fluency in use of communication, and to contribute positively.

competencies

COURSE GOALS

After successful completion of this course, you will be able to... (with)

- Use independent study and research to tackle a problem
- Apply the scientific method to advance your knowledge and to design
- Use a variety of techniques to get a handle on problems: represent
- perform order of magnitude estimates, use dimensional analysis
- symmetries, evaluate limits, and/or relate the problem to cases w
- Set up, solve, and interpret relevant equations
- Know how to evaluate the correctness of a solution
- Explain assumptions made in a model and know how to justify
- Analyze a system, explain why it works, and how to optimize
- Use information to build a case for a specific design or measur
- Describe how a measurement is performed and the limitations
- software to control simple experiments and accumulatio
- identify sources of uncertainty, and minimiz
- measurement in order to develo
- and presentat

course goals

content-specific goals





information transfer

faculty-centered





interaction

student-centered



1 design

2 approach



CLASS

1st exposure



ROOM

deeper understanding

1 design

2 approach



1st exposure



deeper understanding



1st exposure



deeper understanding



no lectures

no exams

1 design

2 approach



Three major components:

- **information transfer (out of class)**
- **in-class activities**
- **projects**

Information transfer

social document annotation system

nb.mit.edu

1 design

2 approach

Information transfer

6/34 105%

Navigation icons: back, forward, search, print, refresh, home, etc.

CHAPTER 29 Changing magnetic fields

any relative motion between the magnet and the loop causes the magnetic flux to change. This change in magnetic flux is changing in situations that means current is induced in the loop in some cases. ✓

▲ Evaluate result: A current is induced in the loop, but only in case 4 is a magnetic force exerted on the current. Faraday's law tells me, however, that there will be a current whenever there is a changing magnetic flux through the loop, so my answers must be correct.

29.3 Is a magnetic force exerted on the (moving) charge carriers in the loop of wire held by the magnet in Figure 29.7b?

29.3 Electric fields accompany changing magnetic fields

Example 29.2 and Checkpoint 29.3 lead to a surprising conclusion: although no magnetic force is exerted on the charge carriers in a stationary loop, a current is still induced! Figure 29.10 shows this situation in more detail. Experiments show that as a magnetic field moves past a stationary conducting rod, a charge separation and hence a potential difference develop between the ends of the rod even though no magnetic force is exerted on stationary charge carriers.

The potential difference that develops between the ends of the rod shown in Figure 29.10 is the same as that which would develop if the magnetic field were stationary and the rod were moving to the right (recall Figure 29.1). Any relative motion of rod and magnet-

2 CHAPTER 28 Magnetic fields of charged particles in motion

In this chapter we investigate further the relationship between the motion of charged particles and the occurrence of magnetic fields. As we shall see, all magnetism is due to charged particles in motion, whether moving along a straight line or spinning about an axis. It takes a moving or spinning charged particle to create a magnetic field, and it takes another moving or spinning charged particle to "feel" that magnetic field. We shall also discuss various methods for creating magnetic fields, which have wide-ranging applications in electromechanical machines and instruments.

28.1 Source of the magnetic field

As we saw in Chapter 27, magnetic interactions take place between magnets, current-carrying wires, and moving charged particles. Figure 28.1 summarizes the interactions we have encountered so far. Figures 28.1a-c show the interactions between magnets and current-carrying wires. The sideways interaction between a magnet and a current-carrying wire (Figure 28.1b) is unlike any other interaction we have encountered. The forces between the wire and the magnet are not central — they do not point directly from one

Concepts

object to the other. As we saw in Section 27.7, the magnetic force exerted on a current-carrying wire is the sum of the magnetic forces exerted on many individual moving charge carriers. Similarly the magnetic field due to a current-carrying wire is the sum of the magnetic fields of many individual moving charge carriers. Figures 28.1d and 28.1e illustrate the magnetic interactions of two charged particles moving parallel to each other (Figure 28.1e), there is, in addition to an attractive magnetic force, a (much larger) repulsive electric force. It is important to note that the magnetic interaction depends on the state of motion of the charged particles. No magnetic interaction occurs between a bar magnet and a stationary charged particle (Figure 28.1f) or between two stationary charged particles (Figure 28.1g). These observations suggest that the motion of charged particles might be the origin of all magnetism. There are two problems with this assumption, however. First, the magnetic field of a wire carrying a constant current looks very different from that of a bar magnet (Compare Figures 27.13 and 27.19). Second, there is no obvious motion of charged particles in a piece of magnetic material.

Figure 28.2a shows the magnetic field lines

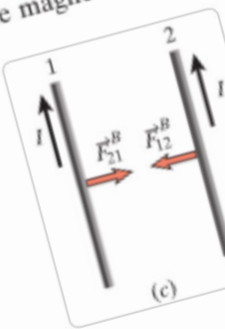
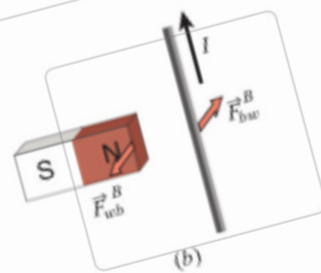
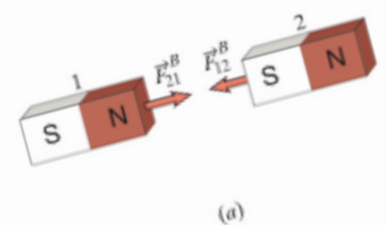

Information transfer

Student 1 – 25 Feb, 04:55PM

Yeah, this is where I'm confused. From the first paragraph: "It takes a moving or spinning charged particle to create a magnetic field..." however there is no obvious motion of charged particles in a piece of magnetic material (bar magnet for example?). How does this reconcile?

Student 2 – 26 Feb, 08:29PM

Maybe they are trying to say that there is no OBVIOUS motion, but they are moving via a current. Therefore, it meets their definition that it takes moving particles to create a magnetic field

Student 3 – 2 Mar, 09:00AM

I agree that the motion is not "obvious" in that it is not visible to the naked eye. The cause must be atomic.

Student 2 – 2 Mar, 11:37AM

Oh the answers to this question kind of address my question above - I guess there isn't a force if the particle is stationary, but since even when an object is stationary (thus no obvious motion), there is a magnetic force. It's when everything, including the particles, are stationary that there is no obvious motion.

Student 4 – 4 Mar, 01:05PM

Is there ever a situation in reality where everything, even the particles are not ...

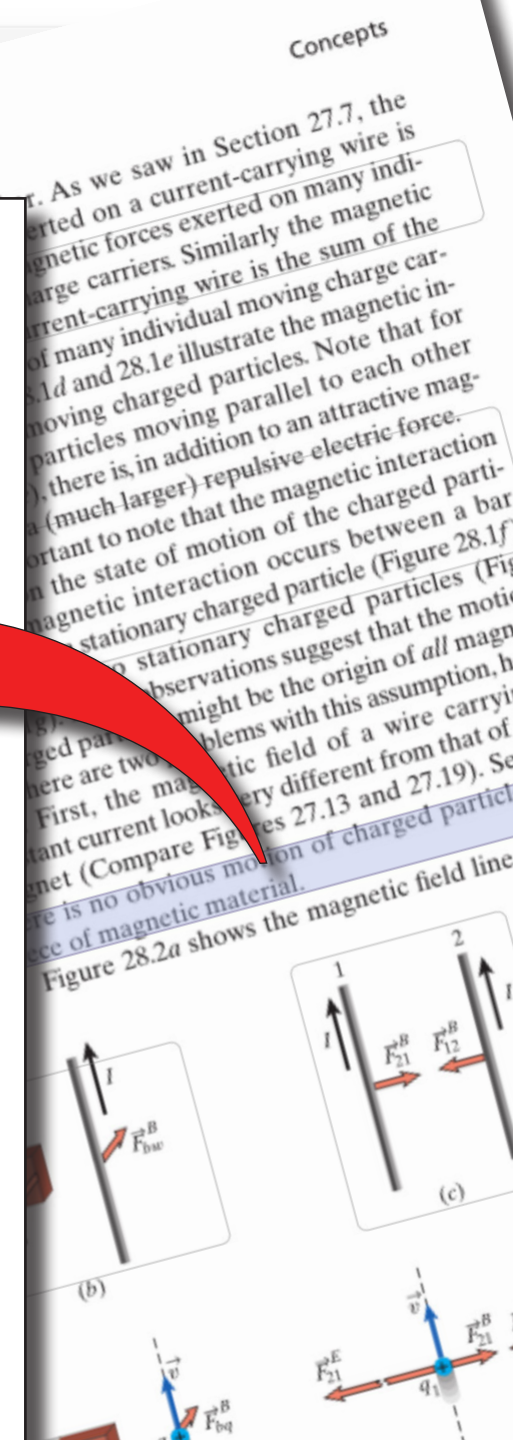

Information transfer

Student 1 – 25 Feb, 04:55PM

Yeah, this is where I'm confused. From the first paragraph, "It takes a spinning charged particle to create a magnetic field..." However, there is no obvious motion of charged particles in a piece of magnetic material (e.g., magnet, example?). How does this reconcile?

Student 2 – 26 Feb, 12:02PM

Maybe they're saying that there is no OBTAINABLE motion, but they are in fact moving via a quantum effect. Therefore, it meets their definition that it takes moving particles to create a magnetic field.

Student 3 – 2 Mar, 09:00AM

I agree that the motion is not "obvious" in that it is not visible to the naked eye. The cause must be atomic.

Student 2 – 2 Mar, 11:37AM

Oh the answers to the question and the question above - I guess there isn't a force if the particle is stationary, but since even when an object is stationary (thus no velocity motion), there is a magnetic force. It's when everything, including the particles, is stationary that there is no obvious motion.

Student 4 – 4 Mar, 01:05PM

Is there ever a situation in reality where everything, even the particles are not ...

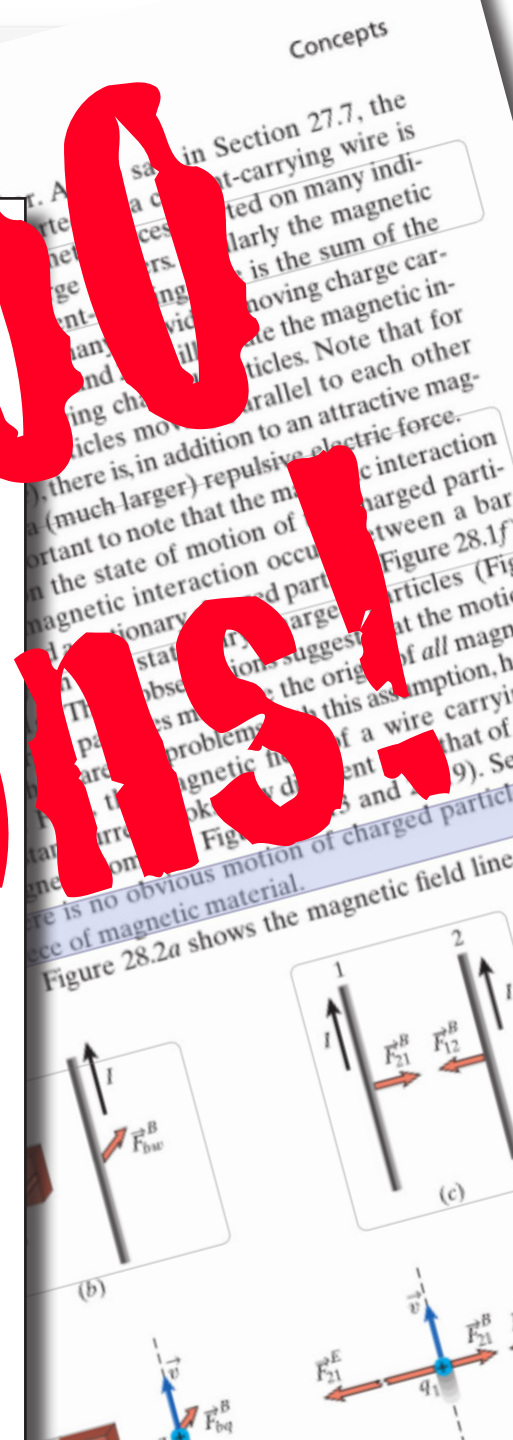

In-class activities



1 design

2 approach

In-class activities

2 weekly 3-hour class periods

1 design

2 approach

In-class activities

blend of best practices

1 design

2 approach

In-class activities

estimation

blend of best practices

1 design

2 approach

In-class activities

estimation

blend of best practices

reflection

1 design

2 approach

In-class activities

estimation

blend of best practices

reflection

readiness assurance

1 design

2 approach

In-class activities

learning catalytics

estimation

blend of best practices

reflection

readiness assurance

1 design

2 approach

In-class activities

learning catalytics

estimation

tutorials

blend of best practices

readiness assurance

reflection

1 design

2 approach

In-class activities

learning catalytics
estimation
tutorials
blend of best practices
experimental design
reflection
readiness assurance

1 design

2 approach

In-class activities

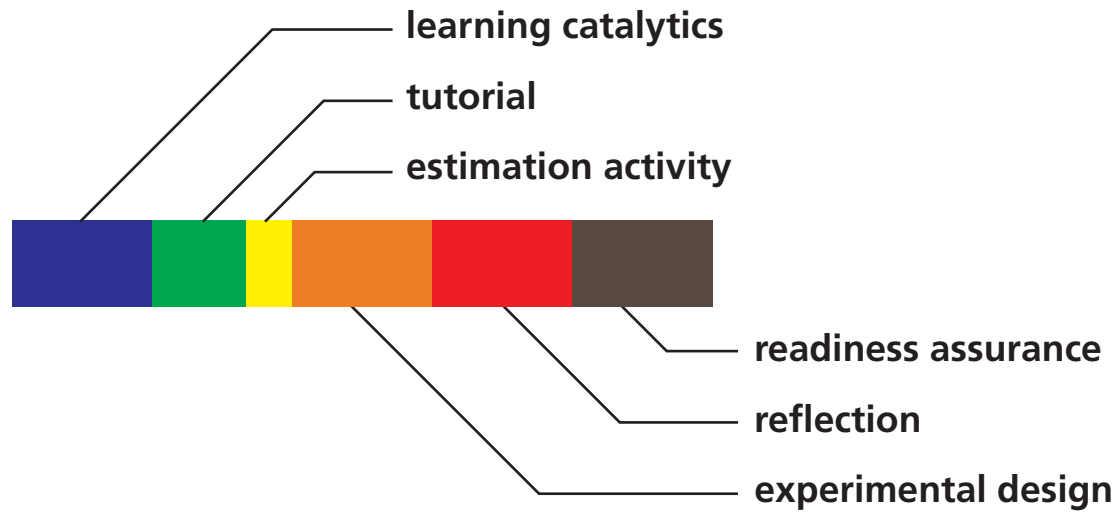

In-class activities

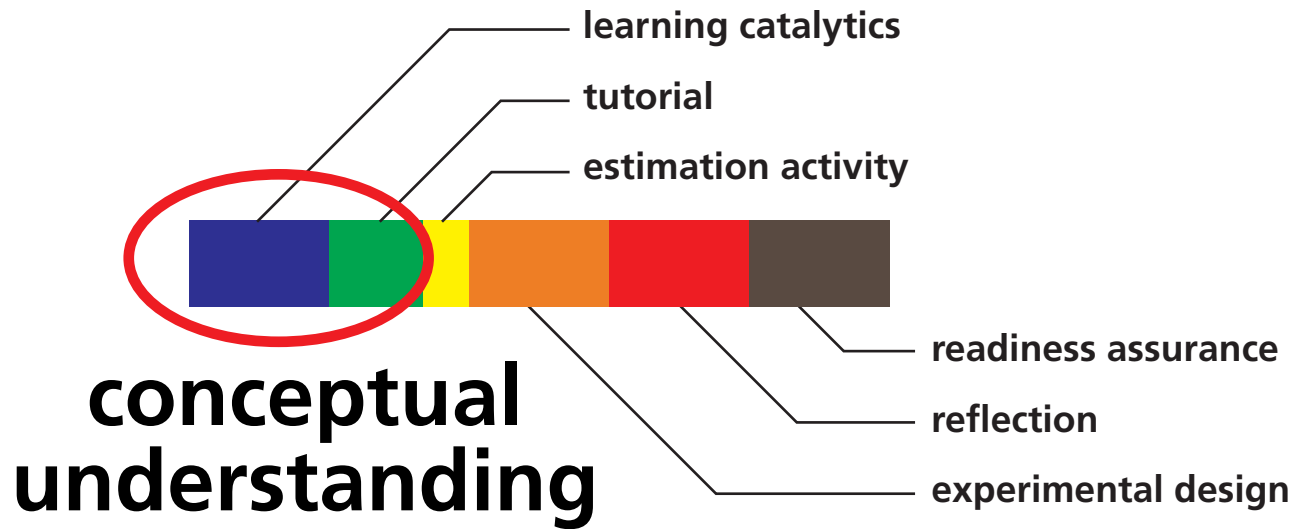

In-class activities

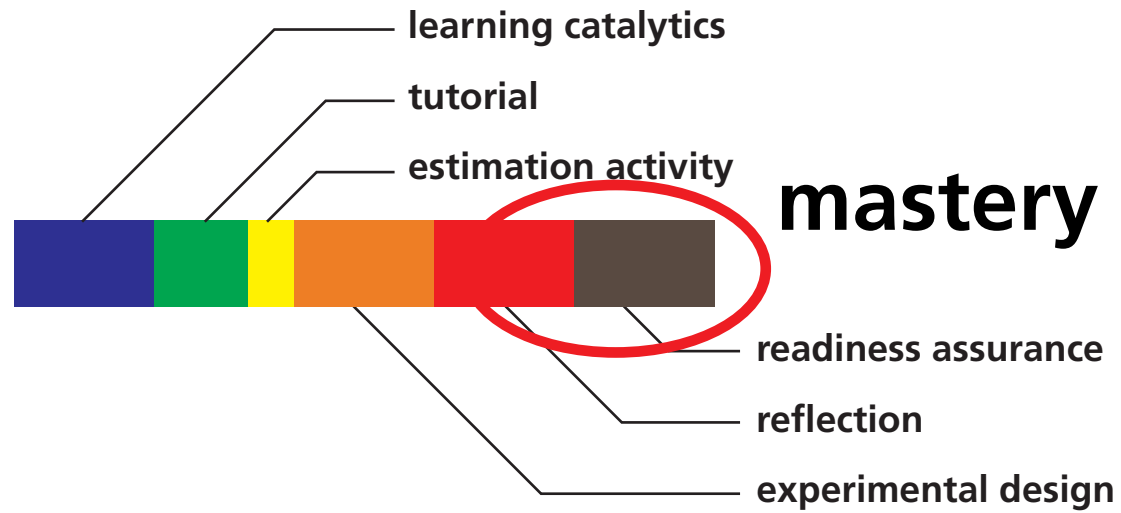

1 design

2 approach

In-class activities

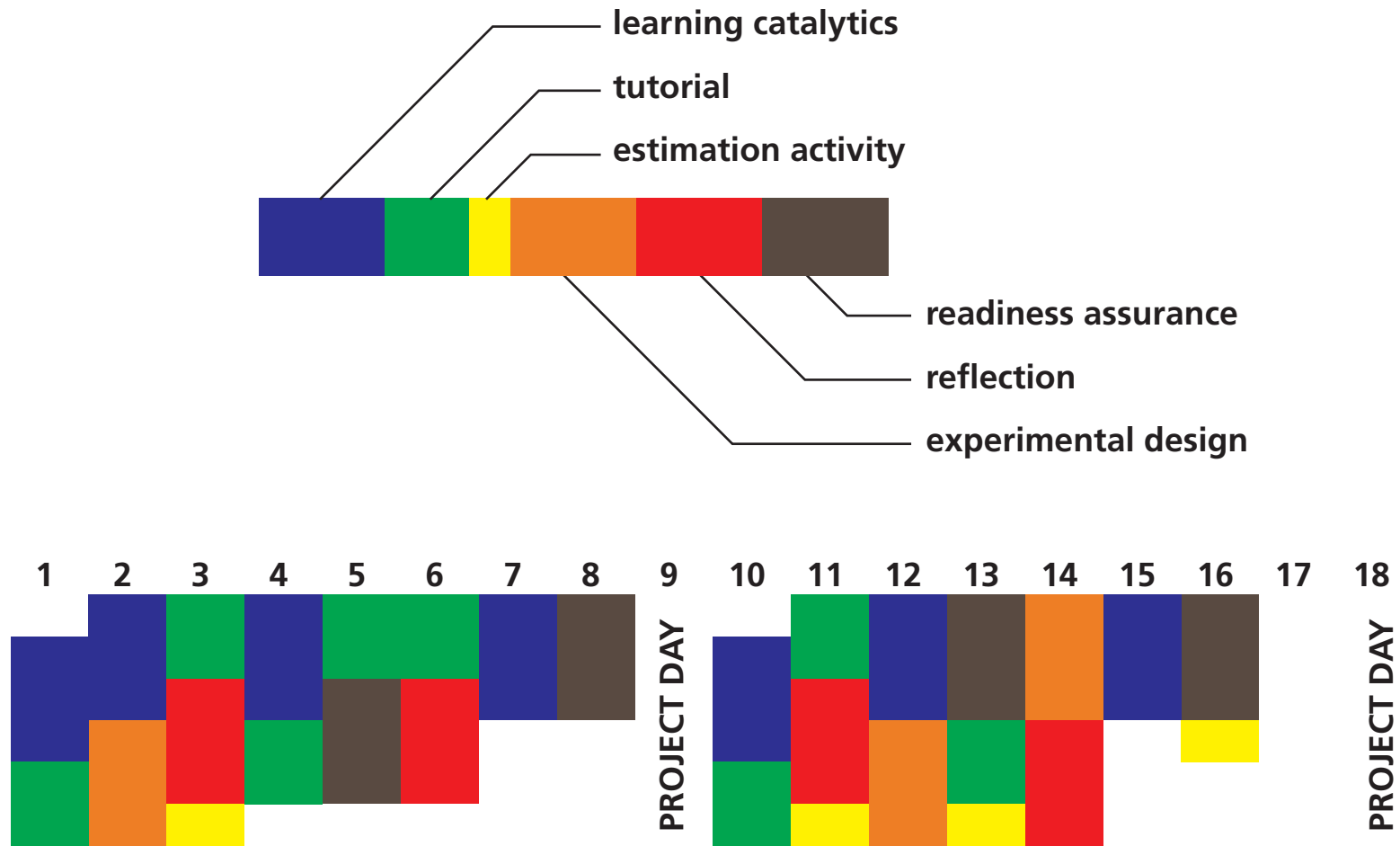

1 design

2 approach

In-class activities

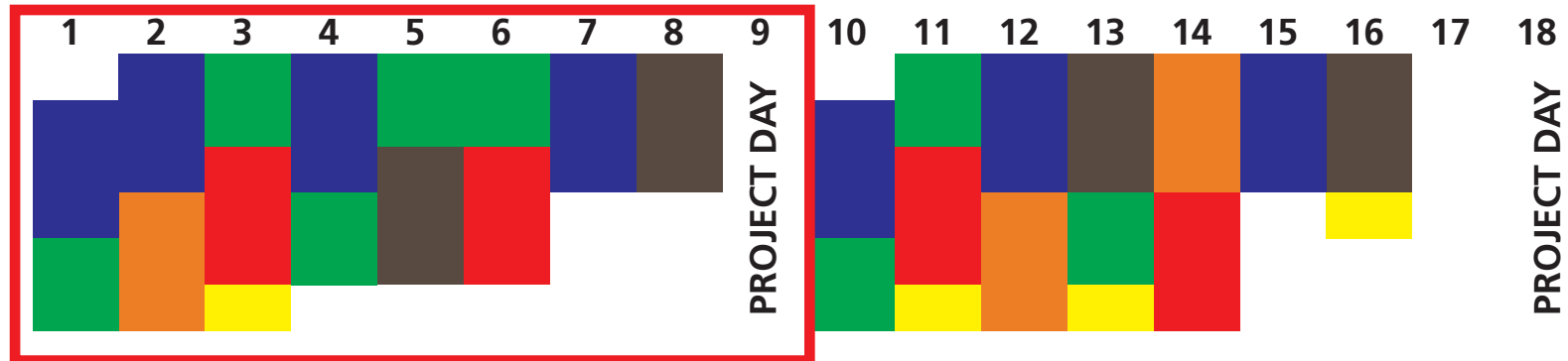
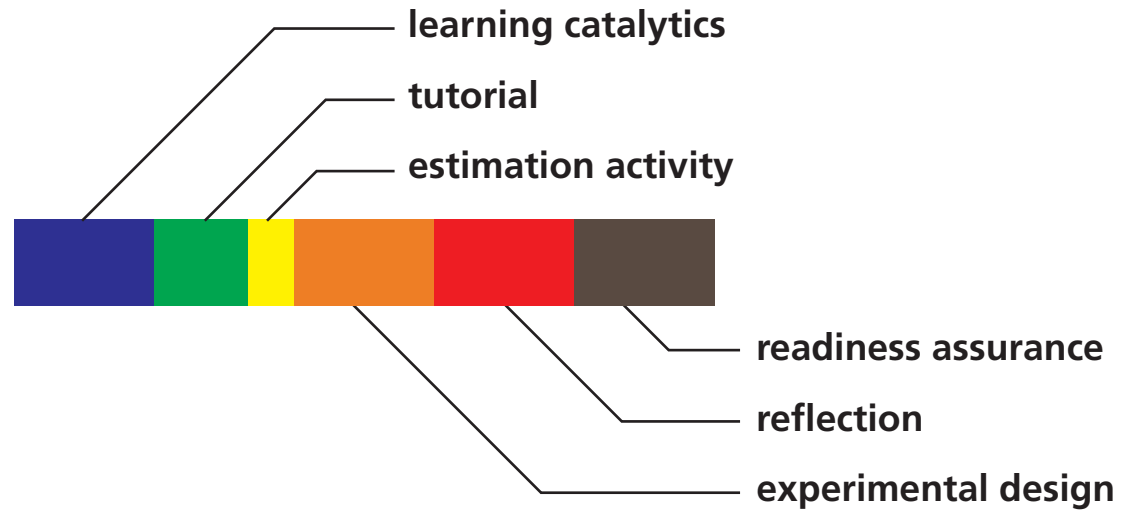

1 design

2 approach

In-class activities

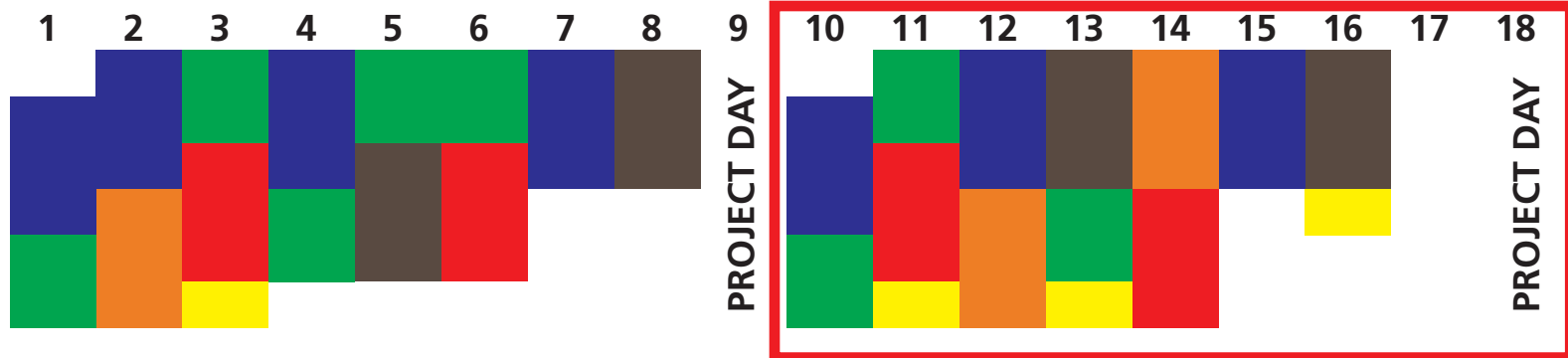
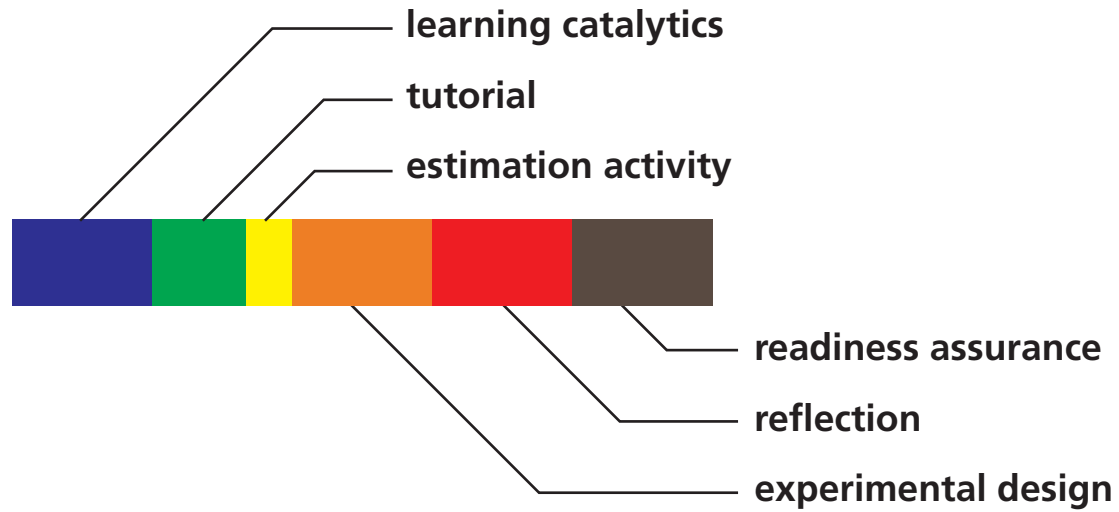

In-class activities

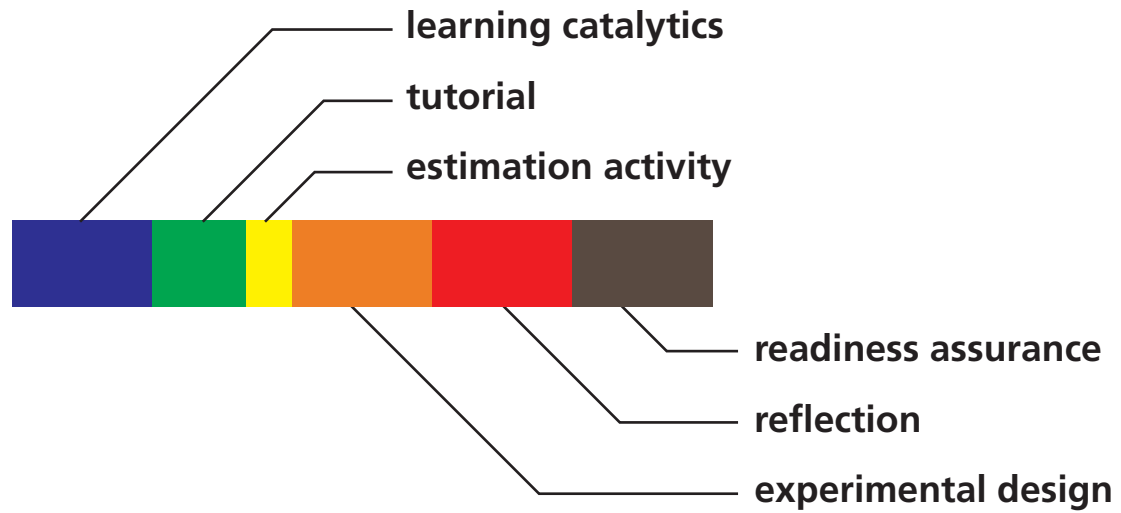

2/3 scaffolded, guided

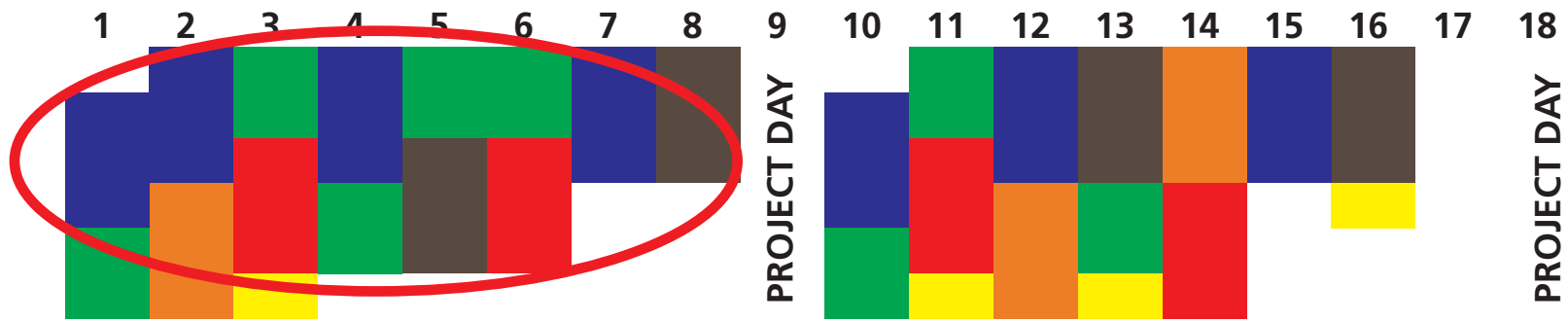

1 design

2 approach

In-class activities

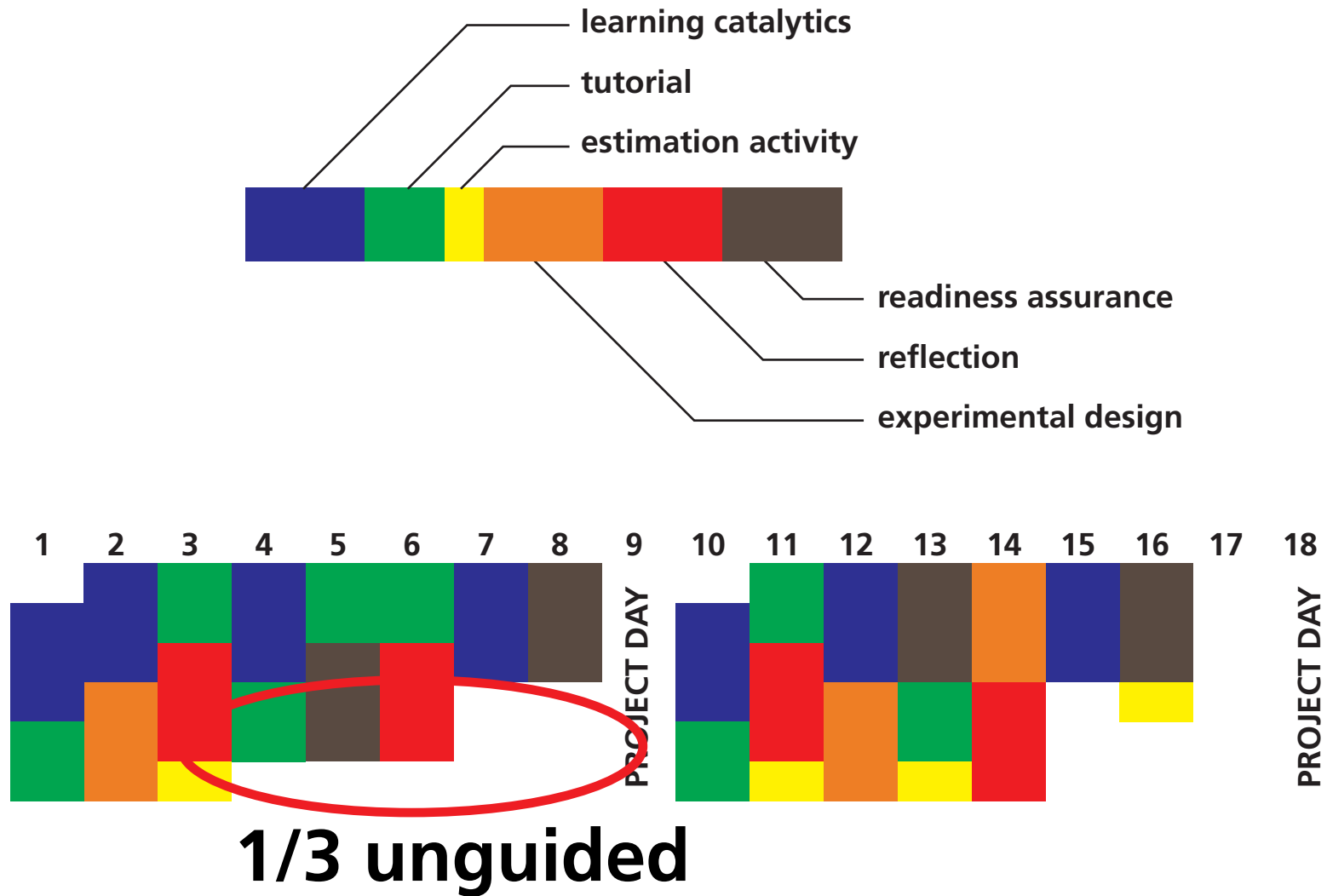

1 design

2 approach

In-class activities

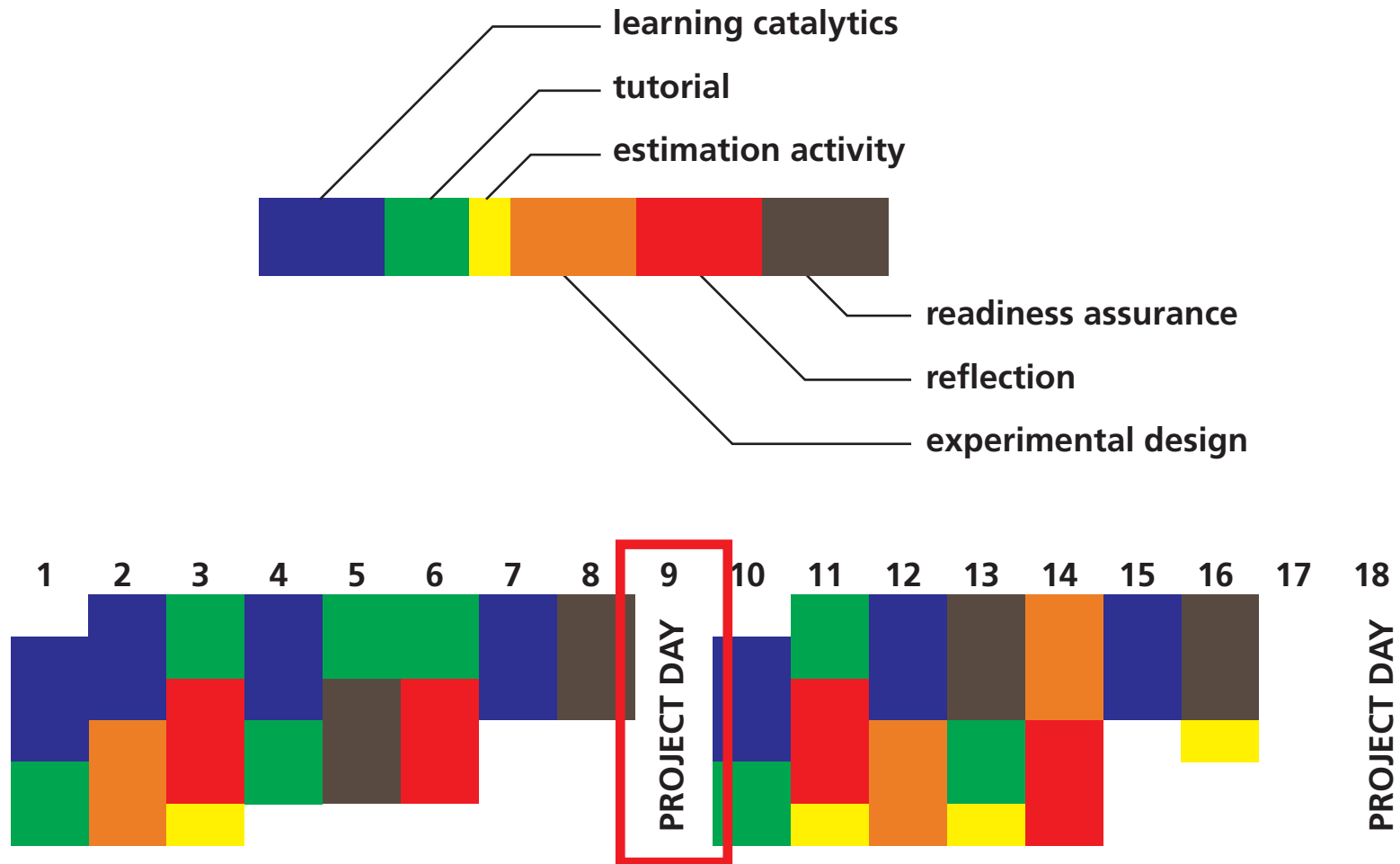

1 design

2 approach

In-class activities

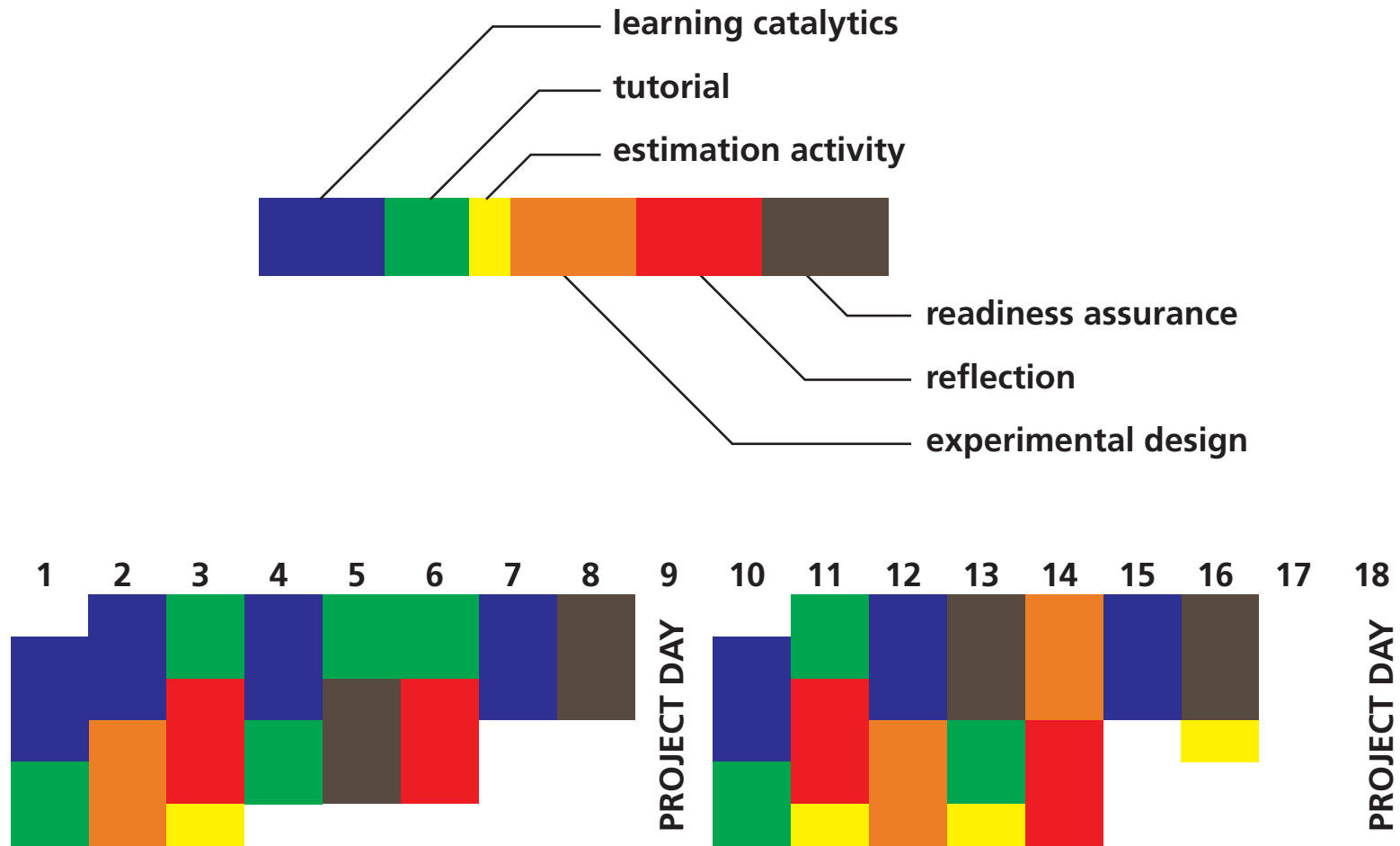

1 design

2 approach

learning catalytics

1 design

2 approach

learning catalytics

goal: develop conceptual understanding

1 design

2 approach

learning | catalytics

[Courses](#) [Participate](#) [Review](#) [Classrooms](#) [Account](#) [Institutions](#) [Purchases](#) [Users](#) [Tour](#) [Help](#)

optics i

current session: **766079** | 69 students

[Back to all lectures](#) [Stop session](#) [Review results](#) [Seat map](#) [Show floating session ID](#) [Edit](#) [Delete](#)



Jump to ▾

1

2

3

4

5

6

7

8

9

10

11

12

13

14

15



4. direction Light enters horizontally into the combination of two perpendicular mirrors as shown below.

[Deliver](#) [Show all results](#)



Indicate the direction of the incident light after it reflects off of both mirrors.



feedback & support

1 design

2 approach

learning | catalytics

[Courses](#) [Participate](#) [Review](#) [Classifications](#) [Purchases](#) [Users](#) [Tour](#) [Help](#)

current session: **766079** | 69 students

[Map](#) [Show floating session ID](#) [Edit](#) [Delete](#)

6 7 8 9 10 11 12 13 14 15

perpendicular mirrors as shown below.

[Deliver](#) [Show all results](#)

[feedback & support](#)



1 design

2 approach

learning | catalytics

[Courses](#) [Participate](#) [Review](#) [Classifications](#) [Purchases](#) [Users](#) [Tour](#) [Help](#)

current session: **766079** | 69 students

[Map](#) [Show floating session ID](#) [Edit](#) [Delete](#)

6 7 8 9 10 11 12 13 14 15

perpendicular mirrors as shown below.

[Deliver](#) [Show all results](#)

[feedback & support](#)

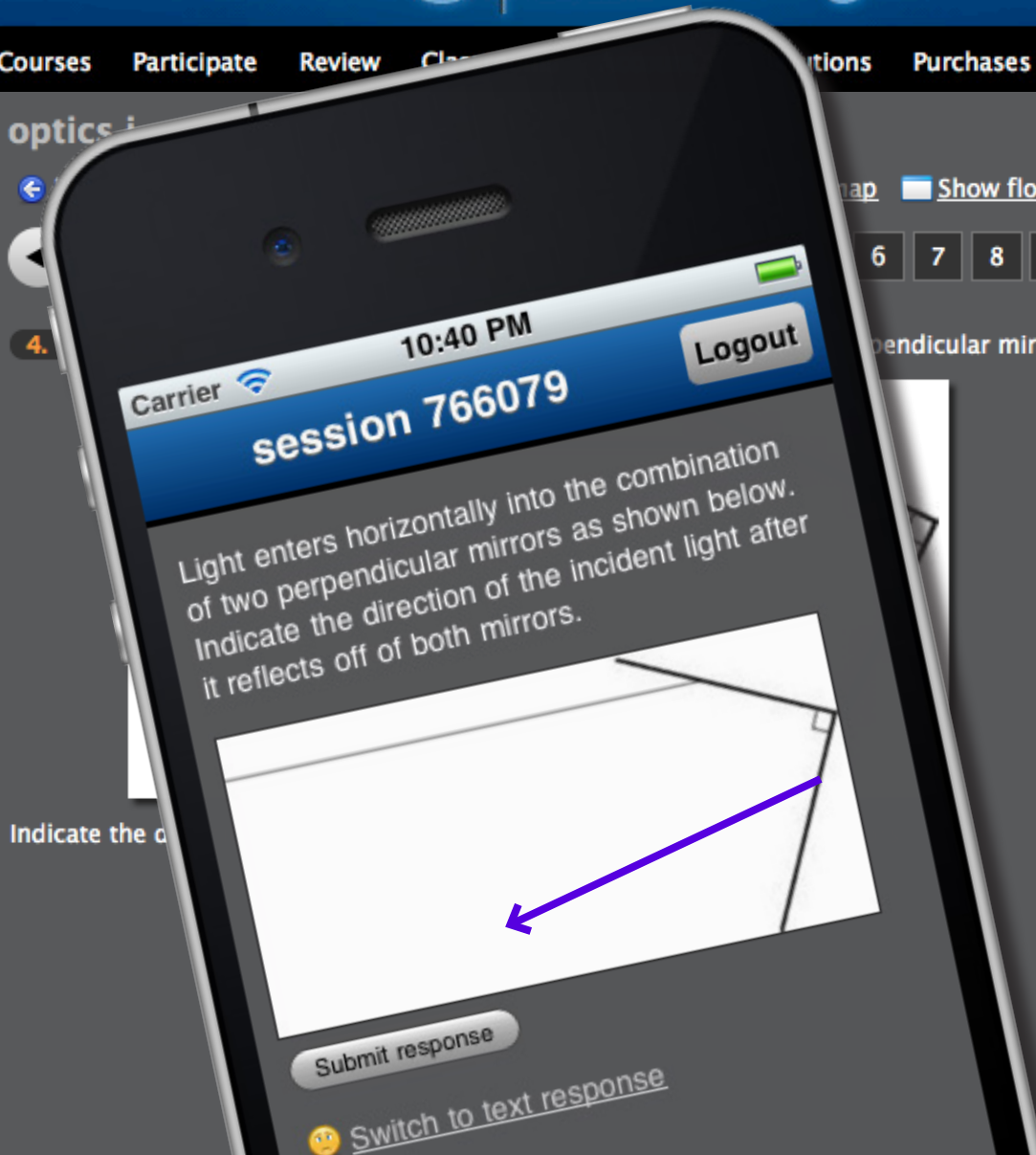

1 design

2 approach

learning | catalytics

[Courses](#) [Participate](#) [Review](#) [Classifications](#) [Purchases](#) [Users](#) [Tour](#) [Help](#)

current session: **766079** | 69 students

[Map](#) [Show floating session ID](#) [Edit](#) [Delete](#)

6 7 8 9 10 11 12 13 14 15

perpendicular mirrors as shown below.

[Deliver](#) [Show all results](#)

Round 1 [✖](#) [📊](#) [📄](#)

57 responses, 58% correct

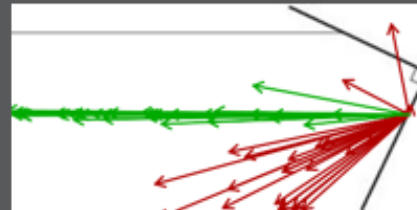

[📣 feedback & support](#)

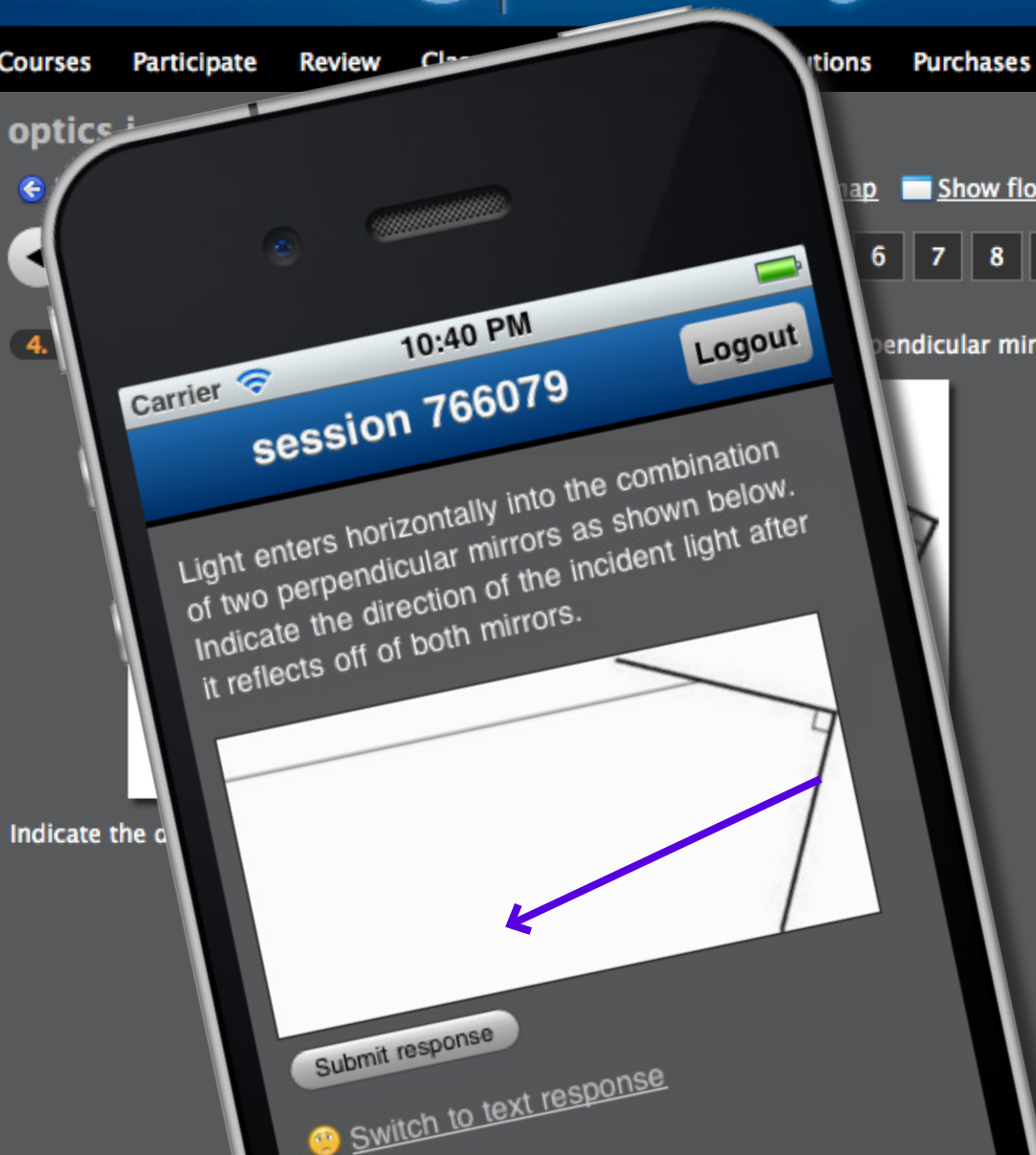

1 design

2 approach

learning | catalytics

[Courses](#) [Participate](#) [Review](#) [Classifications](#) [Purchases](#) [Users](#) [Tour](#) [Help](#)

current session: **766079** | 69 students

[Map](#) [Show floating session ID](#) [Edit](#) [Delete](#)

6 7 8 9 10 11 12 13 14 15

perpendicular mirrors as shown below.

[Deliver](#) [Show all results](#)

Round 1 [✖](#) [📊](#) [📄](#)
● 57 responses, 58% correct

Round 2 [✖](#) [📊](#) [📄](#)
● 51 responses, 73% correct

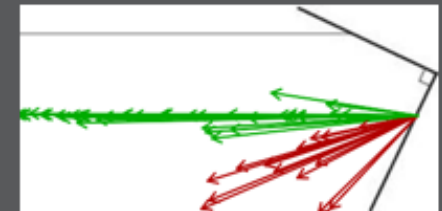
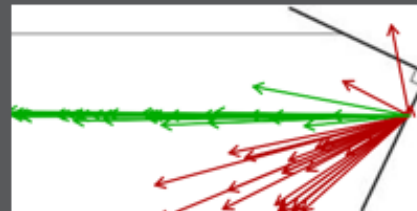

✓ 8 get it now
✗ 0 still don't get it

[📢 feedback & support](#)

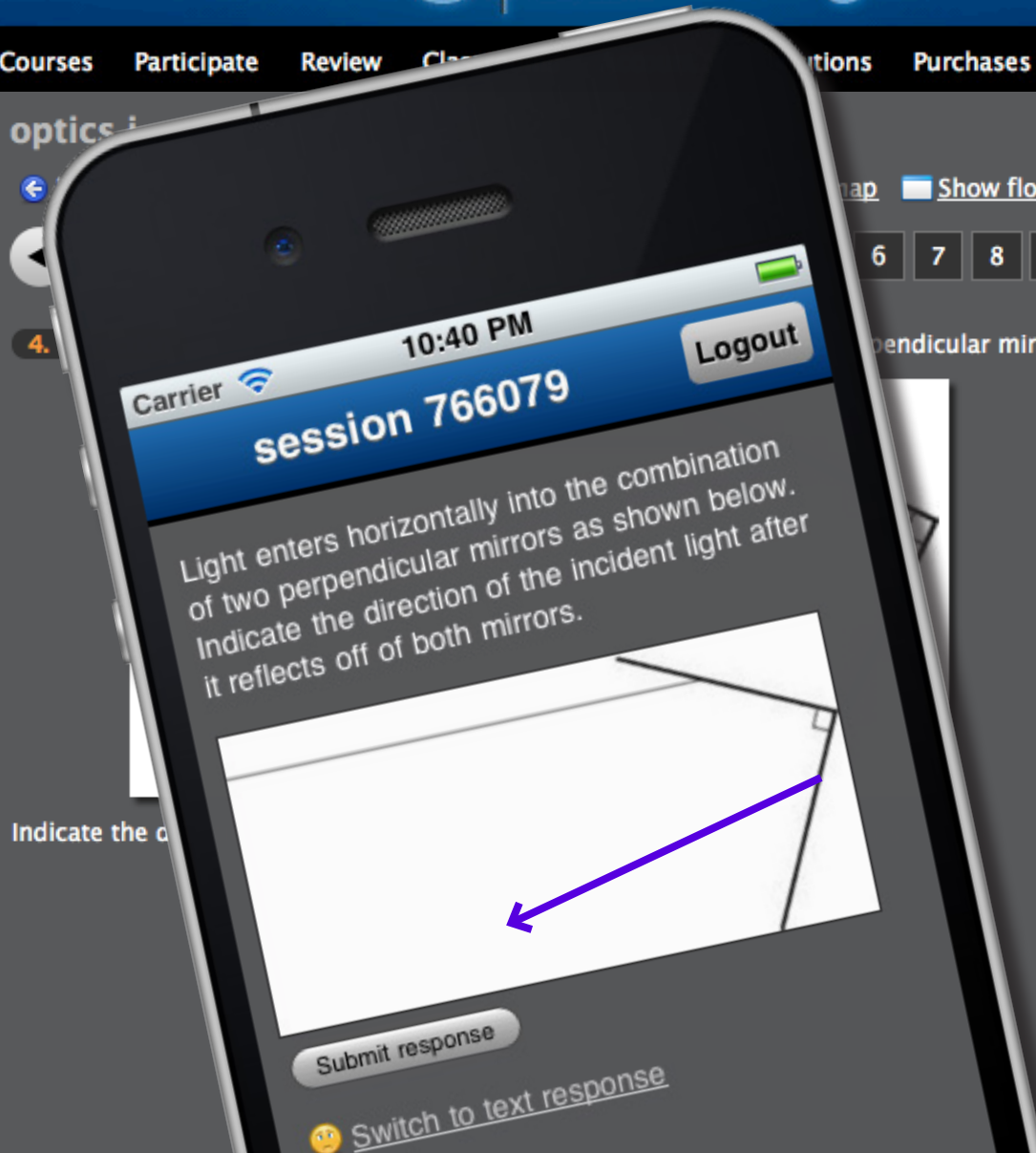

1 design

2 approach



tutorials

1 design

2 approach



tutorials

goal: address documented misconceptions

1 design

2 approach

A MODEL FOR CIRCUITS PART 2: POTENTIAL DIFFERENCE

I. Current and resistance

- A. The circuits at right contain identical batteries, bulbs, and unknown identical elements labeled X.

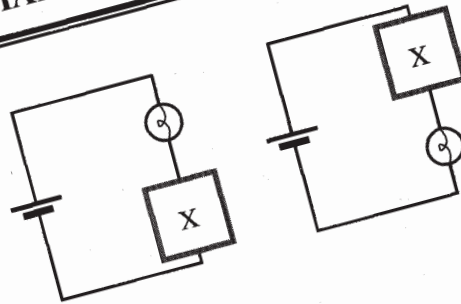

How do the bulbs compare in brightness? Explain.

In each circuit, how does the current through the bulb compare to the current through element X? Explain.

- B. The circuits at right contain identical batteries and bulbs. The boxes labeled X and Y represent different unknown elements. (Assume there are no batteries in either box.)

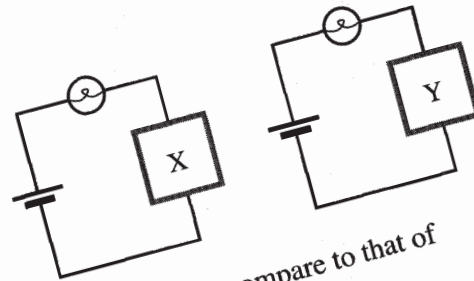

It is observed that the bulb on the left is brighter than the bulb on the right.

- Based on this observation, how does the resistance of element X compare to that of element Y? Explain.
- In each circuit, how does the current through the bulb compare to the current through the unknown element?
- In each circuit, how does the current through the bulb compare to the current through the battery?

McDermott et al., *Tutorials in Introductory Physics* (Prentice Hall, 2002)



brightness

A MODEL FOR CIRCUITS PART 2: POTENTIAL DIFFERENCE

I. Current and resistance

A. The circuits at right contain identical batteries, bulbs, and unknown elements labeled X.

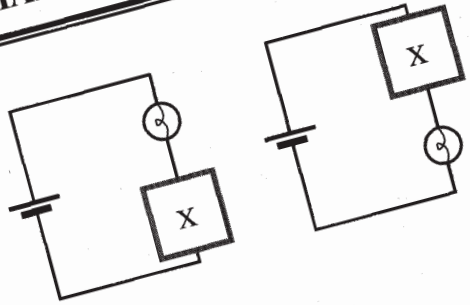

How do the bulbs compare in brightness? Explain.

In each circuit, how does the current through the bulb compare to the current through element X? Explain.

B. The circuits at right contain identical batteries and bulbs. The boxes labeled X and Y represent different unknown elements. (Assume there are no batteries in either box.)

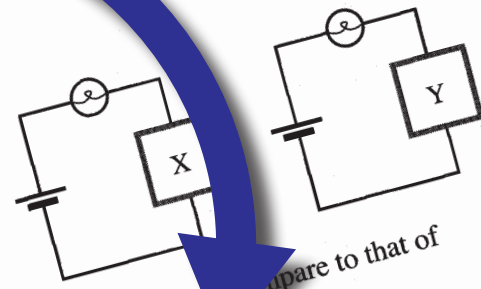

It is observed that the bulb on the left is brighter than the bulb on the right.

1. Based on this observation, how does the resistance of element X compare to that of element Y? Explain.

2. In each circuit, how does the current through the bulb compare to the current through the unknown element?

3. In each circuit, how does the current through the bulb compare to the current through the battery?



brightness

elicit
resolve
confront

McDermott et al., *Tutorials in Introductory Physics* (Prentice Hall, 2002)



estimation activity

1 design

2 approach



estimation activity

goal: develop qualitative reasoning skills

1 design

2 approach

AP50b Spring 2013

Estimation Activity 2

M March 11

Instructions: estimate (not guess!) the quantities below to the nearest order of magnitude. The first team to correctly enter all values wins.

1. Design a solenoid that can generate the same amount as the Earth's magnetic field.
2. How much current can one wearing a silver bracelet generate by walking in front of a microwave? (Assume you are wearing thick layer of clothes and your arms/bodies somehow act as insulators)
3. Estimate the flux of the Earth's magnetic field through the top of the table you are working on now.
4. Estimate the time for a radio signal to travel around the Earth.
5. As an undergrad in the 60s, Nobel Laureate claims to have built the "world's largest solenoid" by wrapping some copper wire around a football field 3 times and by plugging it into a car battery. What kind of currents and fields do you expect this coil generated?
6. What is the potential difference that causes a lightning strike?

"Estimate the amount of charge generated by connecting a AA battery to a large capacitor."

1 design

2 approach



experimental design activity

1 design

2 approach



experimental design activity

goal: develop experimental skills

1 design

2 approach

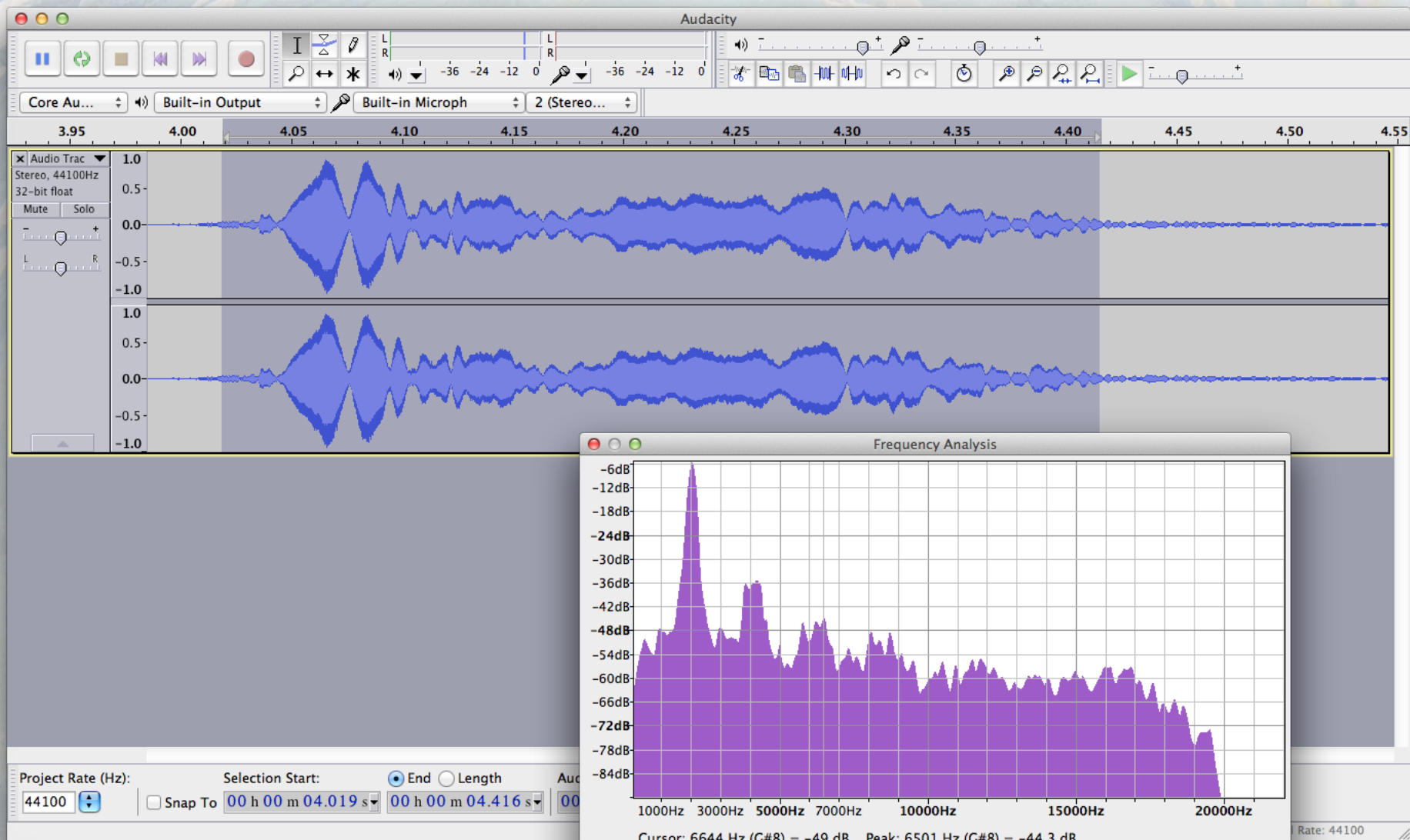

1 design

2 approach



homework reflection

1 design

2 approach



**goal: develop problem solving
and metacognitive skills**

homework reflection

1 design

2 approach

AP50b Fall 2013

Problem Set 1

due W Feb 6 in class

Instructions: as we need to quickly scan your work so we can return it before the end of class, please:

- use 8.5 x 11" paper
- no-dog ears or torn out of ring-bound notebook
- dark ink (no light pencils)
- no staples
- name on each page
- single-sided (no writing on back)
- leave margins blank

1. **Ink-Jet Printing.** In an inkjet printer, letters are built up by squirting drops of ink at a piece of paper from a rapidly moving nozzle. The ink drops leave a nozzle and travel toward the paper, passing through a charging unit that gives each drop a positive charge by removing some electrons from it. The drops then pass between parallel deflecting plates where there is a uniform vertical electric field (to be discussed in Chapter 23). Estimate the number of atoms present in a droplet of ink.
2. **Levitation.** One possible way of levitating an object might be to use the forces associated with charged objects. For example, you have two charged particles that are fixed on a vertical pole 0.5 m apart. The lower one has a fixed charge of $-3.0 \mu\text{C}$. The upper one has a charge q_A that can be adjusted. A 30-mg particle with a charge of $+8.0 \mu\text{C}$ can move freely on the pole below the other two. You wish to levitate (i.e., float) this particle at a distance of 1.0 m below the lower fixed charge. What should the adjustable charge q_A be to achieve this feat?

3. **Charge Square.** Four charged particles are arranged in a square as shown in the figure to the right, with $q = 3.9 \times 10^{-4} \text{ C}$ and $a = 6.9 \text{ mm}$. What is the net force on the particle at the upper right corner due to the other three?

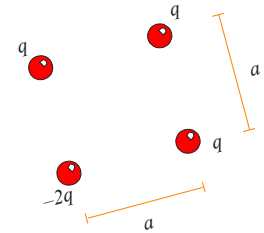

force between two concentrated ("point-like") masses is very similar in its electrostatic force between two concentrated charges. The vastly different. To illustrate this, consider the following spherical dust grains, $50 \mu\text{m}$ in diameter, with mass density are electrically neutral, free of other external levitation. Now suppose that both of n that would prevent electrons.

AP50b Fall 2013

Problem Set 1

due W Feb 6 in class

Instructions: as we need to quickly scan your work so we can return it before the end of class, please:

- use 8.5 x 11 in. paper
- no dog ears or torn corners
- dark ink (no light pencils)
- no staples
- one problem per page
- single-sided writing (no back)
- leave margins blank

phase

goal

solve (at home/individual)

skills development

reflect (in class/team)

metacognition

2. **Levitation.** In an inkjet printer, letters are formed by spraying drops of ink at a piece of paper. The ink drops leave a nozzle and travel toward the paper, passing through a charging unit that gives each drop a positive charge by removing some electrons from it. The drops then pass between two parallel deflecting plates that create a uniform vertical electric field (see Chapter 23). Estimate the number of atoms in a 100- μm -diameter ink droplet of ink.
2. **Levitation.** One possible way of levitating an object might be to use the forces associated with charged objects. For example, you have two charged particles that are fixed on a vertical pole 0.5 m apart. The lower one has a fixed charge of $-3.0 \mu\text{C}$. The upper one has a charge q_A that can be adjusted. A 30-mg particle with a charge of $+8.0 \mu\text{C}$ can move freely on the pole below the other two. You wish to levitate the particle at a distance of 1.0 m below the lower fixed charge. What should the adjustable charge be to achieve this feat?

3. **Charge Square.** Four charged particles are arranged in a square as shown in the figure to the right, with $q = 3.9 \times 10^{-4} \text{ C}$ and $a = 6.9 \text{ mm}$. What is the net force on the particle at the upper right corner due to the other three?

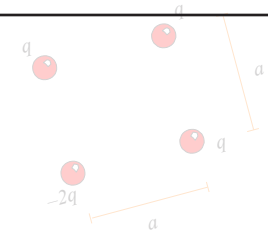

1 design

2 approach

Problem Set Rubric

The goal of the problem sets is to develop problem-solving skills, not just to test your ability to obtain the right answer. You will receive the problem sets a week before they are due. Each problem set involves both individual and team work. The rubric mirrors the 4-step procedure used in all Worked Examples in the textbook (see also Section 1.8).

Individual phase (at home): From the time you receive a problem set to the time it is due in class at 10 am, you are to work on the problem set **alone**. You can consult the textbook and online resources, but you may not consult other people, nor collaborate with your peers. Treat this stage of the problem-solving process as an open-book/open-notes exam (except that your work done at home is not evaluated on correctness—see below). It's ok to try hard and not succeed at first, but you must attempt every problem. If you get stuck, try to describe your thought process so you are prepared for a discussion with your team in class. You may only use **blue or black ink**.

Team phase (in class): On the due date of the problem set, you will work with your team in class to complete, improve, and/or correct your solutions, and plan what you need to review (if anything). During this stage, you may only use **red ink** to write on your problem sets (pens will be provided in class). After the first 45 minutes, your team will be provided with a solution set which you may use to confirm your solutions. After an additional 45 minutes, your team must submit the team's corrected problem sets together with each team member's self-evaluation and indication which problems need to be reviewed in a Learning Clinic.

Important: It is the team's responsibility to ensure that *all* team members provide complete solutions, because your team's submitted problem sets will result in a shared team score. Therefore it is your responsibility to ensure that your entire team understands the material.

Scoring

Your problem set will be evaluated on the five domains below, using the standard 0–3 scale (3 = all problems; 2 = more than 70% of the problems, 1 = more than 50% of the problems, 0 = 50% or fewer of the problems). For the first two domains we will only evaluate the work you did **before coming to class** (anything not written in red).

Getting Started

State the important information and summarize the problem. If possible, include a diagram.
Note any assumptions you're making.

Devise Plan

Write down a plan of attack before diving into the solution. Break down smaller, manageable segments. Identify which physical relationships apply.

Execute Plan

Carry out your plan, explaining each step.
Articulate your thought process clearly defined, and show how it can be applied to other problems.

Evaluate

first two domains we will only evaluate the work you did **before coming to class**.

Getting Started State the important information and summarize the problem. Note any assumptions you're making.

Devise Plan Write down a plan of attack before diving into the solution. Break the problem into smaller, manageable segments. Identify which physical principles apply.

Execute Plan Carry out your plan, explaining each step in writing. You should be able to articulate your thought process at each step (including any calculations). Your diagrams should be clearly defined, and your diagrams should be labeled. If you can complete this part in class with help from your team, that's great.

Evaluate Plan Check each solution for reasonableness. There are many ways to check: use the symmetry of the solution, evaluate limiting or extreme situations with known solutions, check units, use dimensional analysis, and check the magnitude of an answer. If you get stuck on this step, ask for help in class with help from your team.

Reflection Clearly identify and explain any conceptual errors you made when you worked on the problem alone, as well as any mechanical errors you made when you completed in class.

first two domains we will only evaluate the work you did **before coming to class**.

Getting Started

State the important information and summarize the problem. Note any assumptions you're making.

4-step procedure

Devise Plan

Write down a plan of attack before diving into the solution. Break the problem into smaller, manageable segments. Identify which physical principles apply.

Execute Plan

Carry out your plan, explaining each step in writing. You should clearly articulate your thought process at each step (including any diagrams). Your diagrams should be clearly defined, and your diagrams should be labeled. If you get stuck, you can complete this part in class with help from your team.

Evaluate Plan

Check each solution for reasonableness. There are many ways to check: use the symmetry of the solution, evaluate limiting or extreme situations with known solutions, check units, use dimensional analysis, and check the magnitude of an answer. If you get stuck on this step, you can complete this part in class with help from your team.

Reflection

Clearly identify and explain any conceptual errors you made while working on the problem alone, as well as any mechanical errors you completed in class.

1 design

2 approach

first two domains we will only evaluate the work you did before coming to c

Getting Started

State the important information and summarize the problem.
Note any assumptions you're making.

individual evaluation

Devise Plan

Write down a plan of attack before diving into the solution.
Break the problem into smaller, manageable segments. Identify which physical principles apply.

Execute Plan

Carry out your plan, explaining each step in writing. You should show your work.
Articulate your thought process at each step (including any calculations).
Your work should be clearly defined, and your diagrams should be labeled. If you can complete this part in class with help from your team, that's great.

Evaluate Plan

Check each solution for reasonableness. There are many ways to check:
the symmetry of the solution, evaluate limiting or extreme cases,
compare your solution to situations with known solutions, check units, use dimensional analysis,
check the magnitude of an answer. If you get stuck on this step, ask for help in class with help from your team.

Reflection

Clearly identify and explain any conceptual errors you made.
Describe what you worked on the problem alone, as well as any mechanics you completed in class.

first two domains we will only evaluate the work you did **before coming to class**.

Getting Started State the important information and summarize the problem. Note any assumptions you're making.

Devise Plan Write down a plan of attack before diving into the solution. Break the problem into smaller, manageable segments. Identify which physical principles apply.

Execute Plan Carry out your plan, explaining each step in writing. You should show your work. Articulate your thought process at each step (including any diagrams). Your diagrams should be clearly defined, and your diagrams should be labeled. If you can complete this part in class with help from your team.

team evaluation

Evaluate Plan Check each solution for reasonableness. There are many ways to check: use the symmetry of the solution, evaluate limiting or extreme situations with known solutions, check units, use dimensional analysis, check the magnitude of an answer. If you get stuck on this step, discuss it in class with help from your team.

Reflection Clearly identify and explain any conceptual errors you made. Describe what you worked on the problem alone, as well as any mechanics you completed in class.

1 design

2 approach

social responsibility

team evaluation

Getting Started

State the important information and summarize the problem. State any assumptions you're making.

Devise Plan

Write down a plan of attack before diving into the solution. Break the problem into smaller, manageable segments. Identify when a physical principle is needed.

Execute Plan

Carry out your plan, explaining each step in writing. You should be able to explain your process at each step (including any calculations). Clearly define and label your variables. If you are unsure of a step, ask for help in class with help from your team.

Evaluate Plan

Check each solution for reasonableness. There are many ways to check: compare the symmetry of the solution, evaluate limiting or extreme situations with known solutions, check units, use dimensional analysis, and check the magnitude of an answer. If you get stuck on this step, ask for help in class with help from your team.

Reflection

Clearly identify and explain any conceptual errors you made while working on the problem alone, as well as any mechanical errors you made while working on the problem completed in class.

1 design

2 approach

2. expectations: • b/c average of displacement to time is matter, simply how much distance (measured in displacement from point A to point B) could be covered in a specific amt of time

• note: will have to remember to transfer units of velocity to the standard m/s

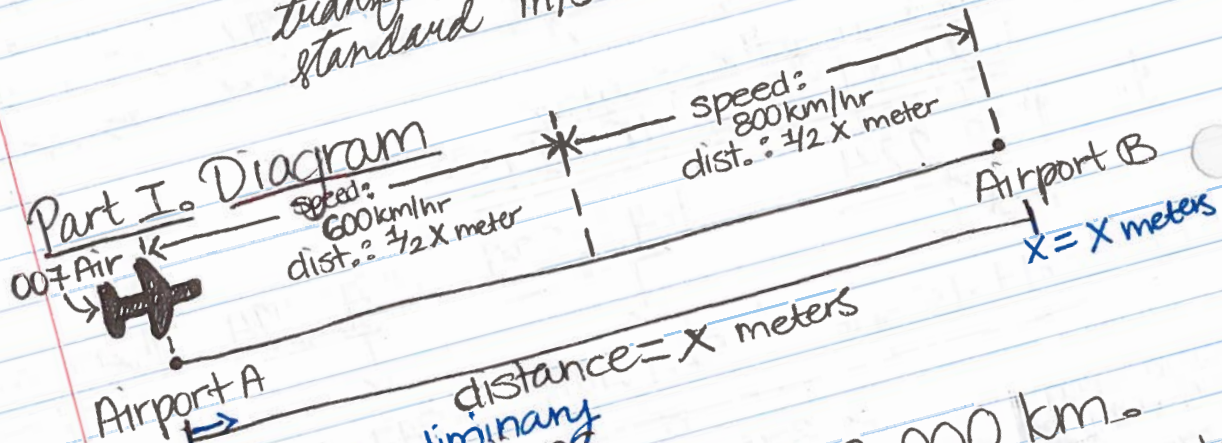

Part II: Preliminary Calculations
(arbitrary)

Assume a distance of 2,000 km.

↳ For 1,000 km, 007 Air flies at a speed of $\frac{600 \text{ km}}{\text{hr}}$ which takes $\frac{1,000 \text{ km}}{600 \text{ km/hr}} = 1 \frac{2}{3} \text{ hrs}$

↳ For the second 1,000 km, 007 Air $\text{speed} = \frac{800 \text{ km}}{\text{hr}}$ takes $\frac{1,000 \text{ km}}{800 \text{ km/hr}} = 1.25 \text{ hrs}$

calculation error

time taken = $\frac{1}{12} + \frac{1}{12} \text{ hrs.}$
= $\frac{2}{12} = \frac{1}{6} = 0.1667 \text{ hrs.}$

2. expectations: • b/c average of displacement to time is matter, simply how much distance (measured in displacement from point A to point B) could be covered in a specific amt of time

• note: will have to remember to transfer units of velocity to the standard m/s

25 pages!



Part II: Calculations
 Preliminary
 (arbitrary)

Assume a distance of 2,000 km.

↳ For 1,000 km, 007 Air flies at a speed of $\frac{600 \text{ km}}{\text{hr}}$
 which takes: $1,000 \text{ km} \left(\frac{1 \text{ hr}}{600 \text{ km}} \right) = \boxed{1 \frac{2}{3} \text{ hrs}}$

↳ For the second 1,000 km, 007 Air speed = $\frac{800 \text{ km}}{\text{hr}}$
 $1,000 \text{ km} \left(\frac{1 \text{ hr}}{800 \text{ km}} \right) = \boxed{1.25 \text{ hrs}}$

calculation error

time taken = $\frac{1}{12} + \frac{1}{12} \text{ hrs.}$
 $= \frac{2}{12} = \frac{1}{6} = 0.166 \text{ hrs.}$

2. expectations: • b/c average of displacement to time is matter, simply how much distance (measured in displacement from point A to point B) could be covered in a specific amt of time

• note: will have to remember to transfer units of velocity to the standard m/s

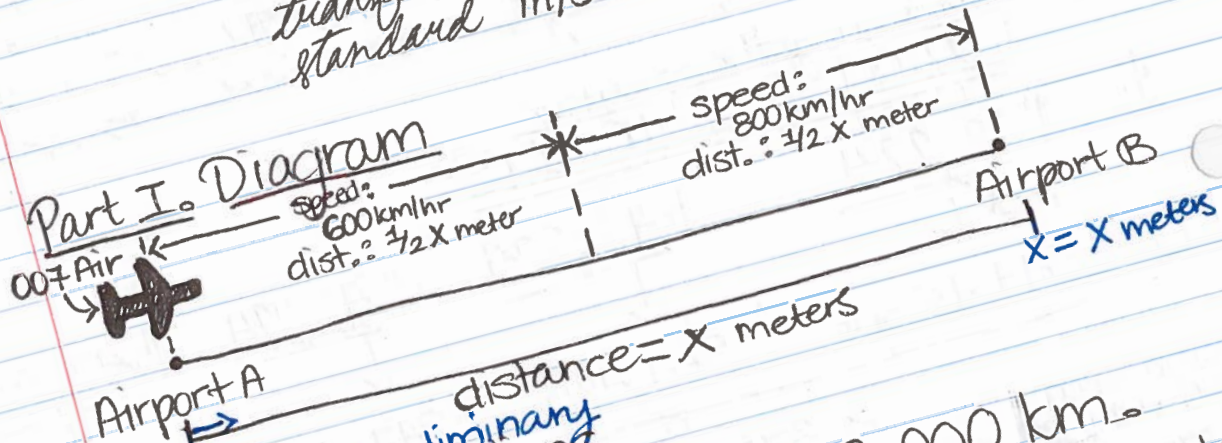

Part II. Preliminary Calculations
(arbitrary)

Assume a distance of 2,000 km.

↳ For 1,000 km, 007 Air flies at a speed of $\frac{600 \text{ km}}{\text{hr}}$ which takes $\frac{1,000 \text{ km}}{600 \text{ km/hr}} = 1 \frac{2}{3} \text{ hrs}$

↳ For the second 1,000 km, 007 Air $\frac{\text{speed} = 800 \text{ km}}{\text{hr}}$ takes $\frac{1,000 \text{ km}}{800 \text{ km/hr}} = 1.25 \text{ hrs}$

calculation error

time taken = $\frac{1}{2} + \frac{1}{2} \text{ hrs.}$
= $2 \frac{1}{2} = 2.92 \text{ hrs}$



“I was inspired and encouraged to do these problems on my own with the promise of collaborative work [the next day]”



**“I felt less pressure to find the right answer
and more freedom to explore”**

1 design

2 approach



readiness assurance activity

1 design

2 approach



goal: formative assessment
collaborative learning

readiness assurance activity

1 design

2 approach

learning catalytics

https://learningcatalytics.com/class_sessions/500941

Brian Lukoff | Harvard University | [Log out](#)

learning | catalytics

Courses Questions Classrooms Licenses Tour Help Student view

session 500941

This is the individual round; work on these questions on your own.

◀ Jump to ▼ 1 2 3 ▶

numerical question

For the circuit shown at right, calculate the potential difference between points P and Q . (Include units)

Current team: Blue Team [Change team](#) Current seat: A1 [Change seat](#) [Send a message to the instructor](#) [Join another session](#)

© 2013 Learning Catalytics LLC [Help and Support](#) | [Legal](#) | [Contact us](#) | [Institutions](#) | [Licenses](#) | [Users](#)

1 design

2 approach

learning catalytics

https://learningcatalytics.com/class_sessions/500941

Brian Lukoff | Harvard University | Log out

learning | catalytics

Courses Questions Classrooms Licenses Tour Help Student view

session 500941

This is the individual round; work on these questions on your own.

Jump to 1 2 3

numerical question

For the circuit shown at right, calculate the potential difference between points P and Q . (Include units)

9 V | Submit response

Change team Current seat: A1 Change seat Send a message to the instructor Join another session

© 2013 Learning Catalytics LLC Help and Support | Legal | Contact us | Institutions | Licenses | Users

1 design

2 approach

learning catalytics

learningcatalytics.com/class_sessions/500941

Brian Lukoff | Harvard University | Log out

learning | catalytics

Courses Questions Classrooms Licenses Tour Help

session 500941

This is the individual round; work on these questions on your own.

Jump to 1 2

numerical question

For the circuit shown at right, calculate the potential difference between points P and Q .

9 V Submit response

Current team: Blue Team Change team Current seat: A1

© 2013 Learning Catalytics LLC

Carrier 5:58 PM session 500941 Logout

This is the individual round; work on these questions on your own.

1 2 3

numerical question

For the circuit shown at right, calculate the potential difference between points P and Q . (include units)

1 design

2 approach

learning catalytics

learningcatalytics.com/class_sessions/500941

Brian Lukoff | Harvard University | Log out

learning | catalytics

Courses Questions Classrooms Licenses Tour Help

session 500941

This is the individual round; work on these questions on your own.

Jump to 1 2

numerical question

For the circuit shown at right, calculate the potential difference between points P and Q

9 V | Submit response

Current team: Blue Team [Change team](#) Current seat: A1 [Change seat](#)

[Send a message to the instructor](#)

[Join another session](#)

© 2013 Learning Catalytics LLC

Carrier (include units) 5:59 PM

Submit response

Current team: Blue Team [Change team](#)

Current seat: A1 [Change seat](#)

[Send a message to the instructor](#)

[Join another session](#)

session licenses | Users

1 design

2 approach

learning catalytics

https://learningcatalytics.com/class_sessions/500941

Brian Lukoff | Harvard University | Log out

learning | catalytics

Courses Questions Classrooms Licenses Tour Help Student view

session 500941

This is the team round. If you respond to a question, it will count for your entire team (you, Kieran Jones, and Beth Connors). Only one member of your team should respond to each question (otherwise it will count as multiple attempts).

Jump to 1 2 3

Show my team's responses

9 V	1.82 V	1.816 V
Brian Lukoff	Kieran Jones	Beth Connors

numerical question

For the circuit shown at right, calculate the potential difference between points P and Q . (Include units)

Submit response

1 design

2 approach

learning catalytics

https://learningcatalytics.com/class_sessions/500941

Brian Lukoff | Harvard University | Log out

learning | catalytics

Courses Questions Classrooms Licenses Tour Help Student view

session 500941

This is the team round. If you respond to a question, it will count for your entire team (you, Kieran Jones, and Beth Connors). Only one member of your team should respond to each question (otherwise it will count as multiple attempts).

Jump to 1 2 3

+ Show my team's responses

9 V	1.82 V	1.816 V
Brian Lukoff	Kieran Jones	Beth Connors

numerical question

For the circuit shown at right, calculate the power dissipated in the $2\ \Omega$ resistor.

Submit response

+ Show my team's responses

9 V	1.82 V	1.816 V
Brian Lukoff	Kieran Jones	Beth Connors

1 design

2 approach



1 design

2 approach

learning catalytics

https://learningcatalytics.com/class_sessions/500941

Brian Lukoff | Harvard University | [Log out](#)

learning | catalytics

Courses Questions Classrooms Licenses Tour Help Student view

session 500941

This is the team round. If you respond to a question, it will count for your entire team (you, Kieran Jones, and Beth Connors). Only one member of your team should respond to each question (your response will count as multiple attempts).

Sorry, your response to Question 3 was not correct. You can attempt this question 2 more times.

Jump to 1 2 3

[+ Show my team's responses](#)

numerical question

For the circuit shown at right, calculate the potential difference between points P and Q . (Include units)

1/3 questions attempted. 0/4 possible points so far in team round. [Score details](#)

1 design

2 approach

learning catalytics

https://learningcatalytics.com/class_sessions/500941

Brian Lukoff | Harvard University | Log out

learning | catalytics

Courses Questions Classrooms Licenses Tour Help Student view

session 500941

This is the team round. If you respond to a question, it will count for your entire team (you, Kieran Jones, and Beth Connors). Only one member of your team should respond to each question (otherwise it will count as multiple attempts).

Sorry, your response to Question 3 was not correct. You can attempt this question 2 more times.

Jump to 1 2 3

Show my team's responses

This is the team round. If you respond to a question, it will count for your entire team. Only one member of your team should respond to each question (otherwise it will count as multiple attempts).

Sorry, your response to Question 3 was not correct. You can attempt this question 2 more times.

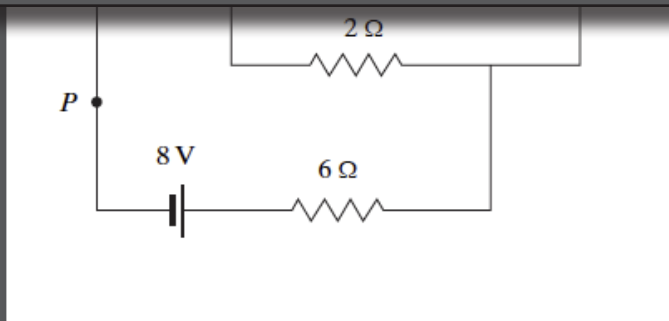

Submit response

1/3 questions attempted. 0/4 possible points so far in team round. Score details

1 design

2 approach

learning catalytics

https://learningcatalytics.com/class_sessions/500941

Brian Lukoff | Harvard University | [Log out](#)

learning | catalytics

Courses Questions Classrooms Licenses Tour Help Student view

session 500941

This is the team round. If you respond to a question, it will count for your entire team (you, Kieran Jones, and Beth Connors). Only one member of your team should respond to each question (your response will count as multiple attempts).

Your team answered Question 3 correctly!

Jump to 1 2 3

You have already answered this question correctly!

Question

For the circuit shown at right, calculate the potential difference between points P and Q . (include units)

Correct Answer
1.2 V

1 design

2 approach

learning catalytics

https://learningcatalytics.com/class_sessions/500941

Brian Lukoff | Harvard University | Log out

learning | catalytics

Courses Questions Classrooms Licenses Tour Help Student view

session 500941

This is the team round. If you respond to a question, it will count for your entire team (you, Kieran Jones, and Beth Connors). Only one member of your team should respond to each question (otherwise it will count as multiple attempts).

Your team answered Question 3 correctly!

Jump to 1 2 3

You have already answered this question correctly!

This is the team round. If you respond to a question, it will count for your entire team. Only one member of your team should respond to each question (otherwise it will count as multiple attempts).

Your team answered Question 3 correctly!

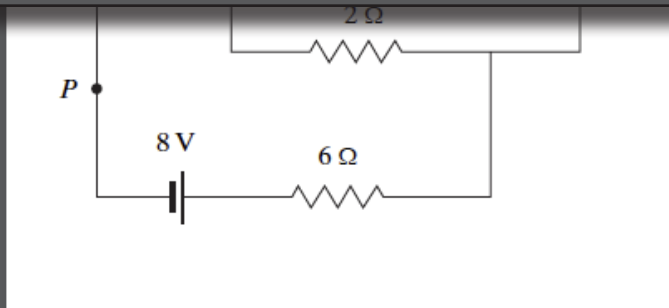

Correct Answer

1.2 V

1 design

2 approach

This is the team round. If you respond to a question, it will count for your entire team (you, Kieran Jones, and Beth Connors). Only one member of your team should respond to each question (otherwise it will count as multiple attempts).

Your team answered Question 3 correctly!



Jump to **1** **2** **3**



You have already answered this question correctly!

Question

For the circuit shown at right, calculate the potential difference between points *P* and *Q*. (include units)

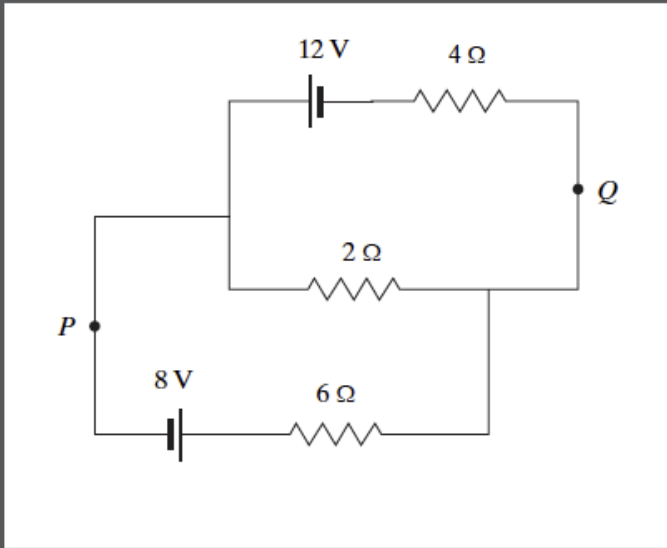

Correct Answer

1.2 V

1 question attempted, 2/4 possible points so far in team round [Score details](#)

Question	Team Result	Points
1	No response	
2	No response	
3	Correct (on attempt 2)	2
Total		2

Current team: Blue Team [Change team](#)

Current seat: A1 [Change seat](#)

[Send a message to the instructor](#)

[Join another session](#)

This is the team round. If you respond to a question, it will count for your entire team (you, Kieran Jones, and Beth Connors). Only one member of your team should respond to each question (otherwise it will count as multiple attempts).

Your team answered Question 3 correctly!



Jump to ▾ 1 2 3



You have already answered this question correctly!

Question

For the circuit shown at right, calculate the potential difference

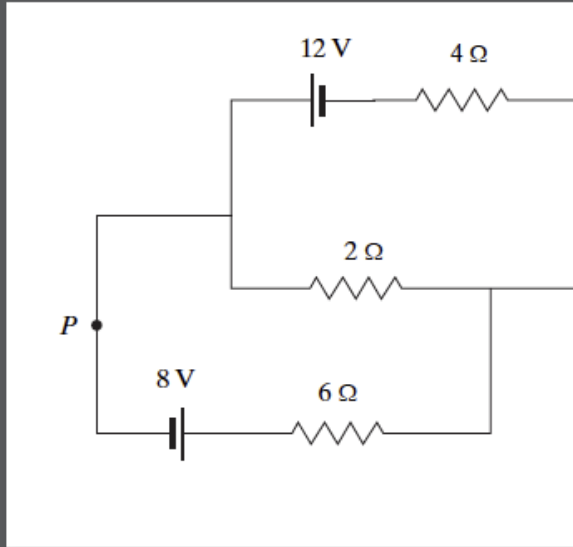

Correct Answer

1.2 V

1/3 questions attempted, 2/4 possible points so far in team round [Score details](#)

Question	Team Result	Points
1	No response	
2	No response	
3	Correct (on attempt 2)	2
Total		2

1/3 questions attempted, 2/4 possible points so far

Question	Team Result	Points
1	No response	
2	No response	
3	Correct (on attempt 2)	2
Total		2

Current team: Blue Team [Change team](#)

Current seat: A1 [Change seat](#)

[Send a message to the instructor](#)

[Join another session](#)

Projects

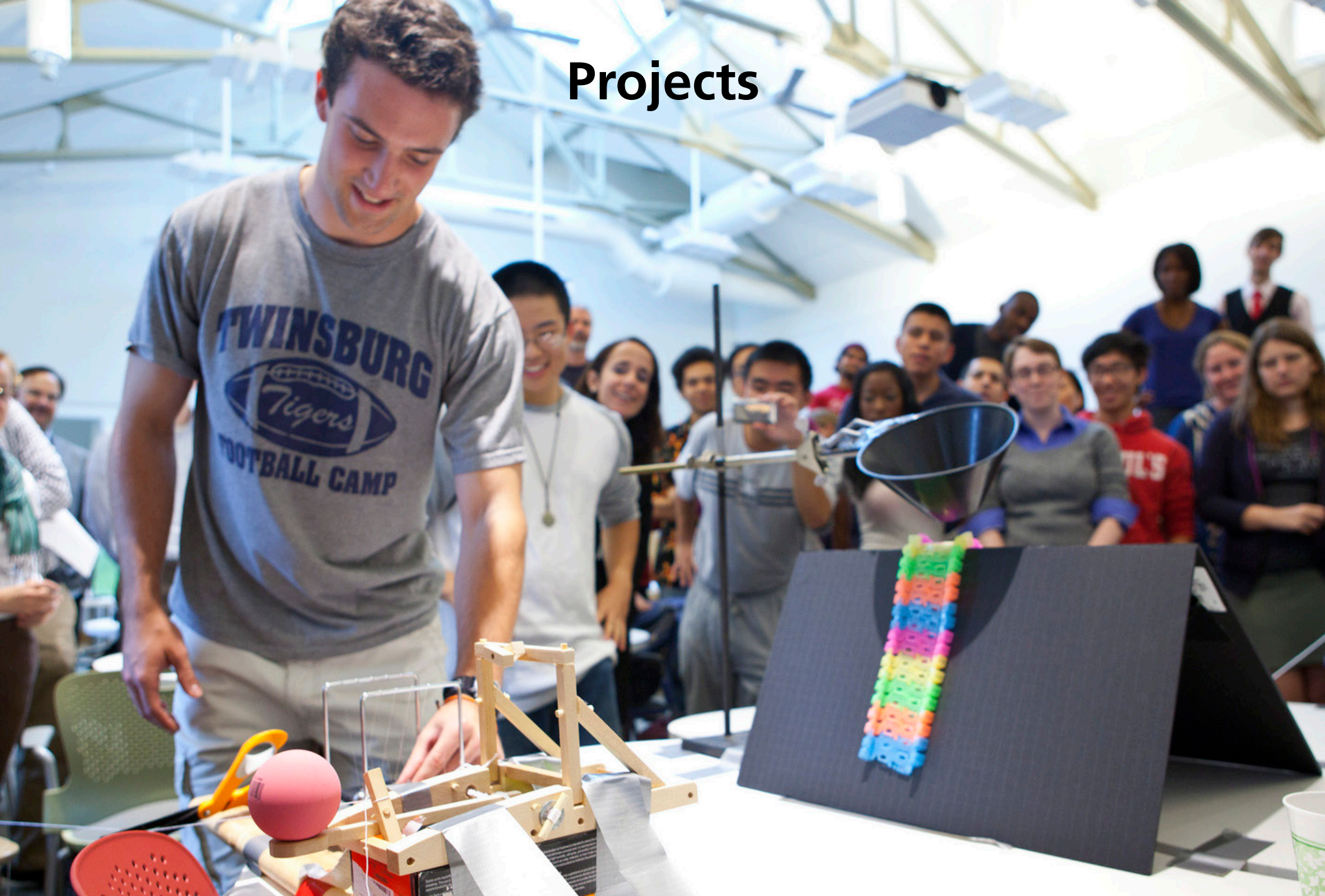

1 design

2 approach

Projects

- **3 projects/semester**
- **each project roughly one month long**
- **different team formation for each project**
- **projects not prescriptive, but open-ended**
- **3 types of project “fairs”**

1 design

2 approach

Projects

Project fair types:

- design competition
- oral presentation
- poster presentation

1 design

2 approach

Projects

To be successful, the projects must

- require practical application of skills**
- be linked to real world problems**
- have compelling narrative (help/do good)**

AP50a FALL 2013

Project Brief

Week

Week

Week 3

Week 4

Mission to Mars

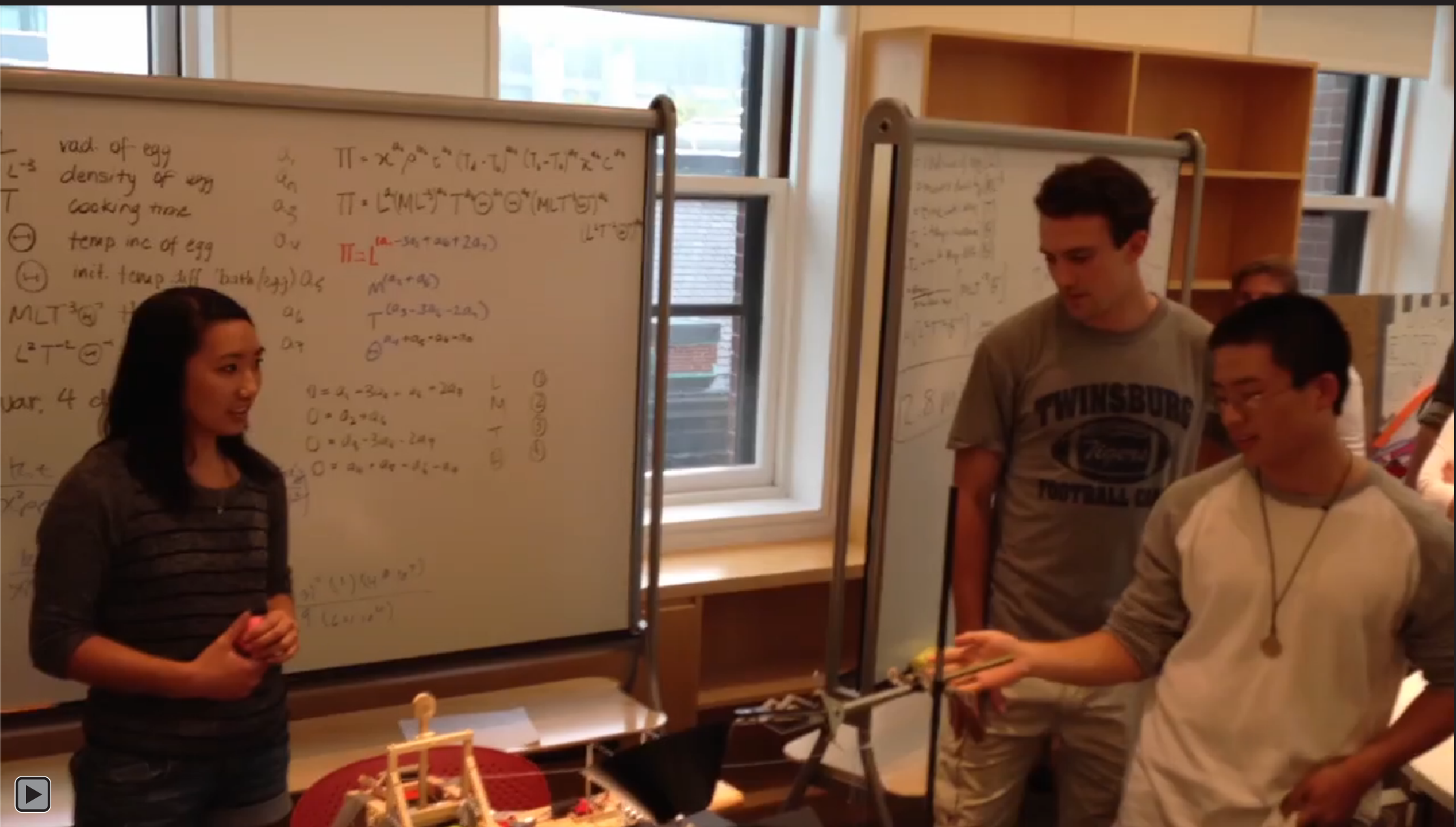

L^{-3} rad. of egg
 T density of egg
 cooking time
 \ominus temp inc of egg
 \ominus init. temp diff bath/egg
 $MLT^3\ominus$
 $L^2T^2\ominus$
 var. 4 d
 $L^2T^2\ominus$
 $X^2\ominus$
 $X^2\ominus$

a_1
 a_2
 a_3
 a_4
 a_5
 a_6
 a_7

$\Pi = \chi^a \rho^b c^c (T_b - T_e)^d (T_e - T_i)^e x^f c^g$
 $\Pi = L^a (ML^{-3})^b T^c \Theta^d \Theta^e (MLT^{-3})^f$
 $\Pi = L^{(a-3b+2f)} T^{(c+d-3e)} \Theta^{(e-f)}$
 $M^{(a+b)}$
 $T^{(a_3-3a_2-2a_1)}$
 $\Theta^{(a_4+a_5-a_6-a_7)}$

$Q = a_1 - 3a_2 - a_3 - 2a_4$
 $0 = a_2 + a_3$
 $0 = a_4 - 3a_5 - 2a_6$
 $0 = a_4 + a_5 - a_6 - a_7$

L ①
 M ②
 T ③
 Θ ④

$\frac{d^2}{dt^2} (x) = (k/m)x$
 $\frac{d}{dt} (v) = a$

(Handwritten notes on the second whiteboard, including a diagram of a structure and some text.)

1 design

2 approach

CRACK-A-THON

AP50

Wed Apr 10 • 2–5 pm • Pierce 301

1 design

2 approach



1 design

2 approach



1 design

2 approach

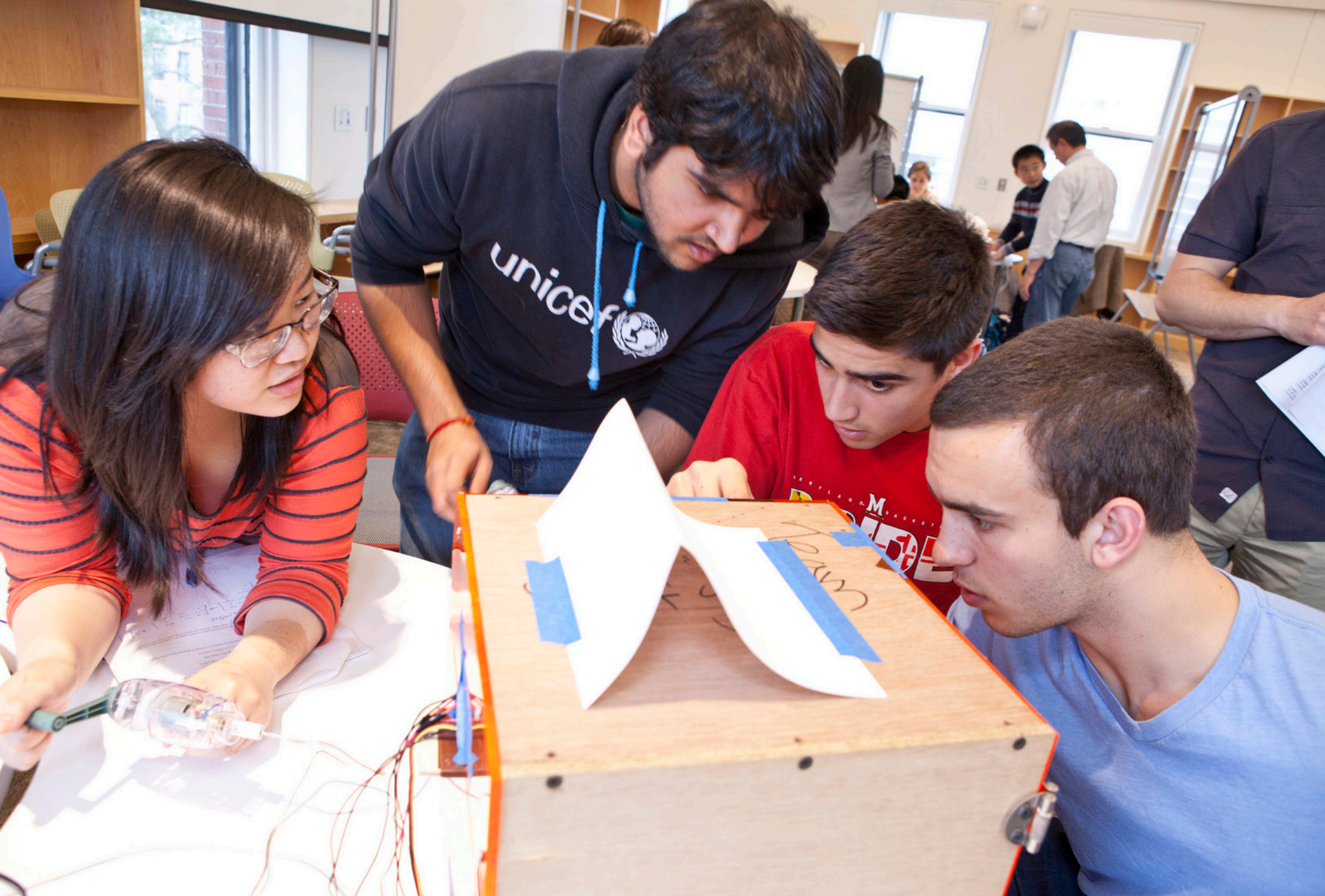

1 design

2 approach



1 design

2 approach

Peer Assessment

Team work is central in your projects and it is important to provide positive feedback to people who truly worked hard for the good of the team and to also make suggestions to those you perceived not to be working as effectively on team tasks. You may want to review the sections entitled on Teamwork and Peer Assessment in the syllabus to refresh your memory on why we stress teamwork and how to maximize the benefit from work together. Please complete the form below to assess your own contributions and those of your team members.

Complete the paper based form, then enter the data online at: <http://bit.ly/AP50Teameval>

How we will use your evaluation: In computing the (multiplicative) weight we give to your team scores, we will take into account:

1. Your team members' assessment of your contributions,
2. the quality of your self assessment (that is, how well it matches that of your team members' evaluation of your contribution), and
3. the quality of your assessment of your team members (that is, how well it matches the evaluations of that team member's contribution by the remainder of the team).

Please first complete the individual forms for each team member (including yourself), then complete the table below. When completing the table below, be sure that the **total of all relative contributions must be zero**.

		RELATIVE CONTRIBUTION						
		Total must equal ZERO						
Name		Below Average			Average	Above average		
		-3	-2	-1	0	1	2	3
Me								
Member 1								
Member 2								
Member 3								
Member 4								

Assessment

- self-directed learning
- learning goals
- teamwork
- professionalism

1 design

2 approach

Assessment

- self-directed learning — NB & problem sets
- learning goals
- teamwork
- professionalism

1 design

2 approach

Assessment

- self-directed learning — NB & problem sets
- learning goals — RAA & project reports
- teamwork
- professionalism

1 design

2 approach

Assessment

- self-directed learning — NB & problem sets
- learning goals — RAA & project reports
- teamwork — project & peer assessment
- professionalism

1 design

2 approach

Assessment

- self-directed learning — NB & problem sets
- learning goals — RAA & project reports
- teamwork — project & peer assessment
- professionalism — participation, punctuality
& engagement



1 design

2 approach

3 results

Ownership

The background is a dense, colorful network of lines and icons. The lines are primarily blue, green, and orange, forming a complex web. Various icons are scattered throughout, including social media logos like Facebook (f), Twitter (t), and YouTube (play button), as well as other symbols like a camera, a music note, a pin, a document, a star, a globe, a house, a person, a gear, a Wi-Fi signal, a paperclip, and an @ symbol. The overall theme is digital connectivity and ownership.

1 design

2 approach

3 results

Ownership

Course evaluation: 4.2/5

1 design

2 approach

3 results

Ownership

“The structure of the class made what was my least-favorite subject into one of my favorites.”

1 design

2 approach

3 results

Ownership

“The structure of the class made what was my least-favorite subject into one of my favorites. I was worried that people, including myself, would just slack off and do the bare minimum, but you really need to be on top of your readings and concepts in order to contribute to your team. GREAT CLASS!!!!!!”

1 design

2 approach

3 results

Ownership

“Dear Harvard students, this class will be unlike any class you’ve taken at Harvard, and it will, hopefully, shift the entire foundation upon which you’ve based your education. I truly believe everyone should take this course; prepare to take full ownership of your learning.”

1 design

2 approach

3 results

Ownership

Attendance: 94% (AP50a), 97% (AP50b)

1 design

2 approach

3 results

Ownership

Attendance: 94% (AP50a), 97% (AP50b)

3 hours and they don't *leave!*

1 design

2 approach

3 results

Ownership

"I don't think I am well enough to make it through class. I feel terrible because I don't want to let my team down by not being there, but I don't think I'd be very helpful in my current state."

(via email)

1 design

2 approach

3 results

Conceptual Mastery

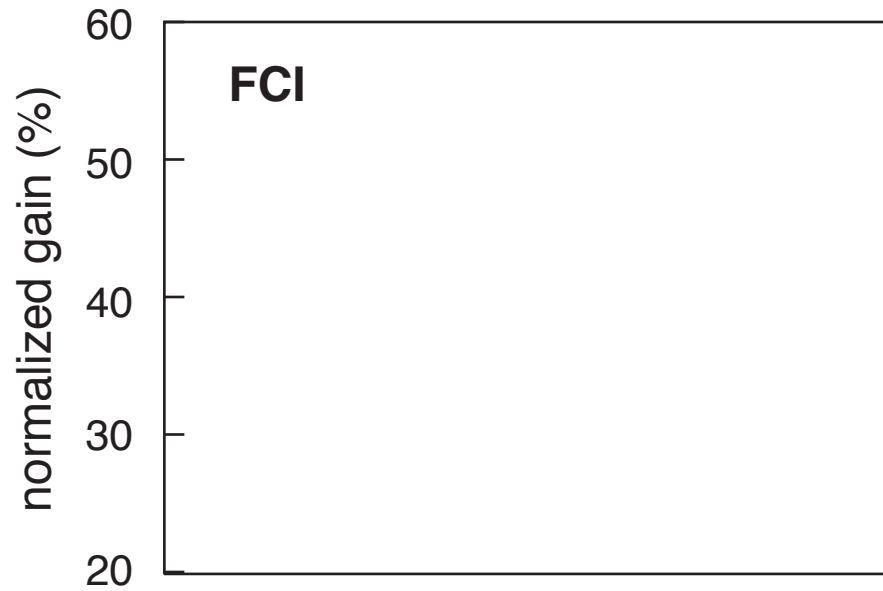

1 design

2 approach

3 results

Conceptual Mastery

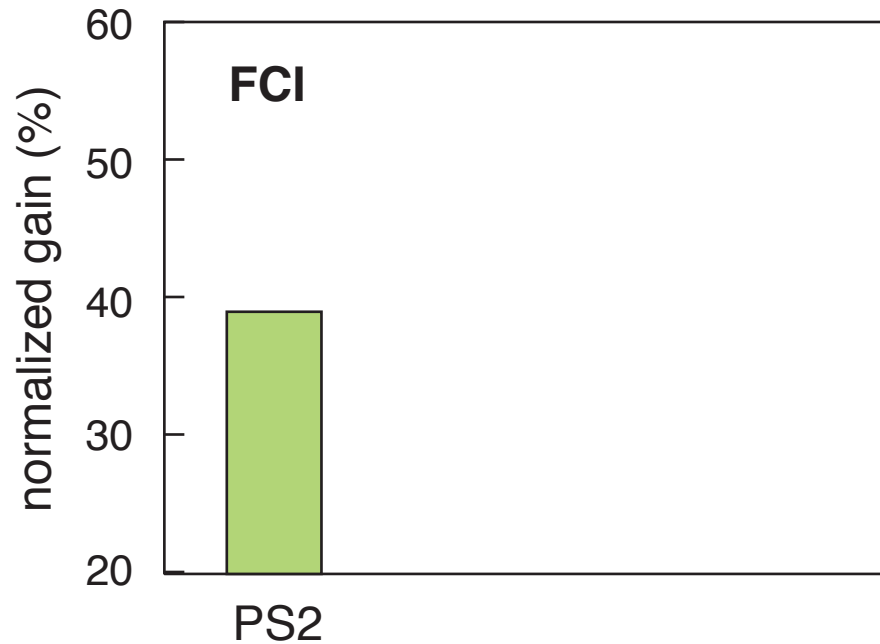

Conceptual Mastery

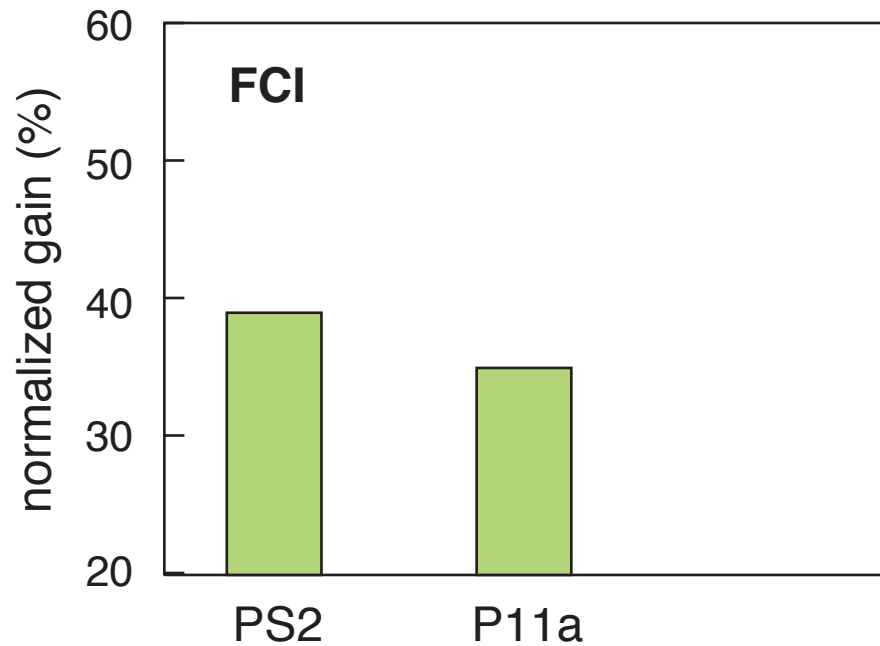

Conceptual Mastery

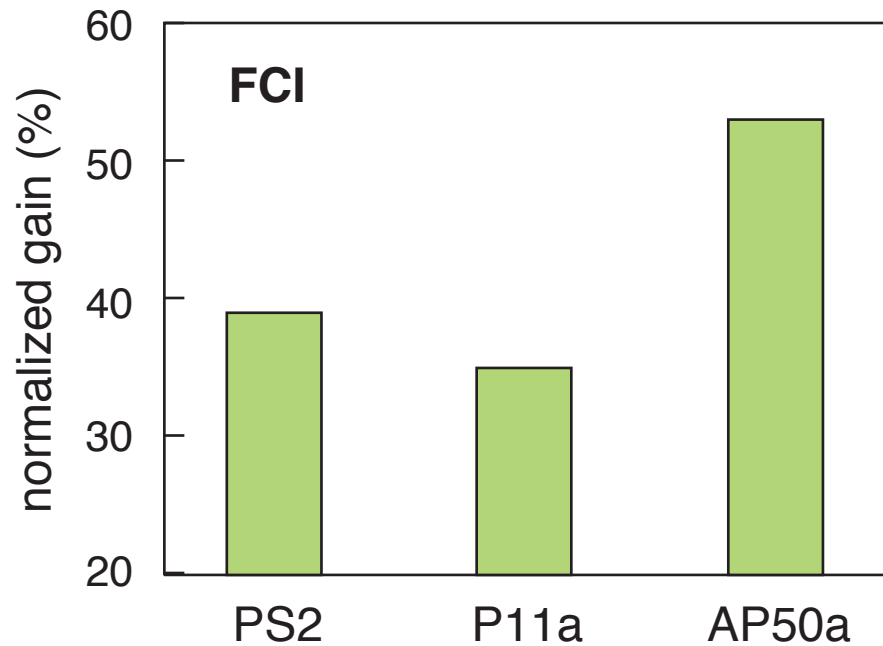

1 design

2 approach

3 results

Conceptual Mastery

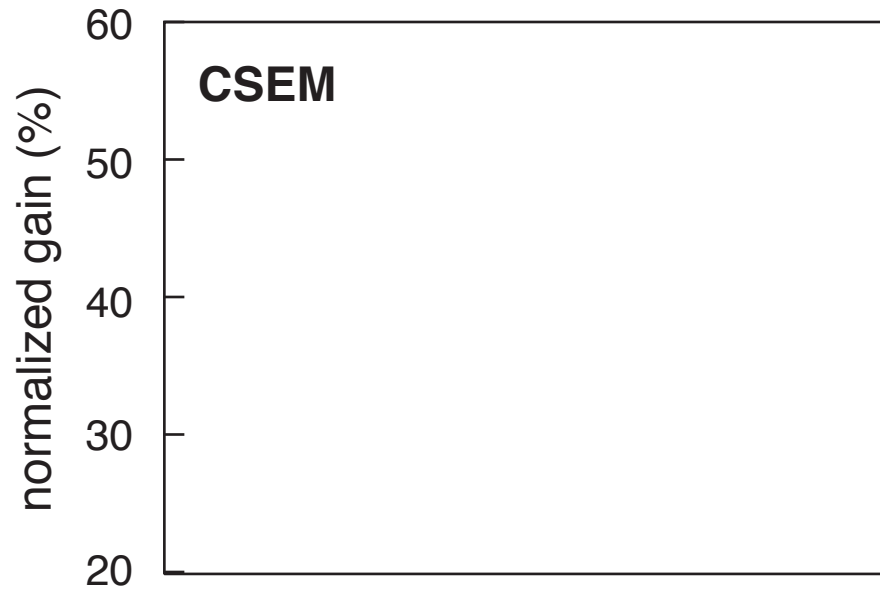

1 design

2 approach

3 results

Conceptual Mastery

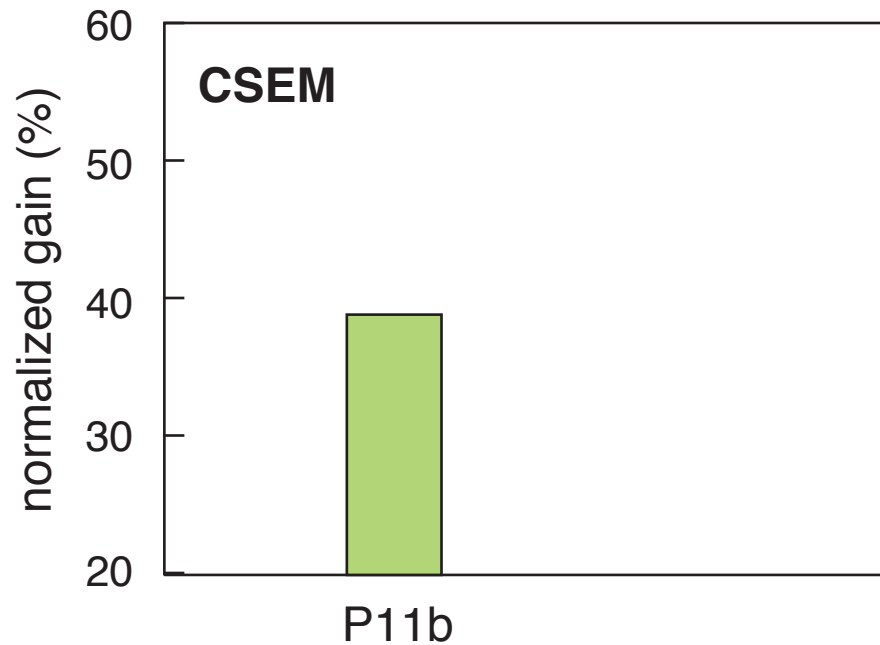

Conceptual Mastery

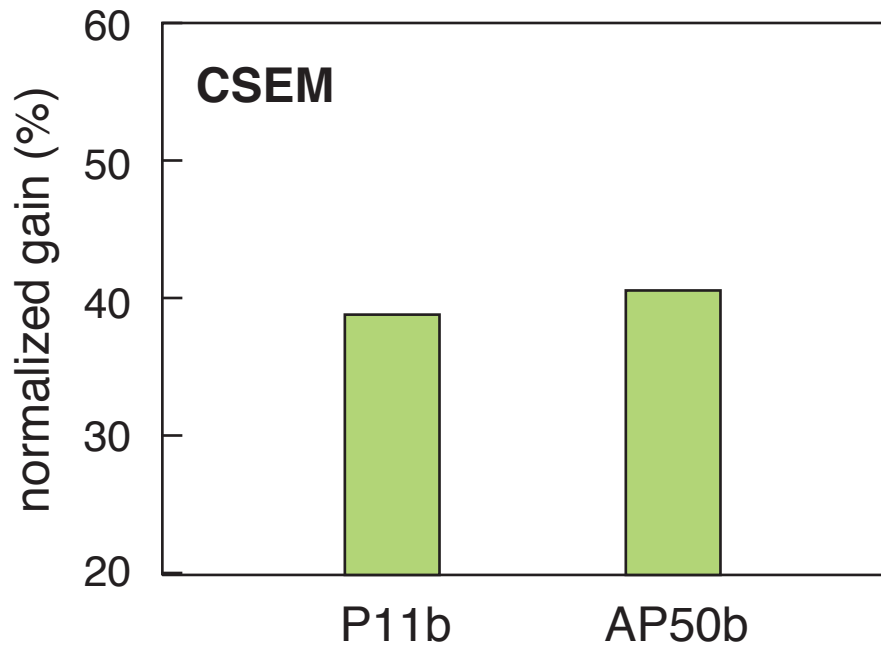



1 design

2 approach

3 results



Can create ownership of learning physics!

1 design

2 approach

3 results



Can create ownership of learning physics!

1 design

2 approach

3 results



“you come out with so much knowledge and experience and fun”

1 design

2 approach

3 results



Support

Cherry Murray

Course planning

Kelly Miller

Orad Reshef

Co-instructor

Carolann Koleci

Teaching staff

Kelly Miller

Orad Reshef

Michael Moebius

Sally Kang

Logistical support

Anas Challah

Peter Kjeer

Jordan Stephens

Wolfgang Rueckner

Nils Sorensen

Education Research

Marcelo Barros

Messias Borges-Silva

Brian Lukoff

Kelly Miller

Alvaro Neves

Julie Schell

Laura Tucker

Fauzy Wan

Junehee Yoo

1 design

2 approach

3 results



Support

Cherry Murray

Course planning

Kelly Miller

Orad Reshef

Co-instructor

Carolann Koleci

Teaching staff

Kelly Miller

Orad Reshef

Michael Moebius

Sally Kang

Logistical support

Anas Challah

Peter Kjeer

Jordan Stephens

Wolfgang Rueckner

Nils Sorensen

Education Research

Marcelo Barros

Messias Borges-Silva

Brian Lukoff

Kelly Miller

Alvaro Neves

Julie Schell

Laura Tucker

Fauzy Wan

Junehee Yoo

and the students pioneers in AP50!

1 design

2 approach

3 results

A photograph of four students in a laboratory setting. A woman with glasses is using a pipette to transfer liquid into a white cup. Another woman is smiling and looking at the experiment. A man in a plaid shirt is standing nearby, also smiling. A woman in a maroon hoodie is looking at the equipment. The equipment includes a wooden box with a circuit board and various components inside.

for a copy of this presentation:
mazur.harvard.edu

Follow me!



[eric_mazur](https://twitter.com/eric_mazur)

1 design

2 approach

3 results