

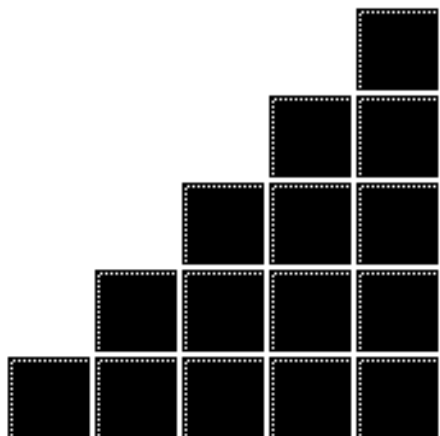

UNDERSTANDING OR MEMORIZATION: ARE WE TEACHING THE RIGHT THING?

Eric Mazur
Harvard University

Physics Colloquium
University of British Columbia
11 February 1999



① Problem

② Cause

③ Remedy

PROBLEM? WHAT PROBLEM?

Traditional science education ineffective...

- lack of understanding
- frustration
- lack of basic knowledge



LACK OF UNDERSTANDING



LACK OF UNDERSTANDING

Well, "hot" is a relative term...

You see, given temperatures rise, regardless of mass.

Yeah, Galileo observed rising temperatures will decrease with the exposure of an endothermic source.

Endothermic?

True transparence will persist until this one irresistible calorie interacts, thus altering the system.



FRUSTRATION



FRUSTRATION

“I took four years of science and four years of math...

A waste of my time,
a waste of the teacher's time,
and a waste of space...

You know,
I took *physics*.
For *what?*”

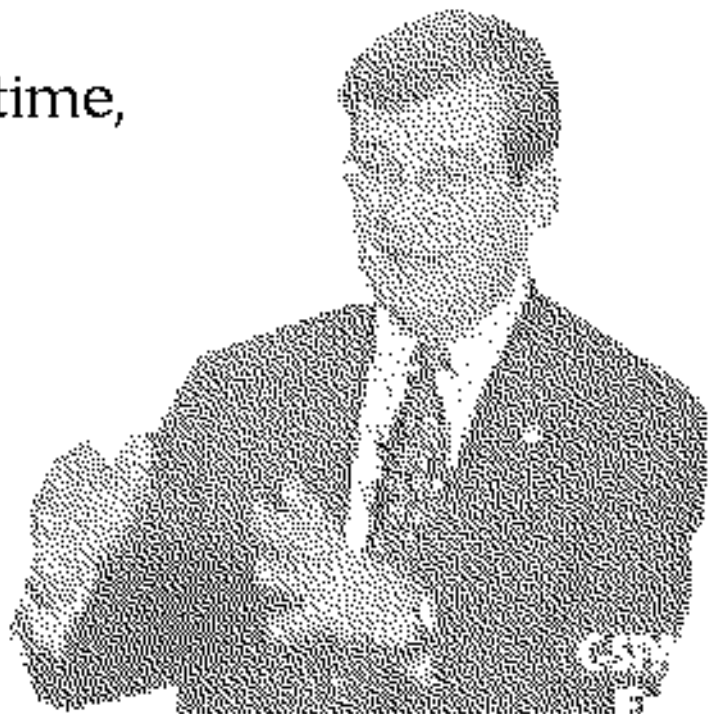

FRUSTRATION



LACK OF BASIC KNOWLEDGE



① Problem

② Cause

③ Remedy

THE CAUSE

1. Lectures focus on transfer of information...

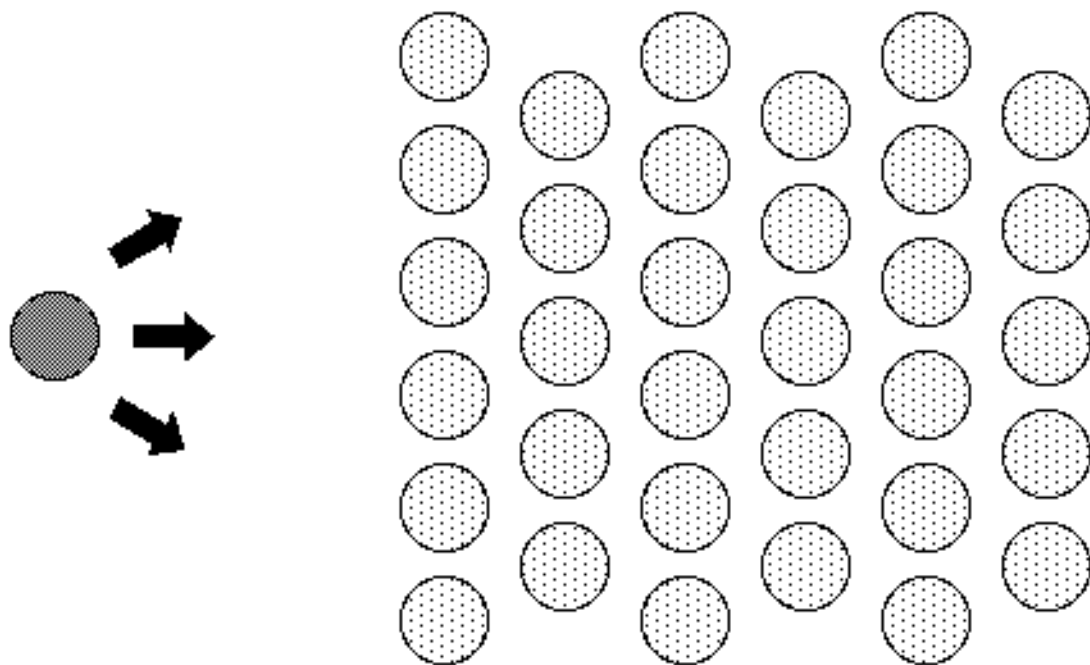

THE CAUSE

... but the information doesn't sink in!

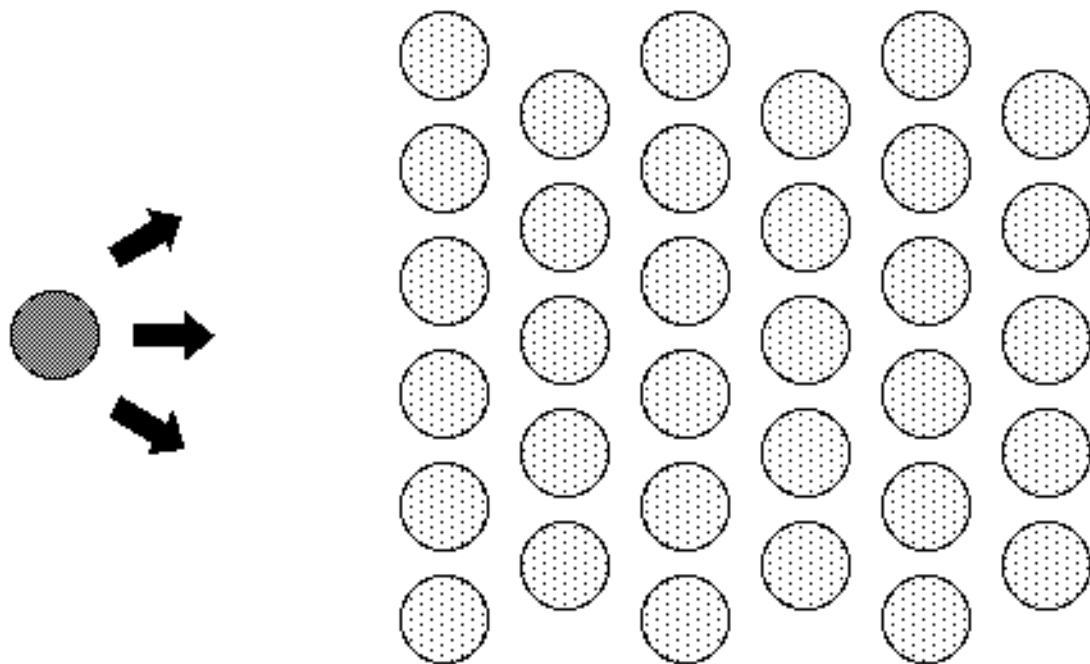

THE CAUSE

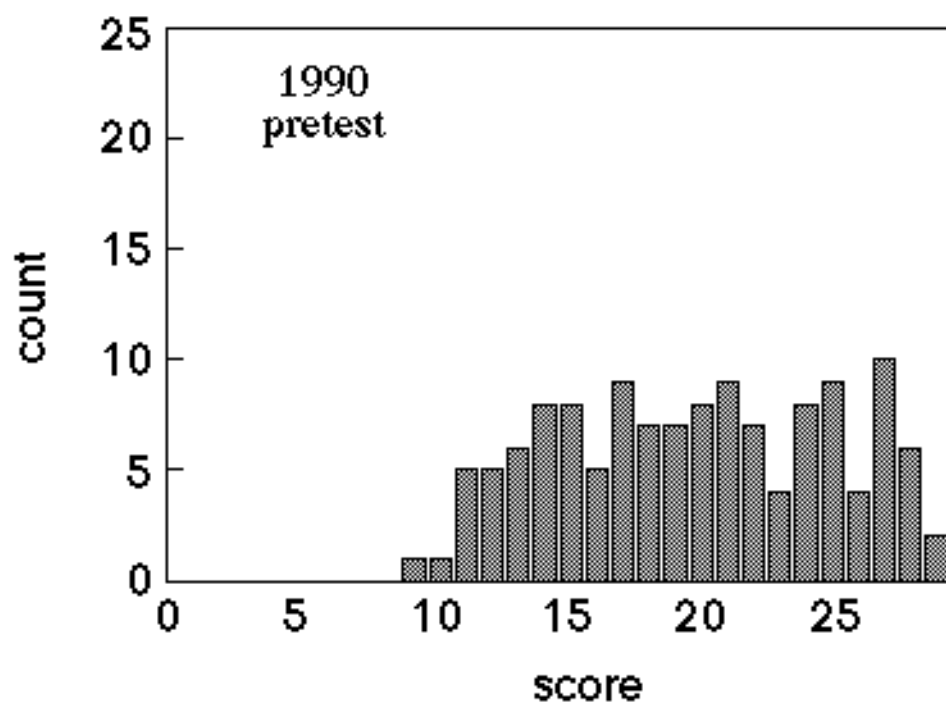

THE CAUSE

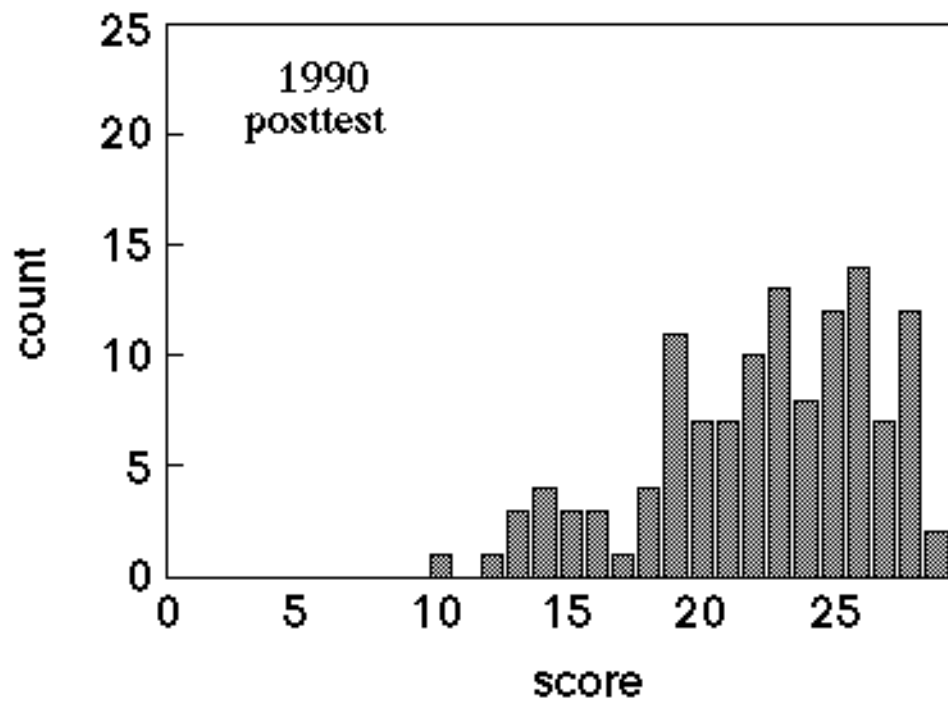

THE CAUSE

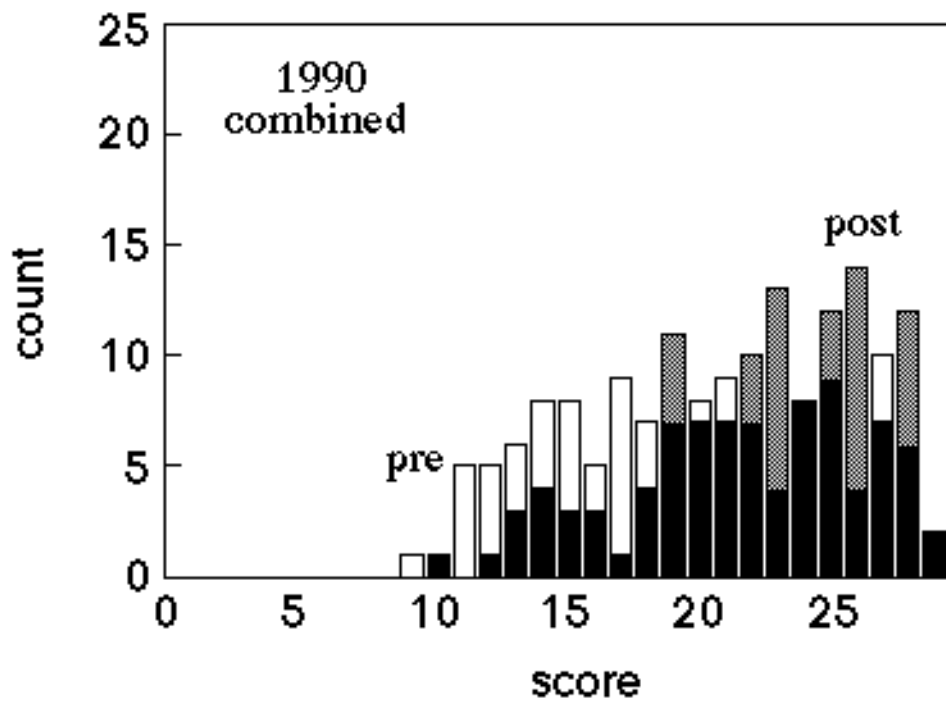

THE CAUSE

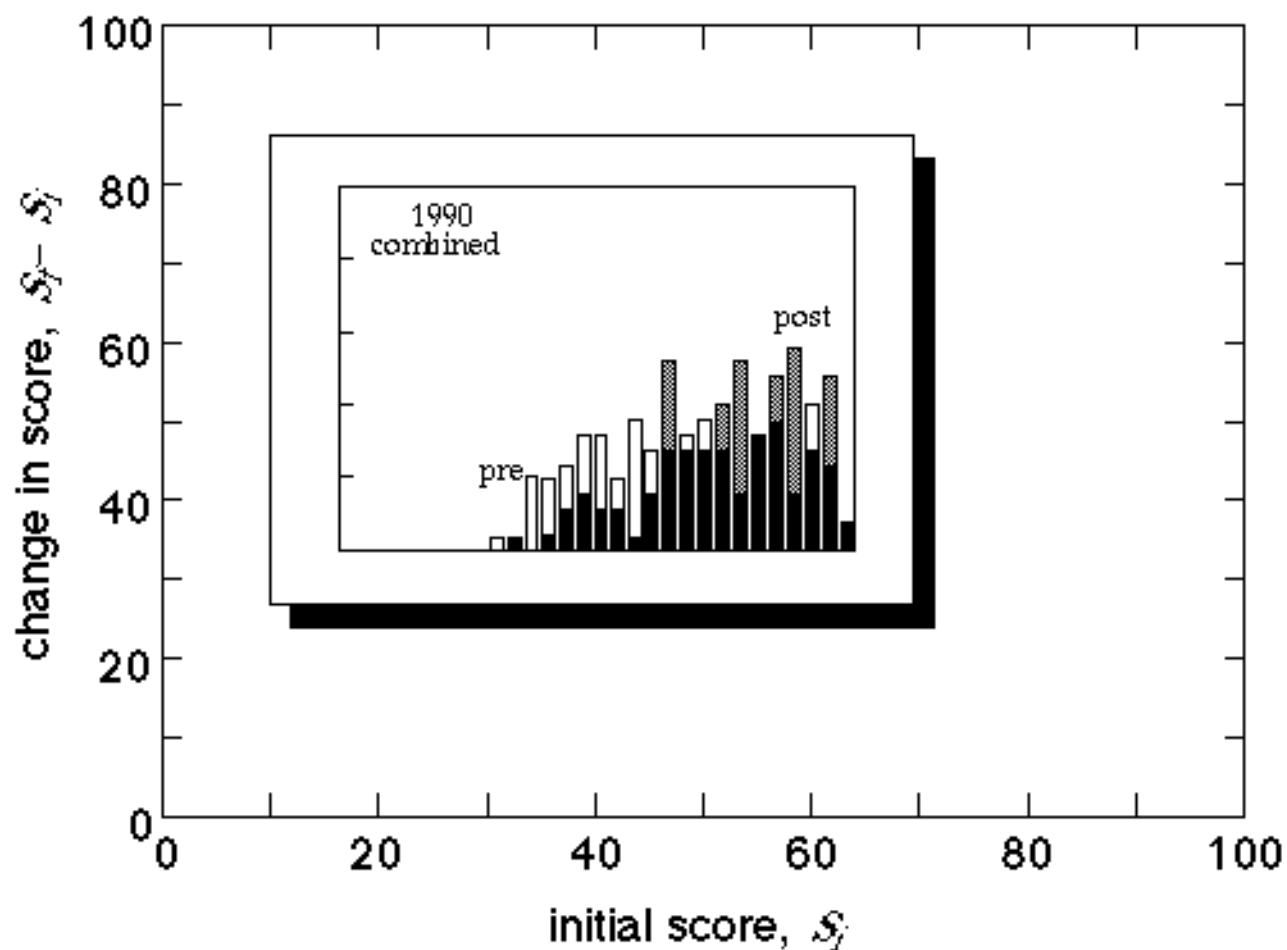

THE CAUSE

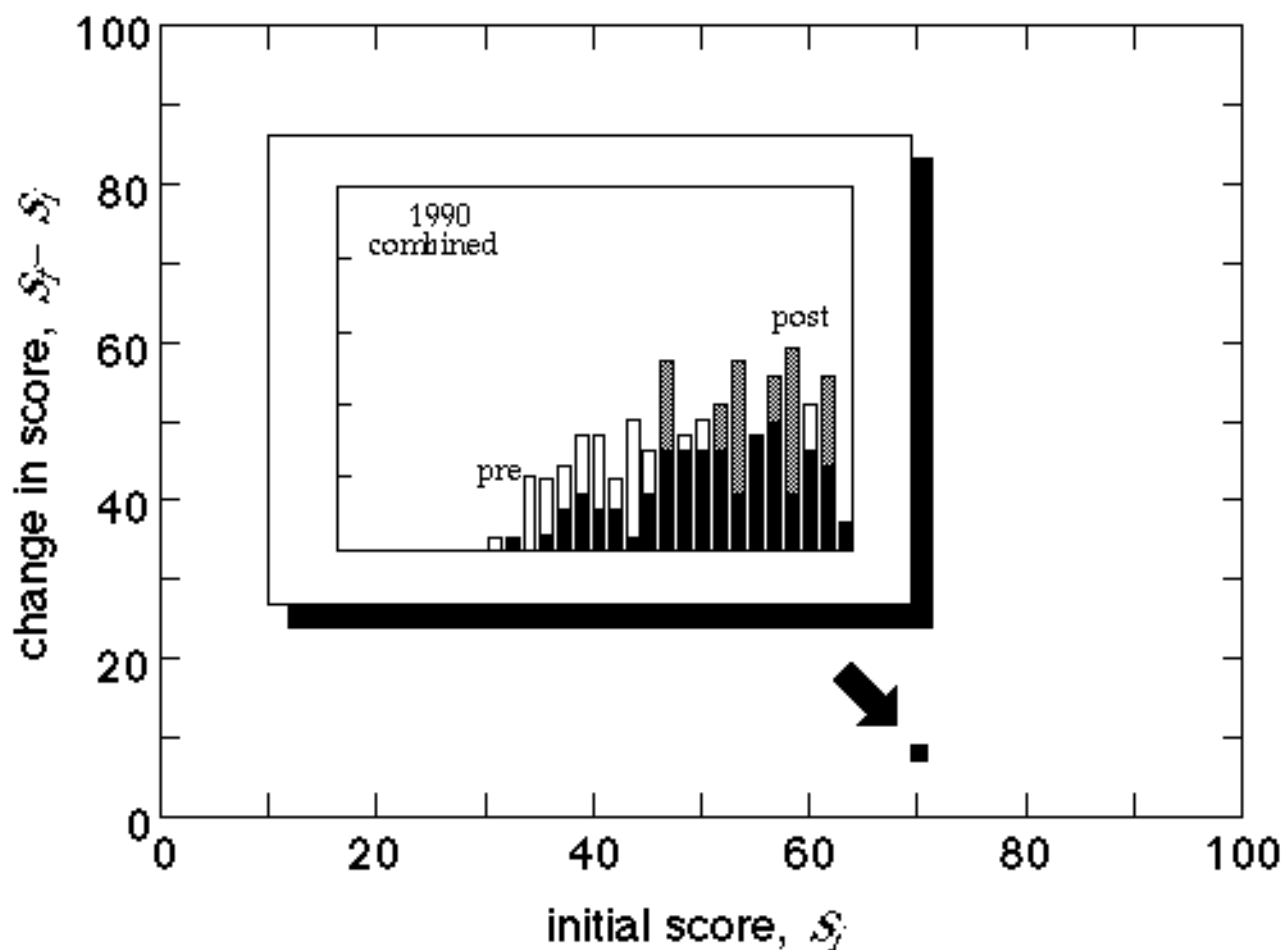

THE CAUSE

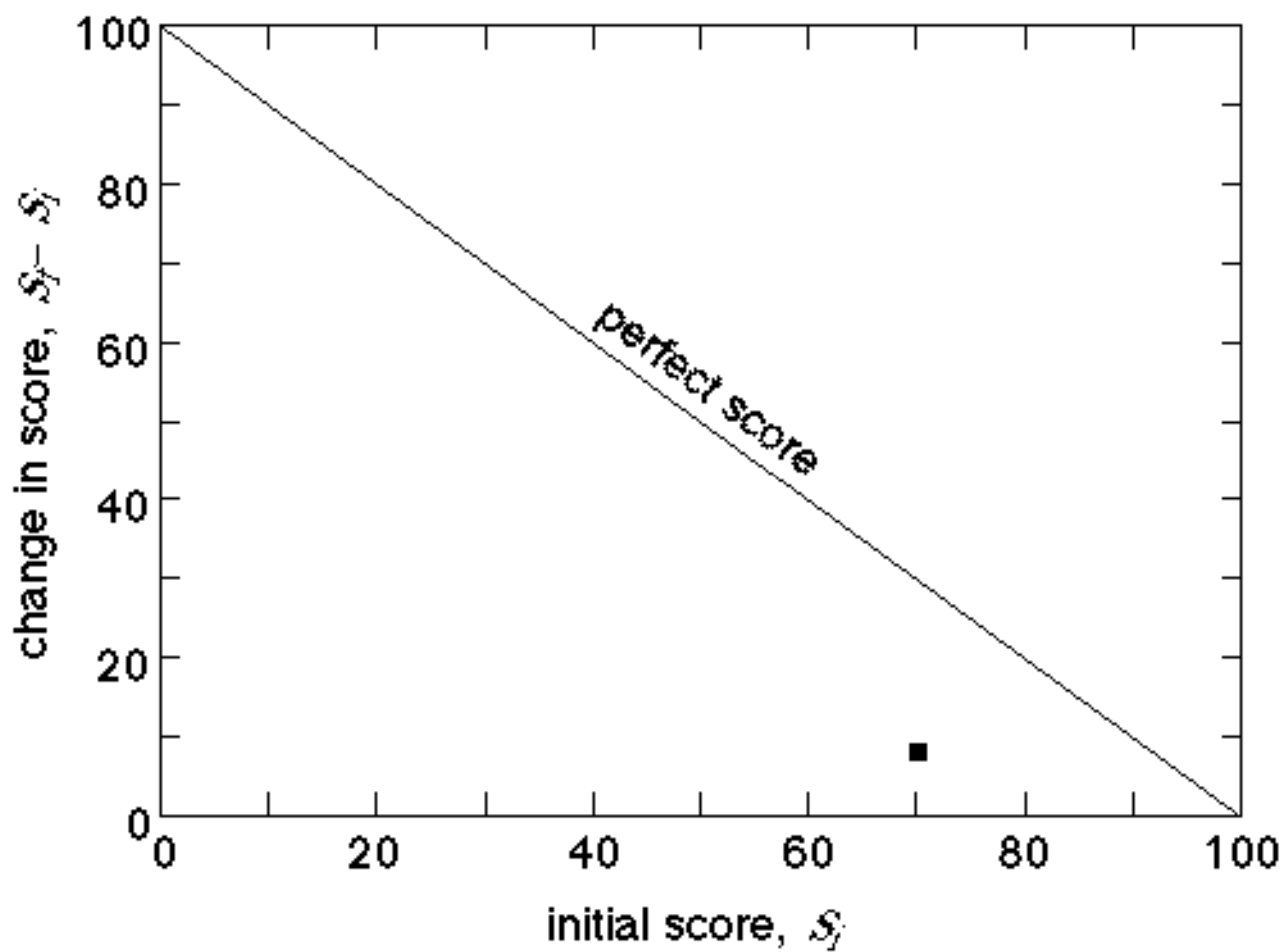

THE CAUSE

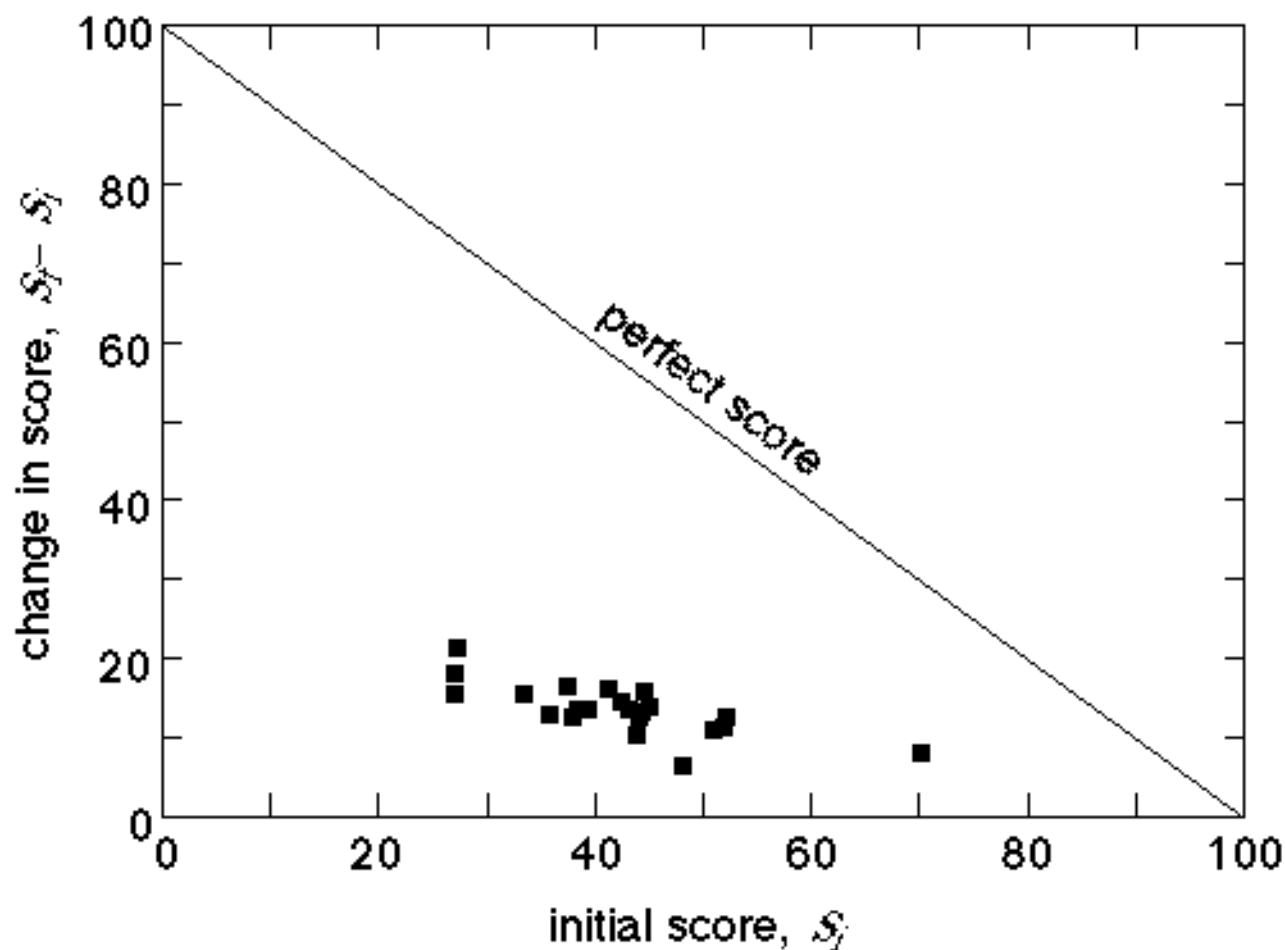

THE CAUSE

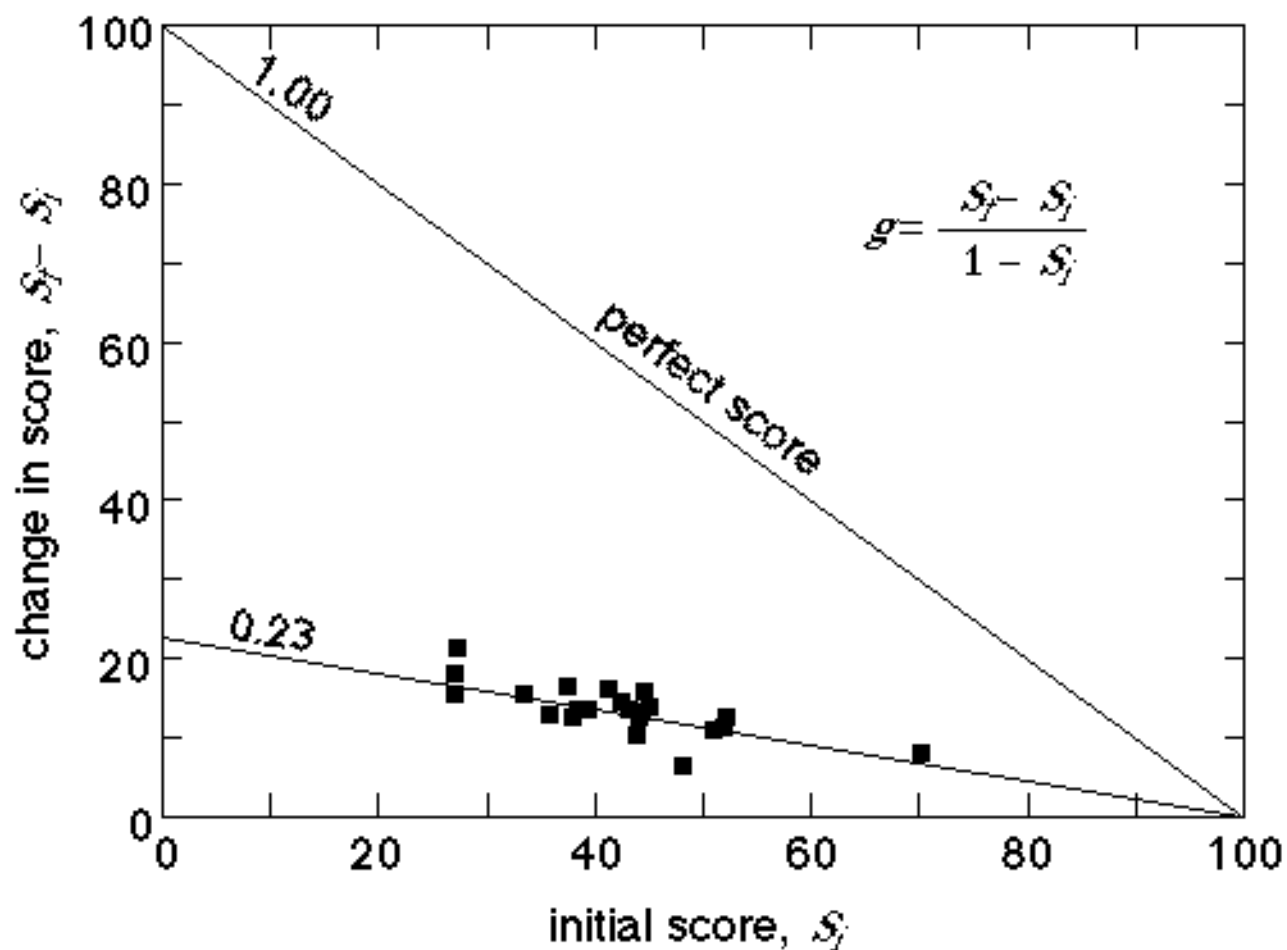

THE CAUSE

2. Conventional problems reinforce bad study habits

Calculate:

- (a) the current in the $2\text{-}\Omega$ resistor, and
- (b) the potential difference between points a and b .

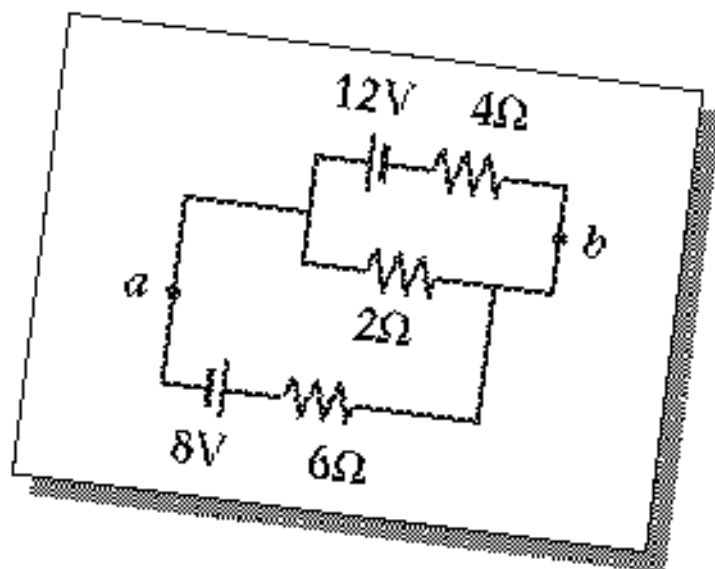

THE CAUSE

Are basic principles understood?

When S is closed, what happens to the:

- (a) intensities of A and B ?
- (b) intensity of C ?
- (c) current through battery?
- (d) voltage drop across A , B , and C ?
- (e) total power dissipated?

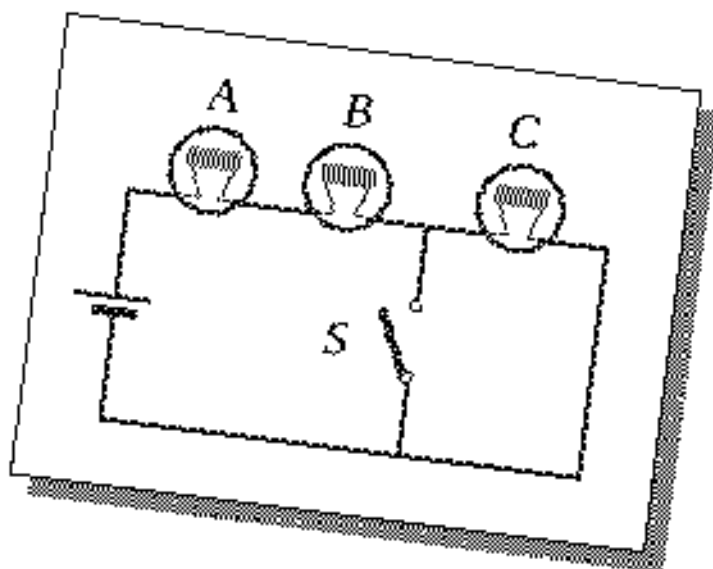

THE CAUSE

conventional

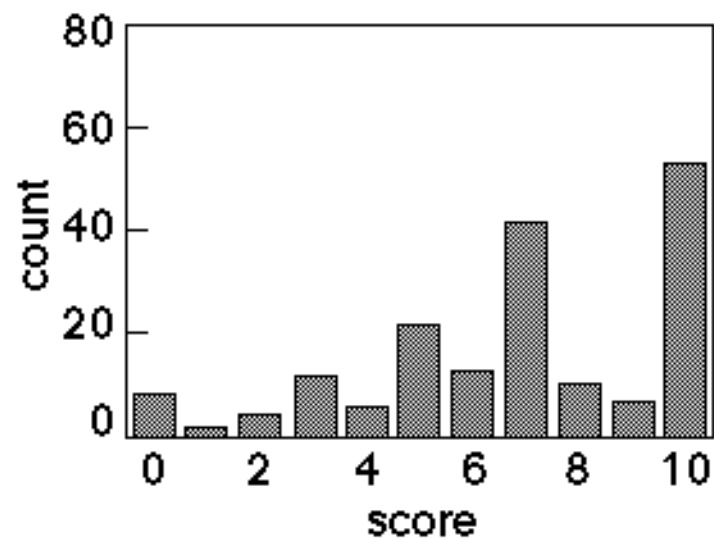

conceptual

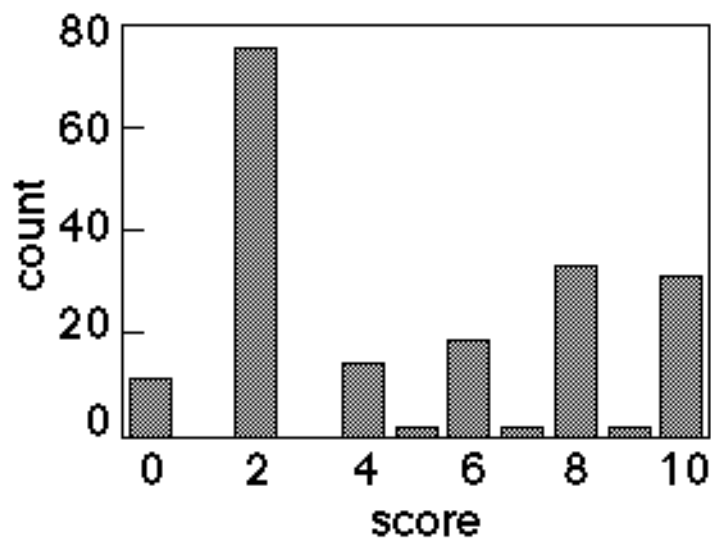

THE CAUSE

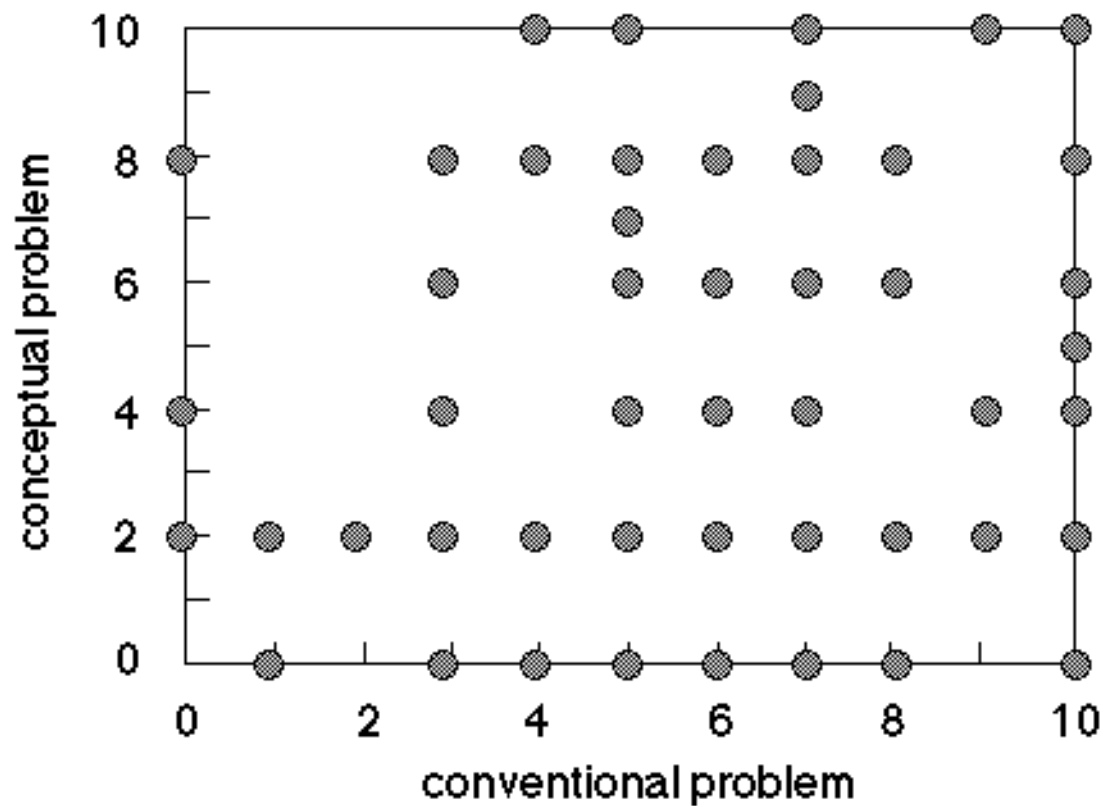

THE CAUSE

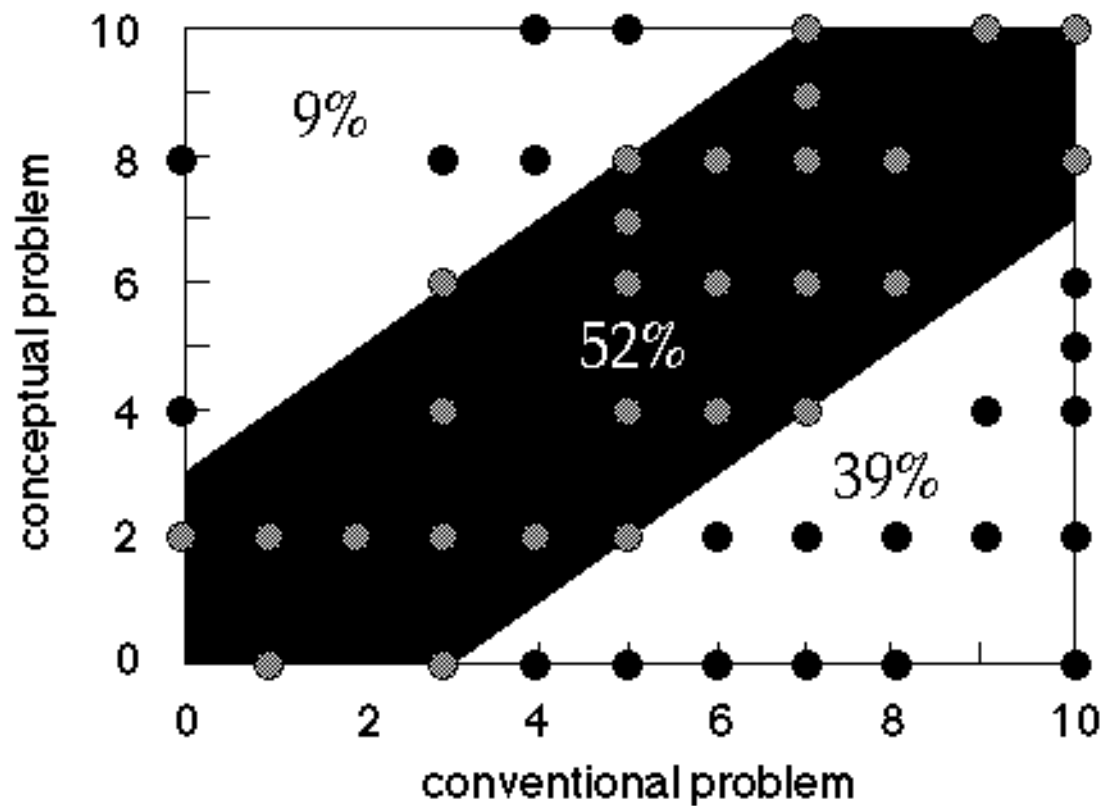

① Problem

② Cause

③ Remedy

PEER INSTRUCTION

Give students more responsibility for learning!



PEER INSTRUCTION

1. Recognize the inefficacy of the lecture method!

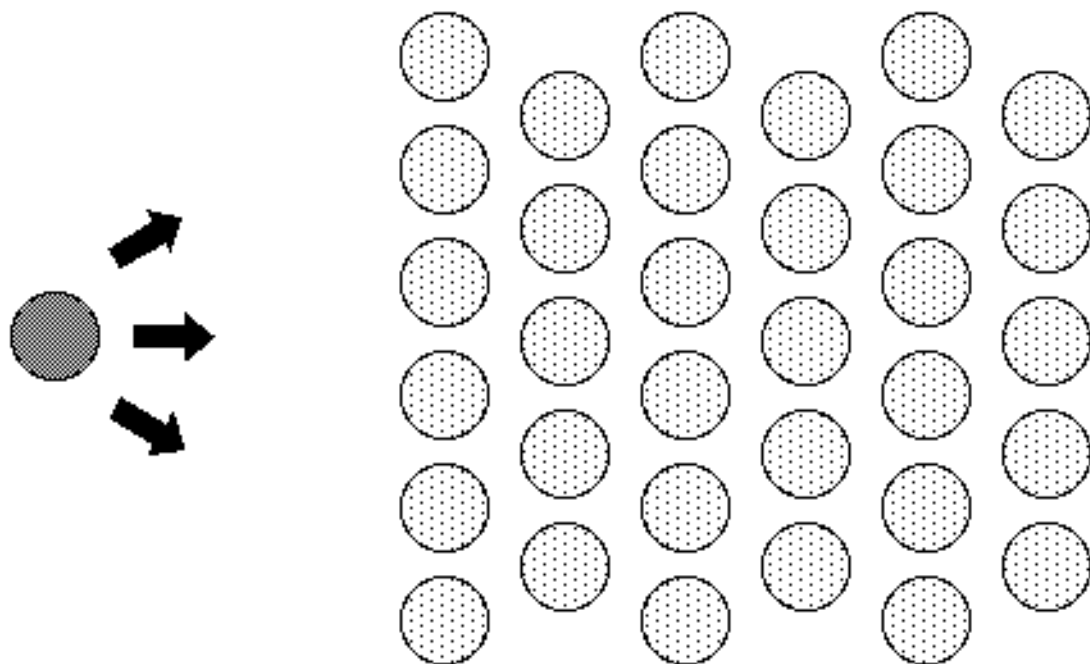

PEER INSTRUCTION

1. Recognize the inefficacy of the lecture method!

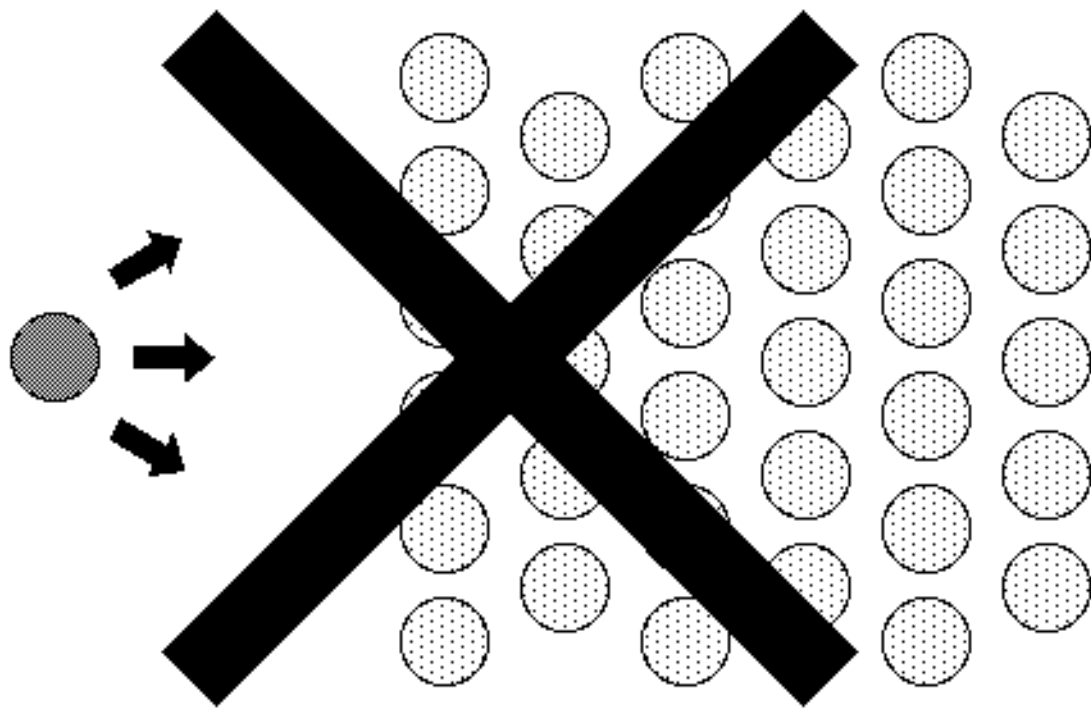

PEER INSTRUCTION

2. Move first exposure to material **out of classroom**

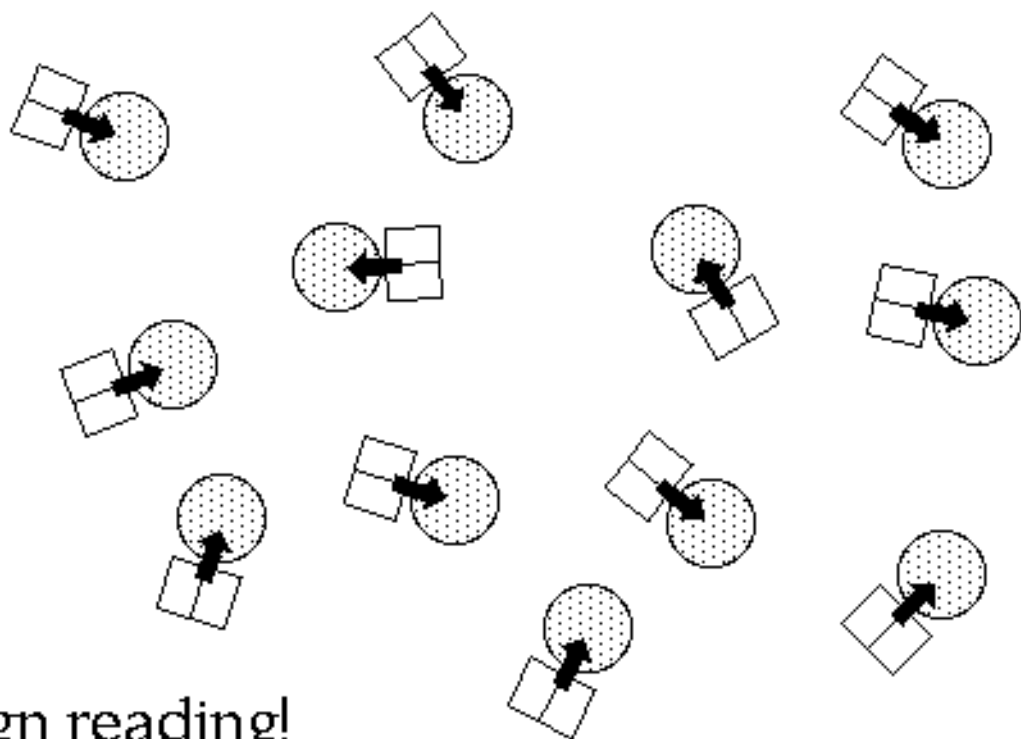

...assign reading!



PEER INSTRUCTION

3. Use class to deepen and broaden understanding



PEER INSTRUCTION

... by transferring some **additional** information ...

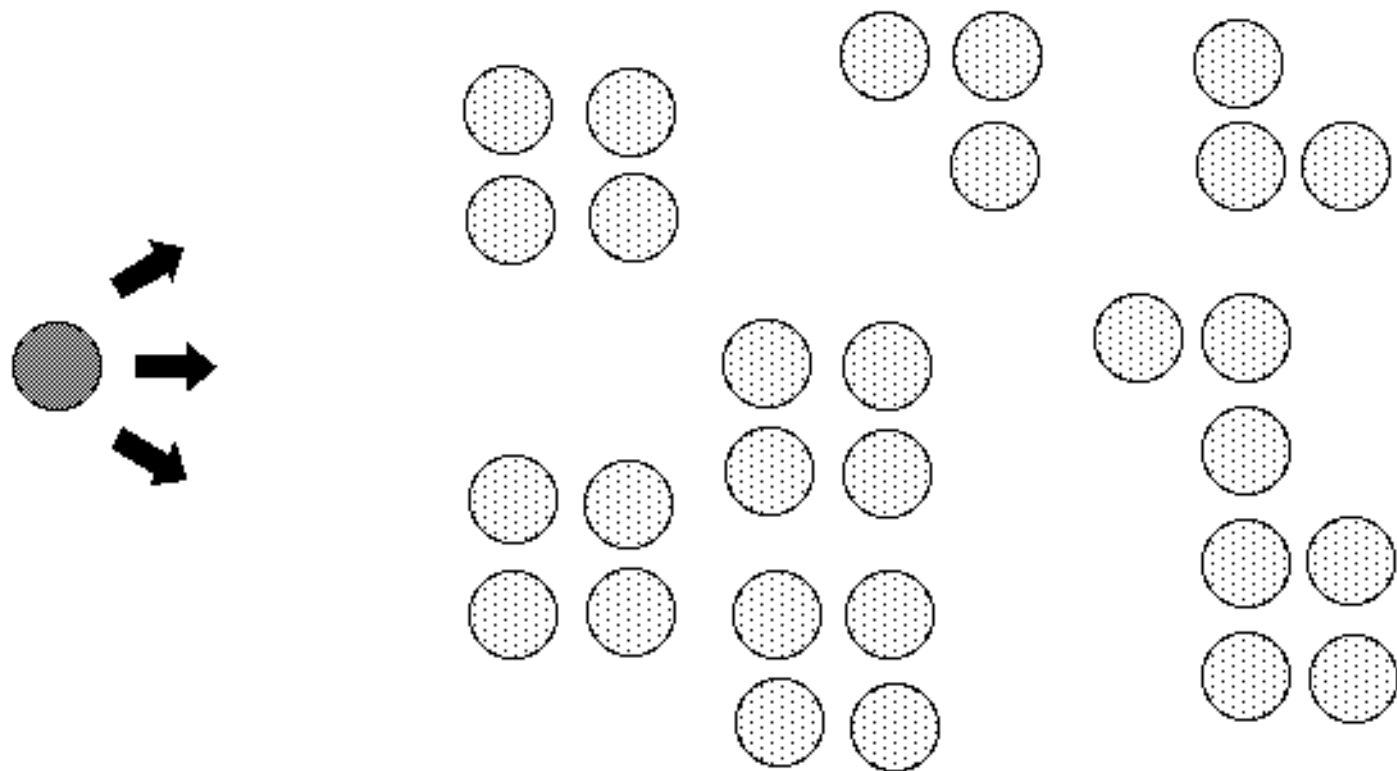

PEER INSTRUCTION

... and by giving students opportunities to **think**.

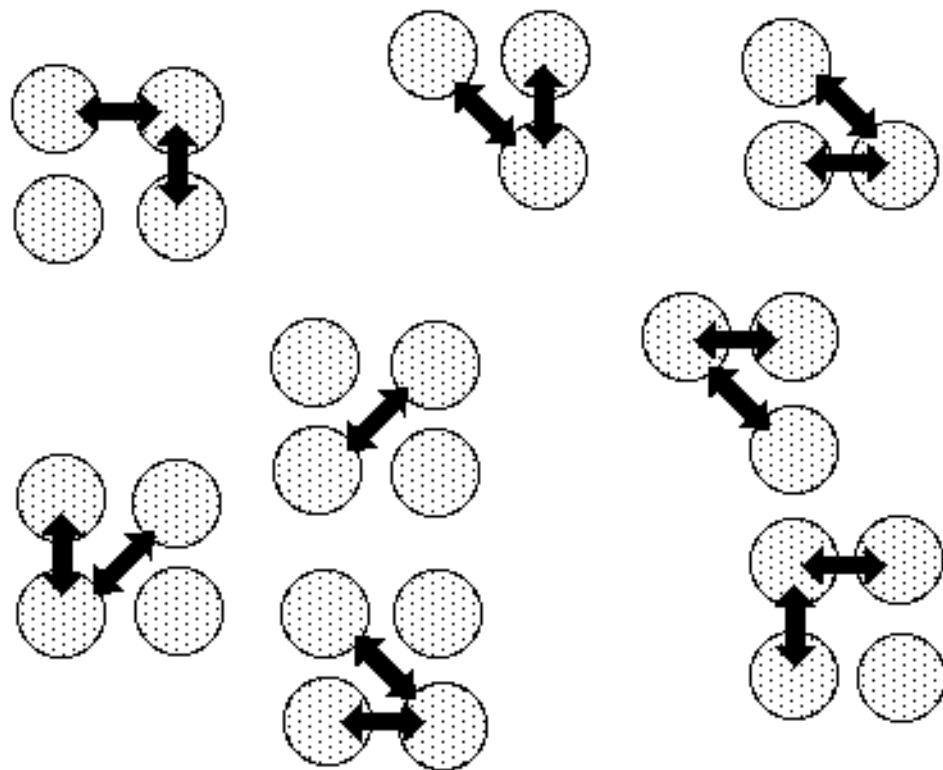

PEER INSTRUCTION

Better yet: **Learn from your students ...**

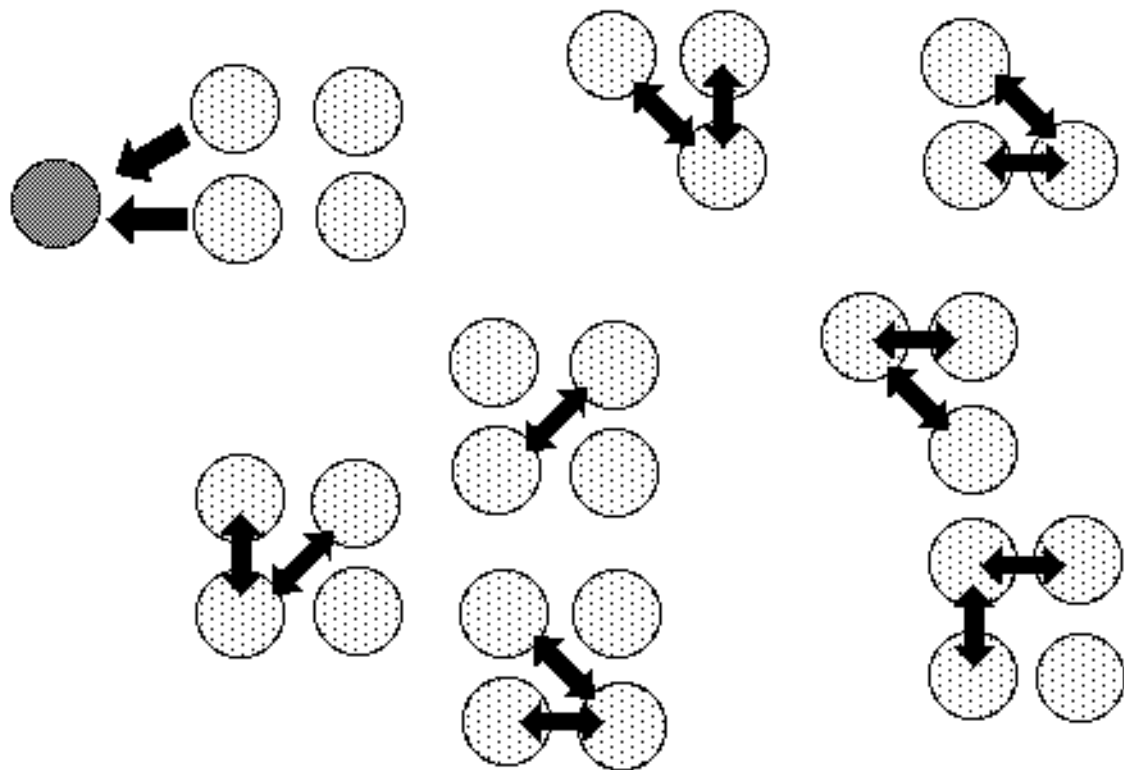

PEER INSTRUCTION

Better yet: **Learn from your students ...**

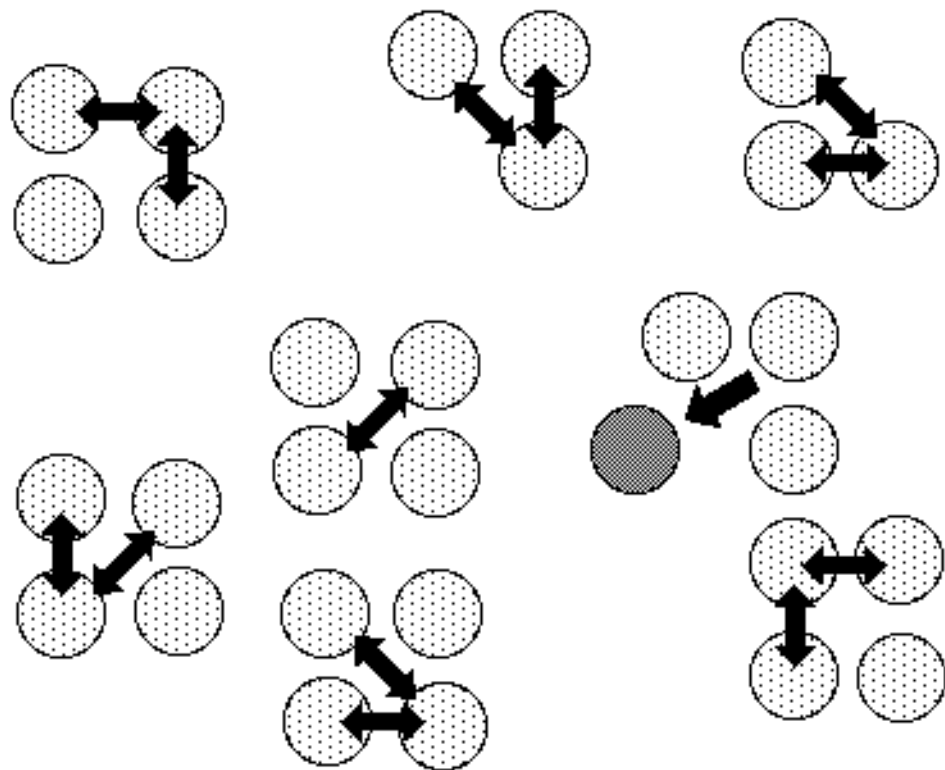

PEER INSTRUCTION

Better yet: **Learn from your students ...**

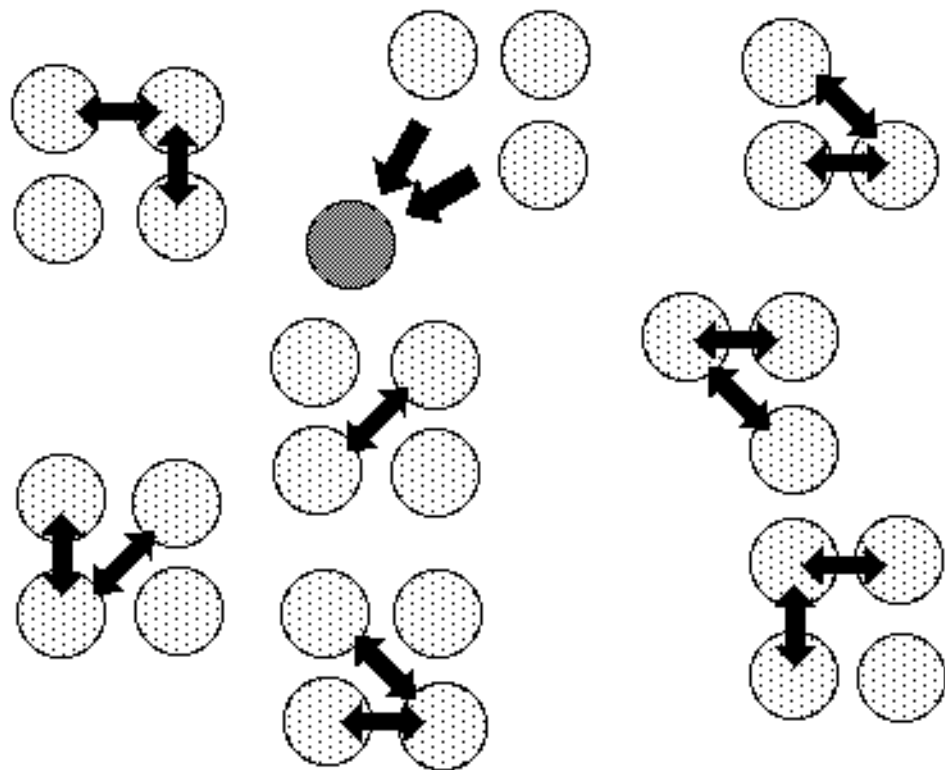

PEER INSTRUCTION

... bring in your **Teaching Assistants** too...!

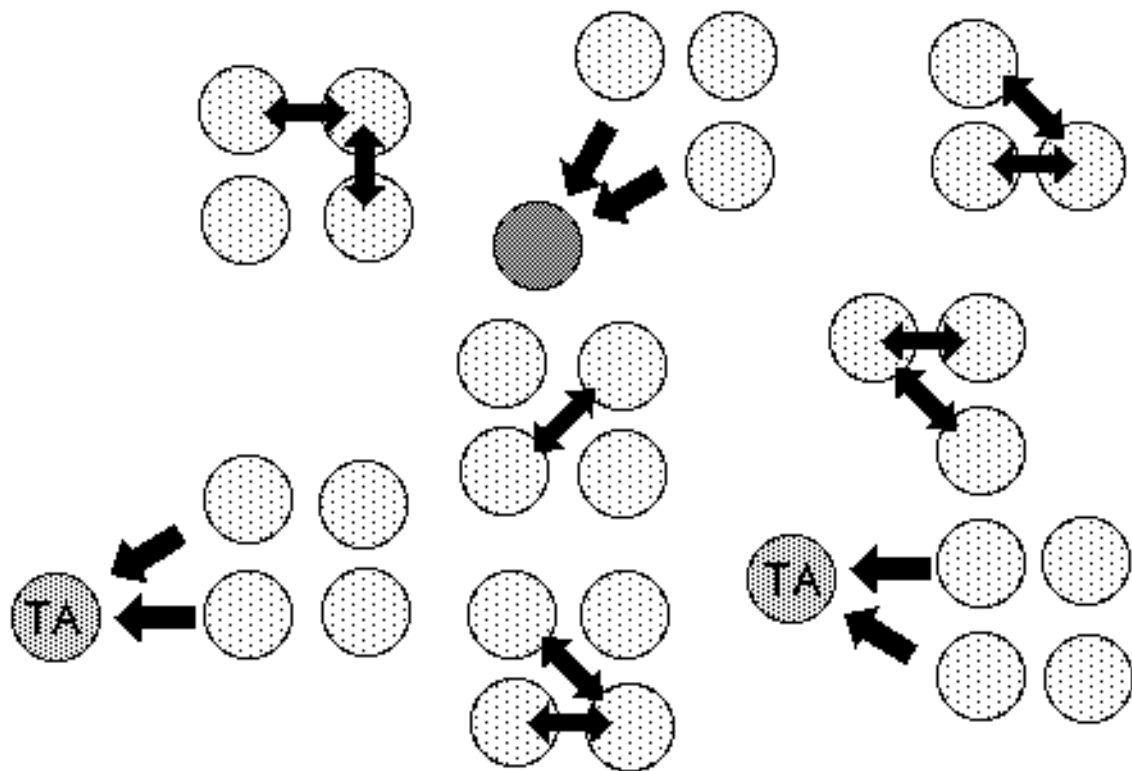

Main features:

- Pre-class reading
- In class: depth, not coverage
- ConcepTests



CONCEPTEST

1. Question
2. Thinking
3. Individual answer
4. Peer discussion
5. Group answer
6. Explanation



CONCEPTEST

1. Question
2. Thinking
3. Individual answer
4. Peer discussion
5. Group answer
6. Explanation

CONCEPTEST



CONCEPTTEST

Individual answers

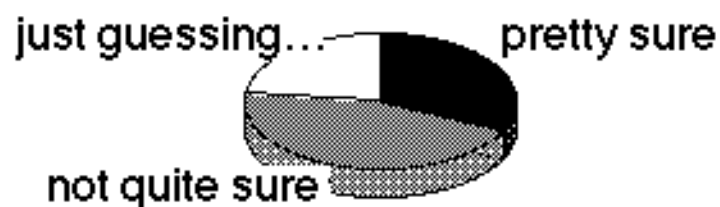
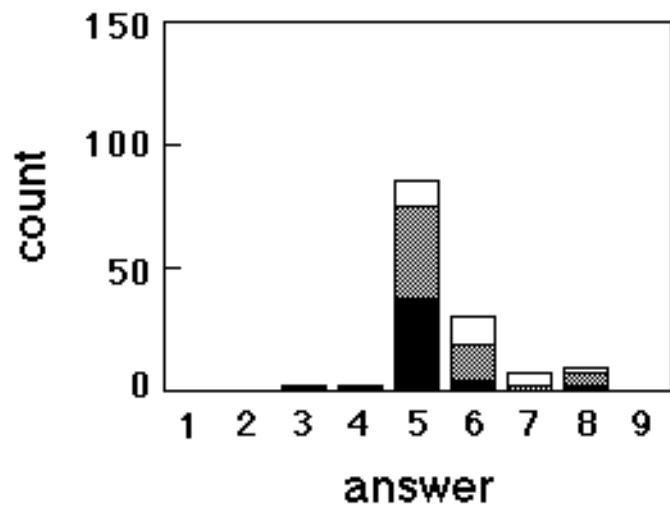

CONCEPTTEST

Group answers

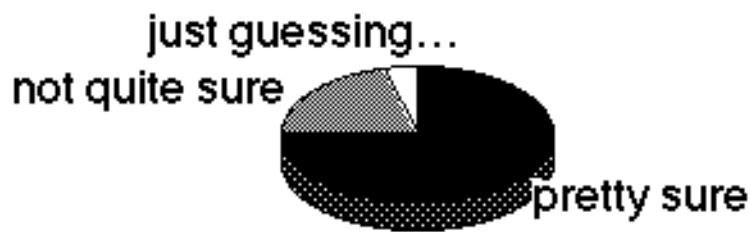
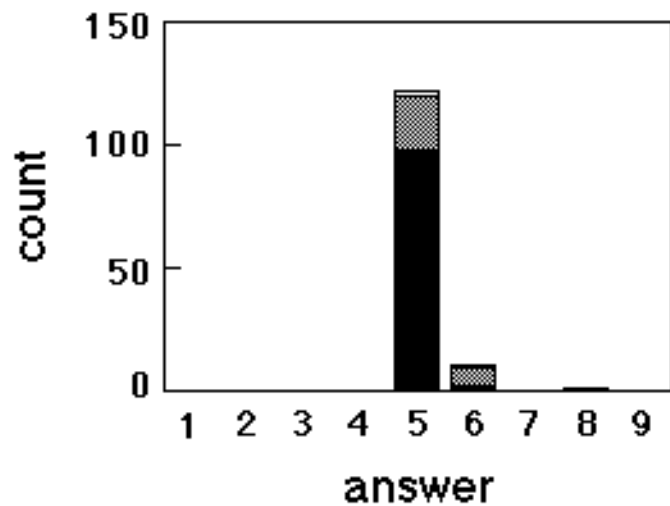

CONCEPTTEST

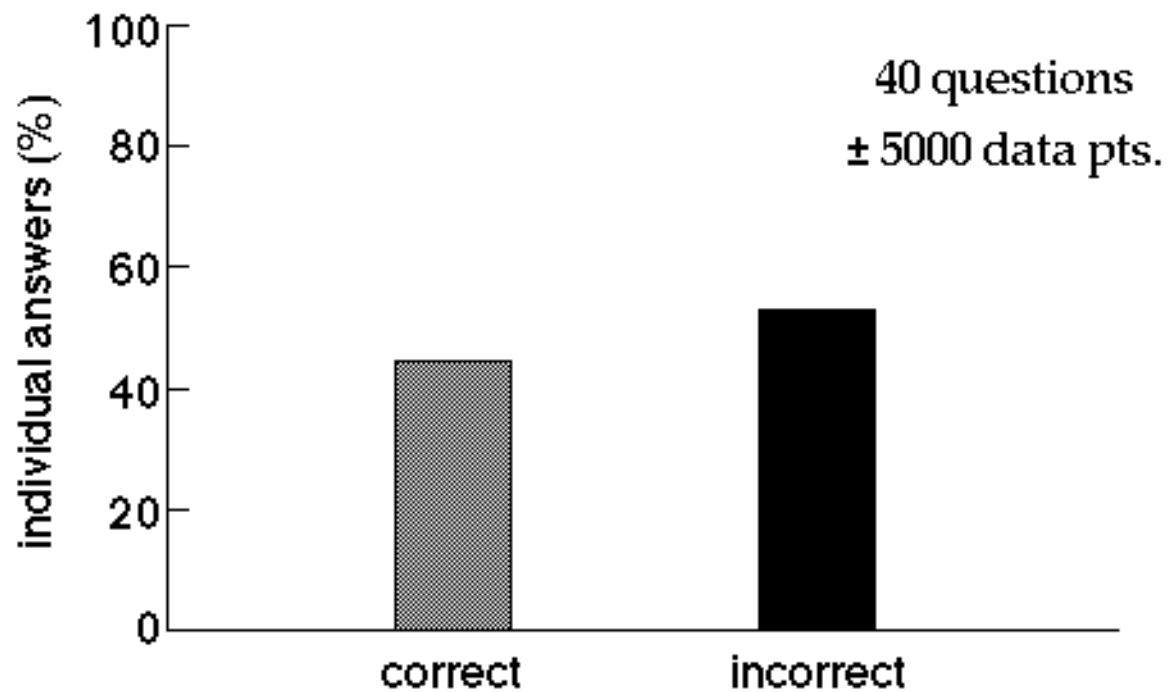

CONCEPTTEST

Students converge on correct answer!

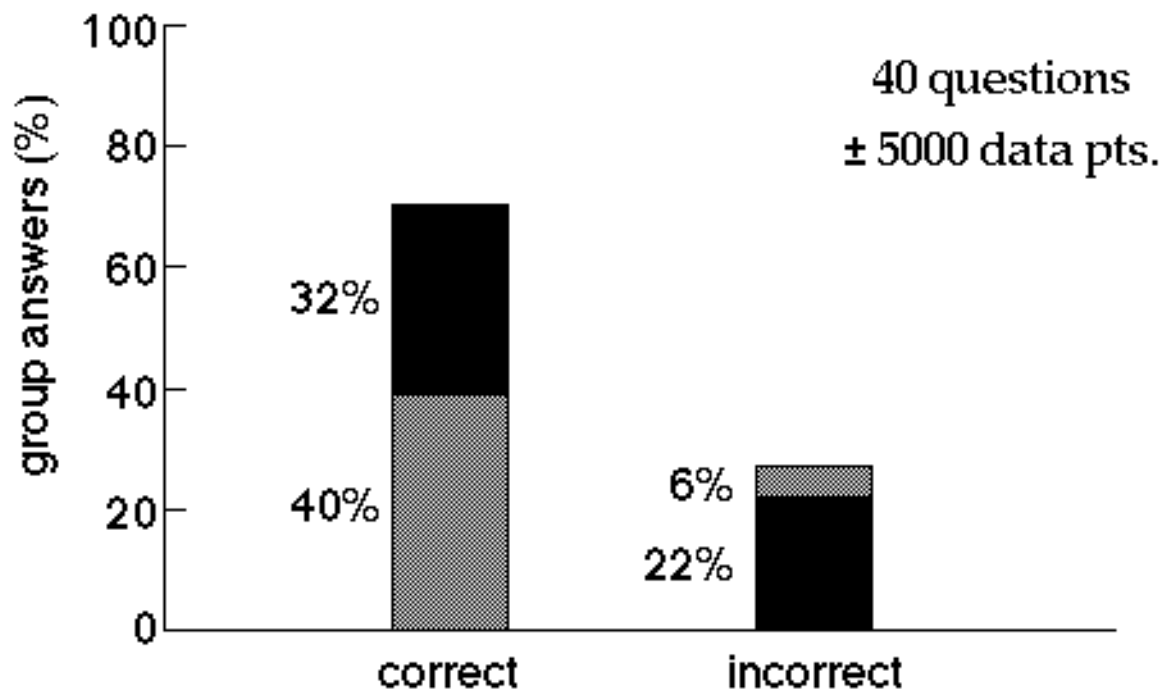

CONCEPTEST

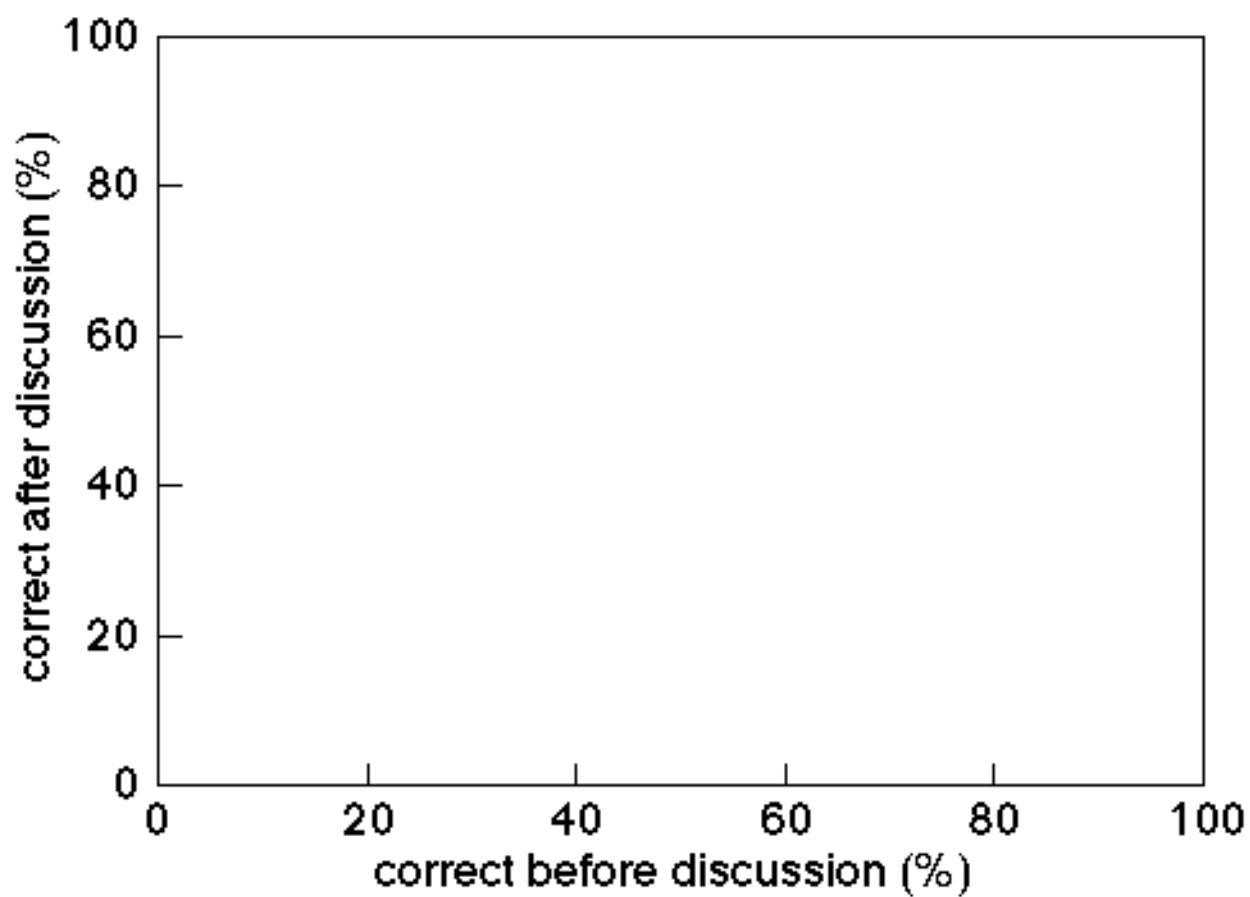

CONCEPTEST

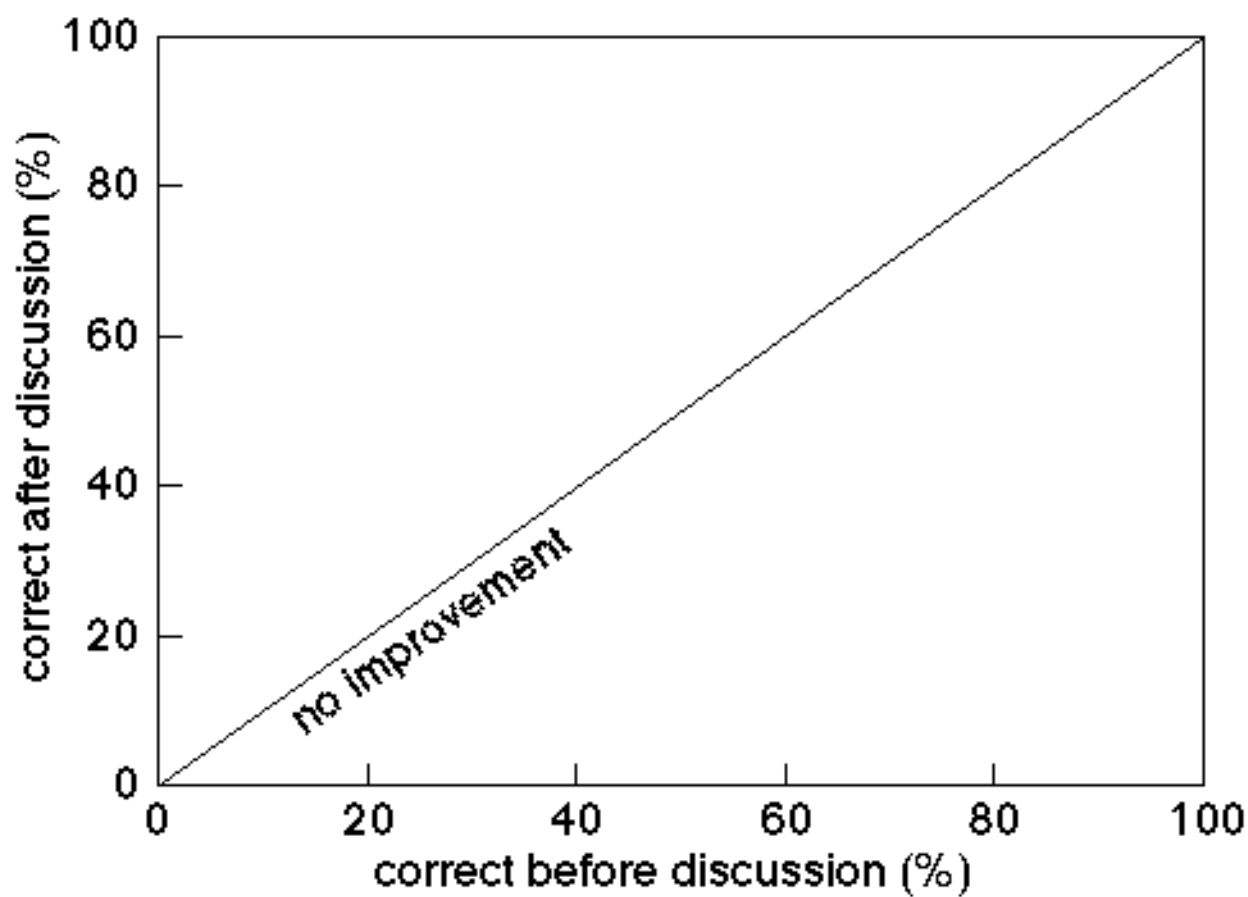

CONCEPTTEST

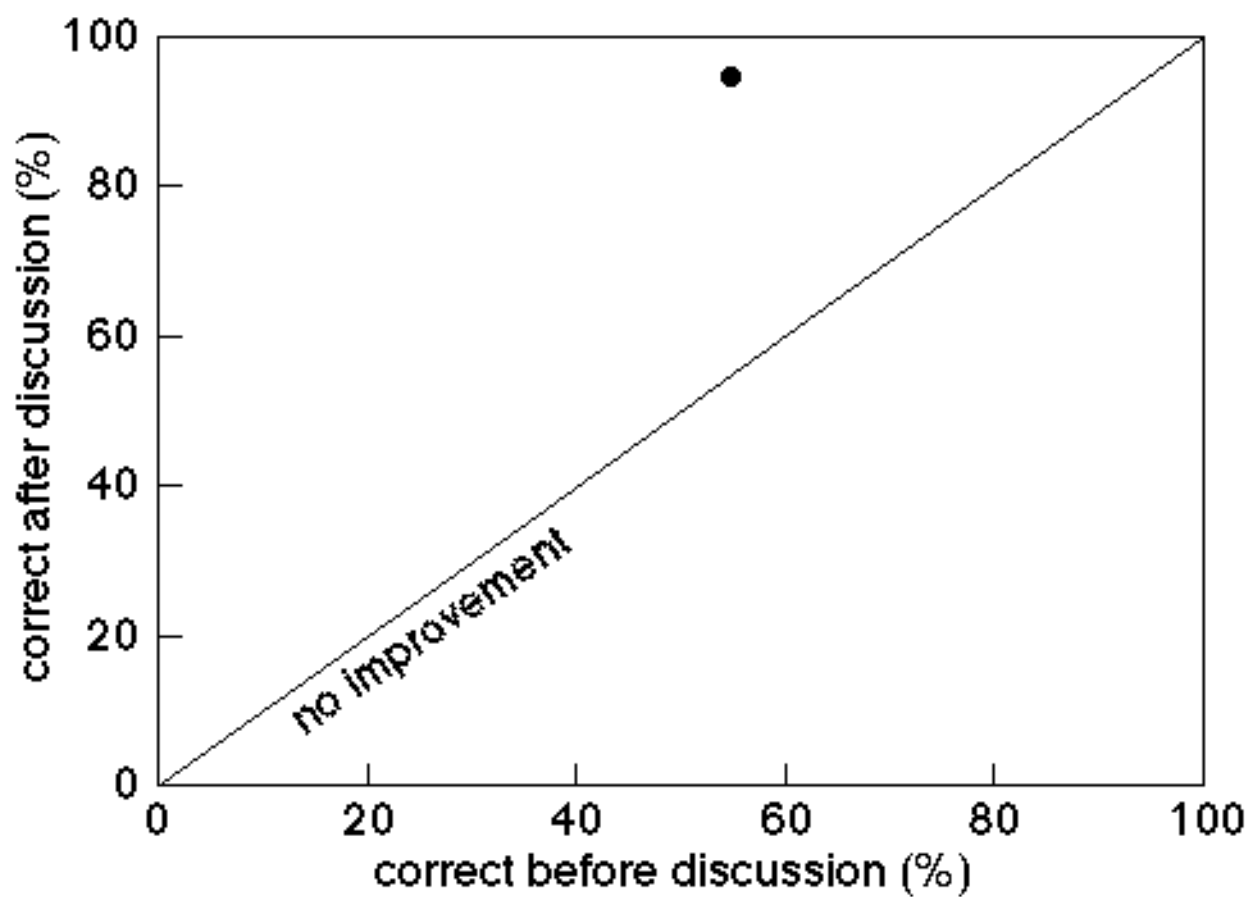

CONCEPTTEST

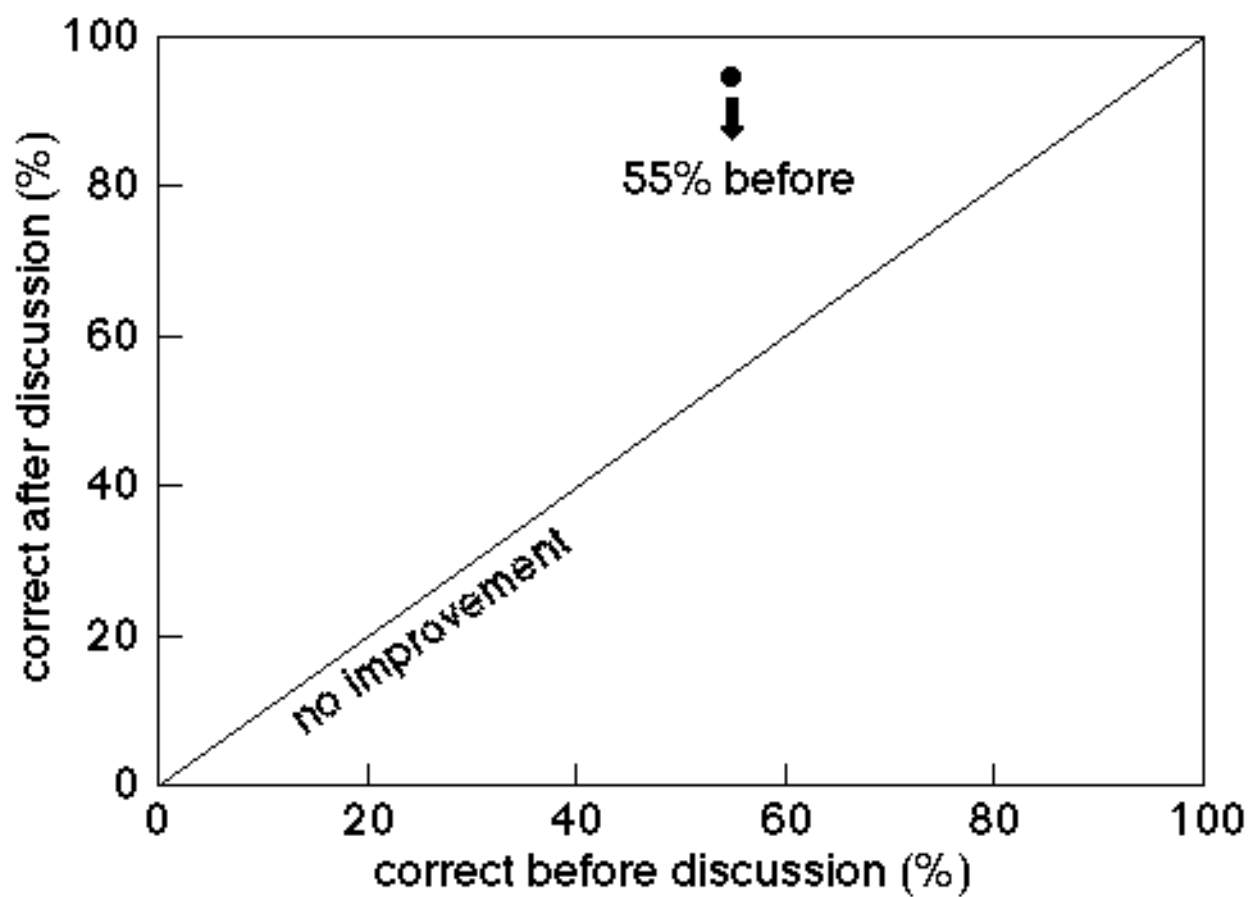

CONCEPTTEST

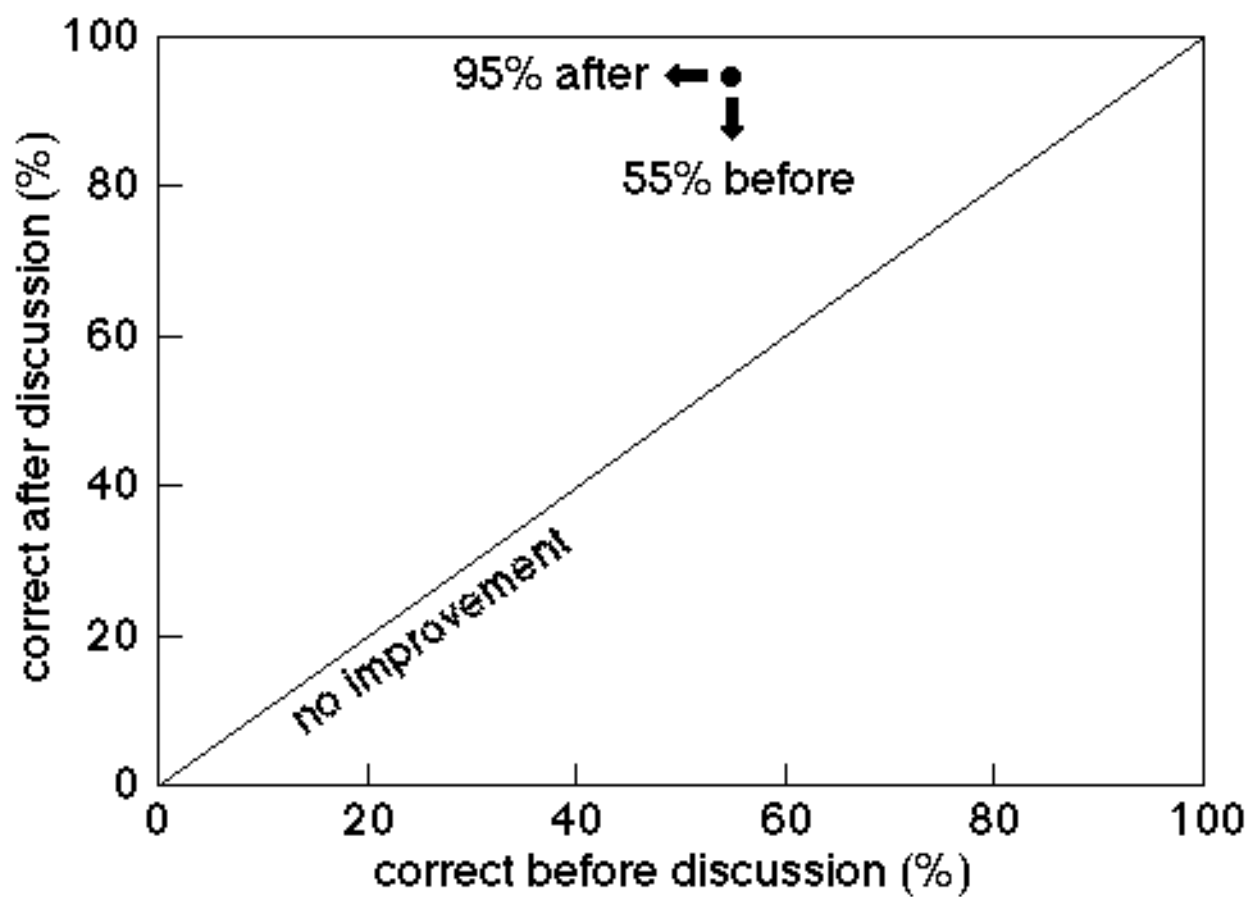

CONCEPTTEST

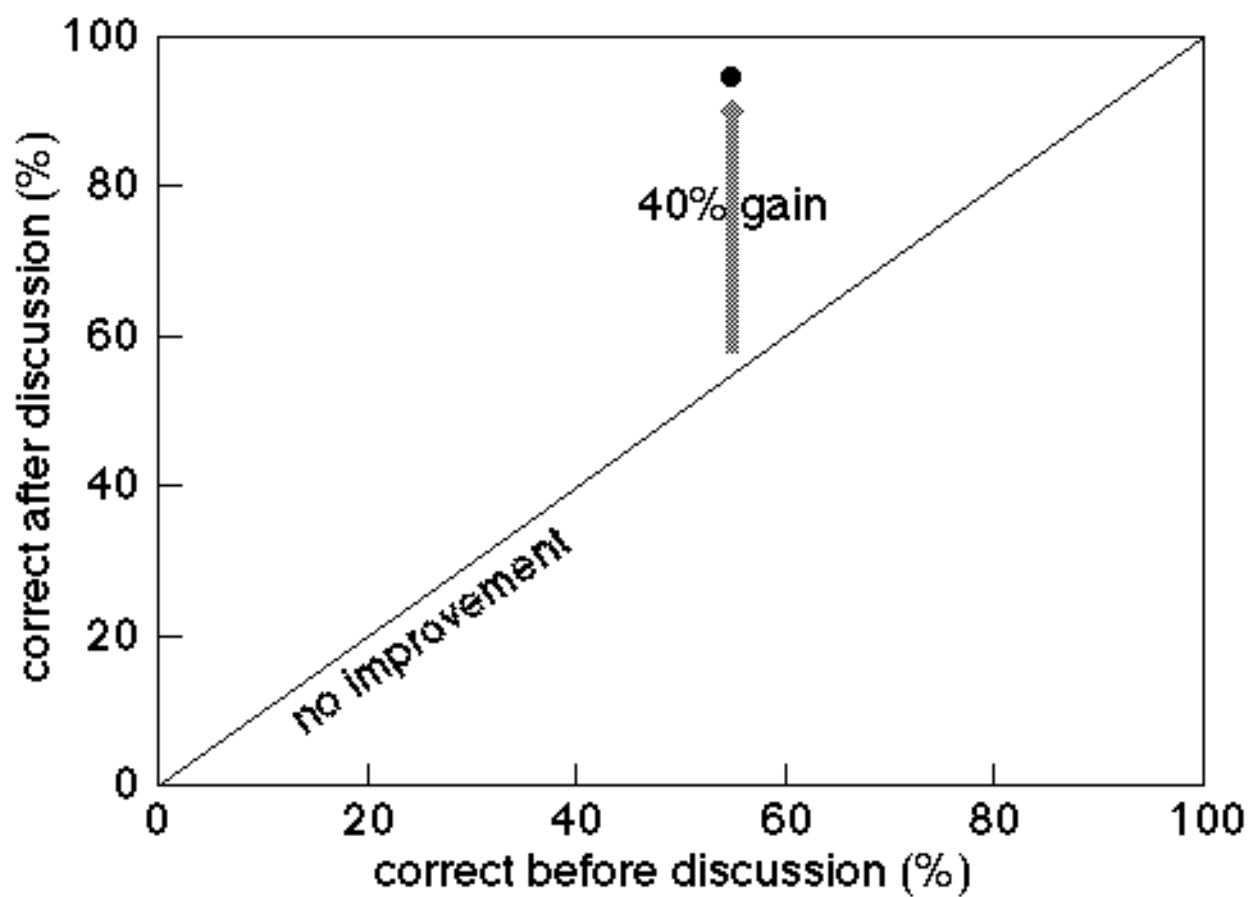

CONCEPTEST

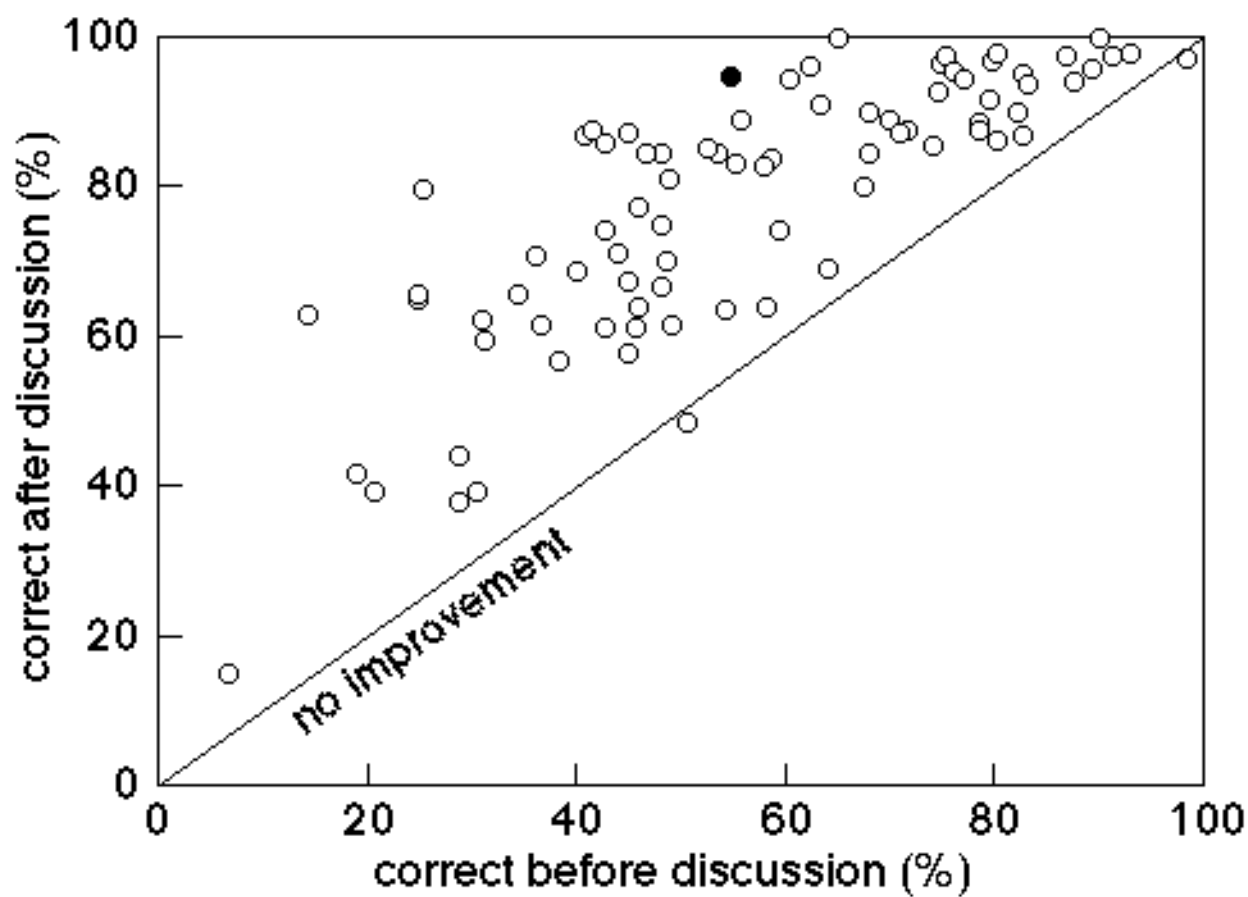

CONCEPTEST

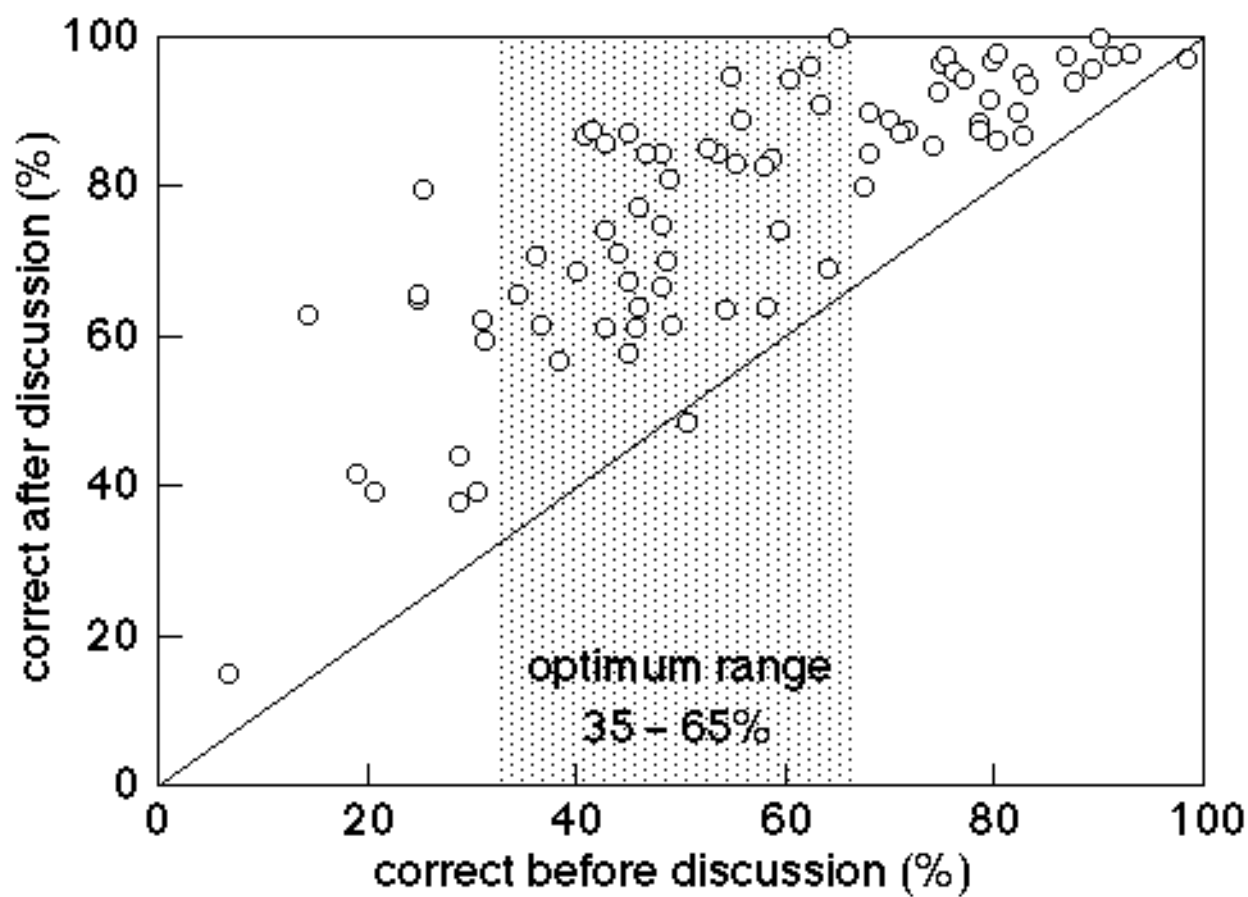



Is it any good...?

RESULTS

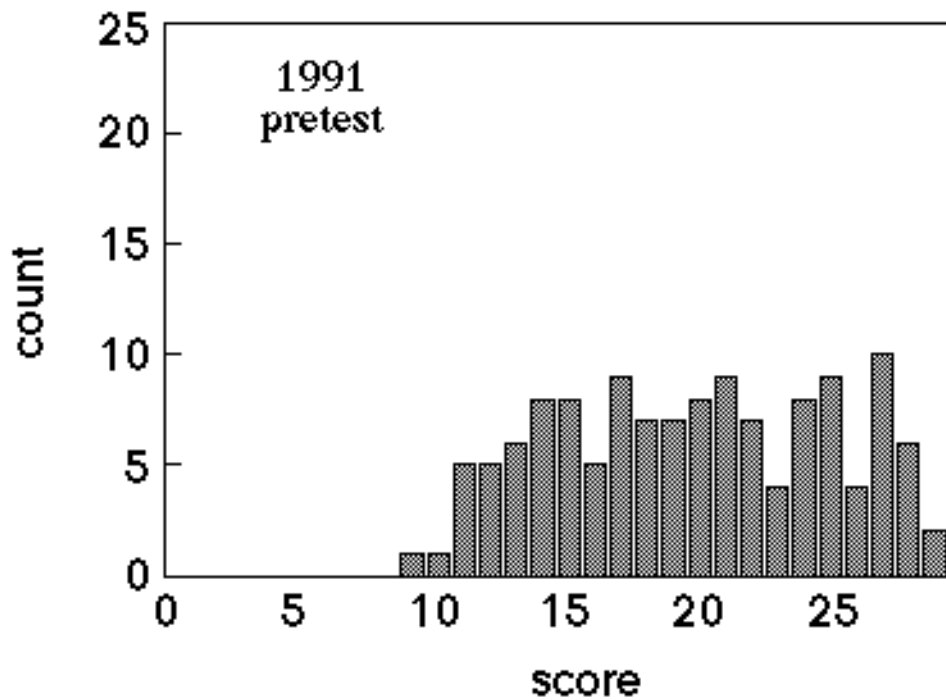

RESULTS

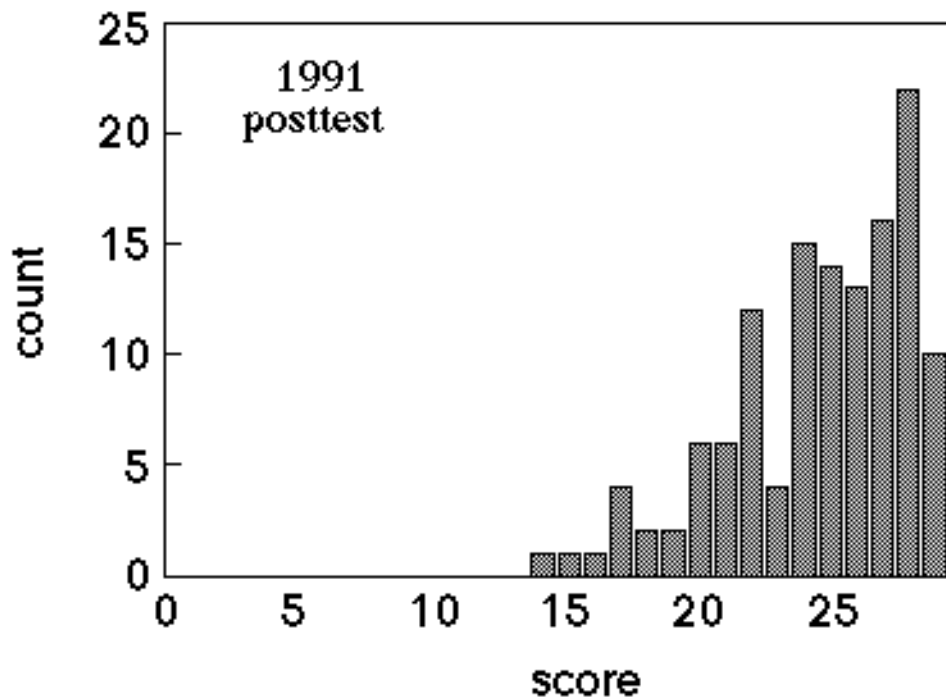

RESULTS

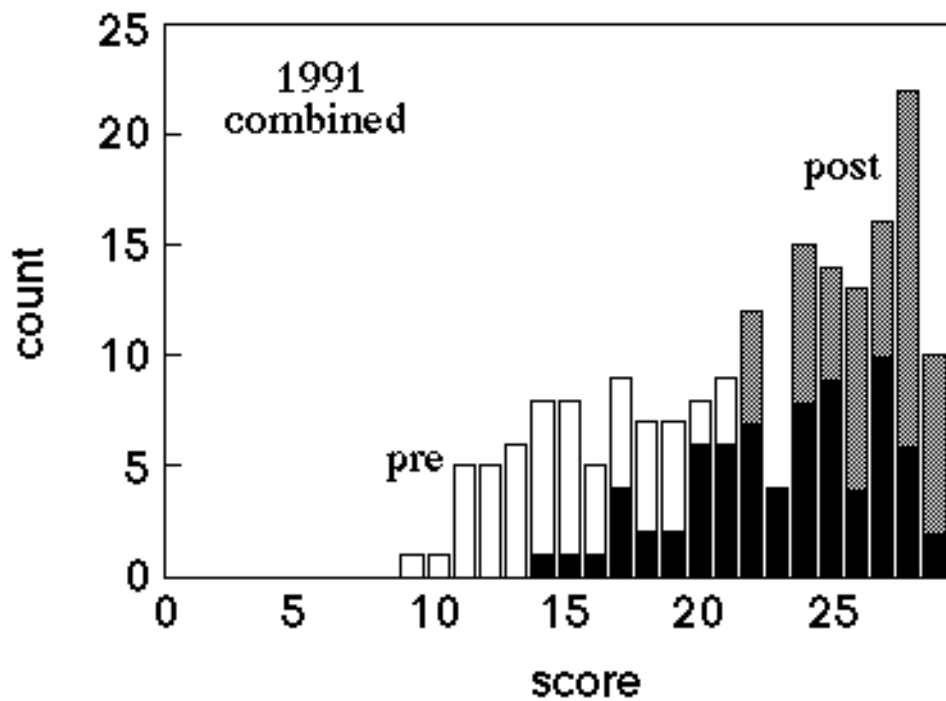

RESULTS

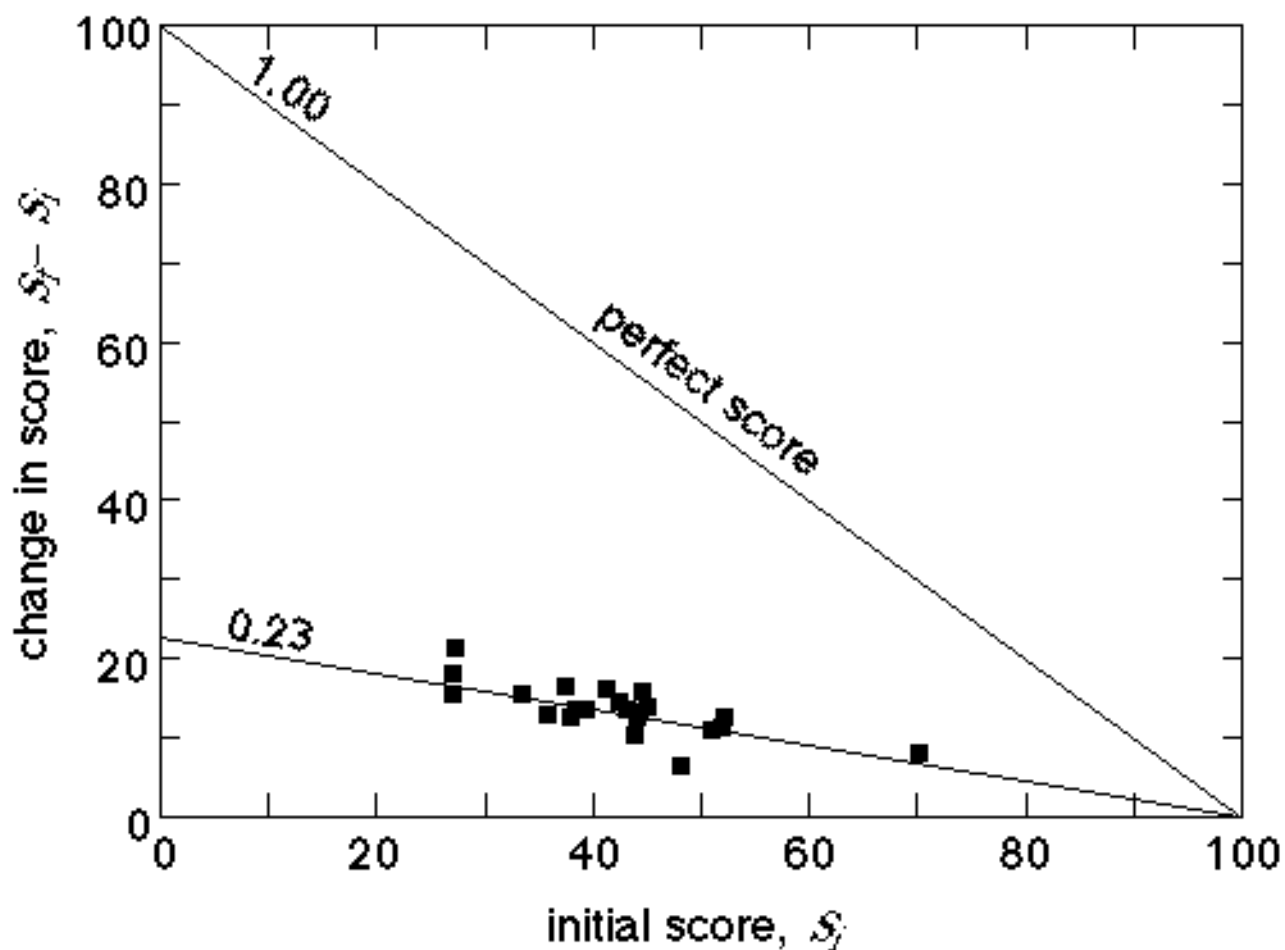

RESULTS

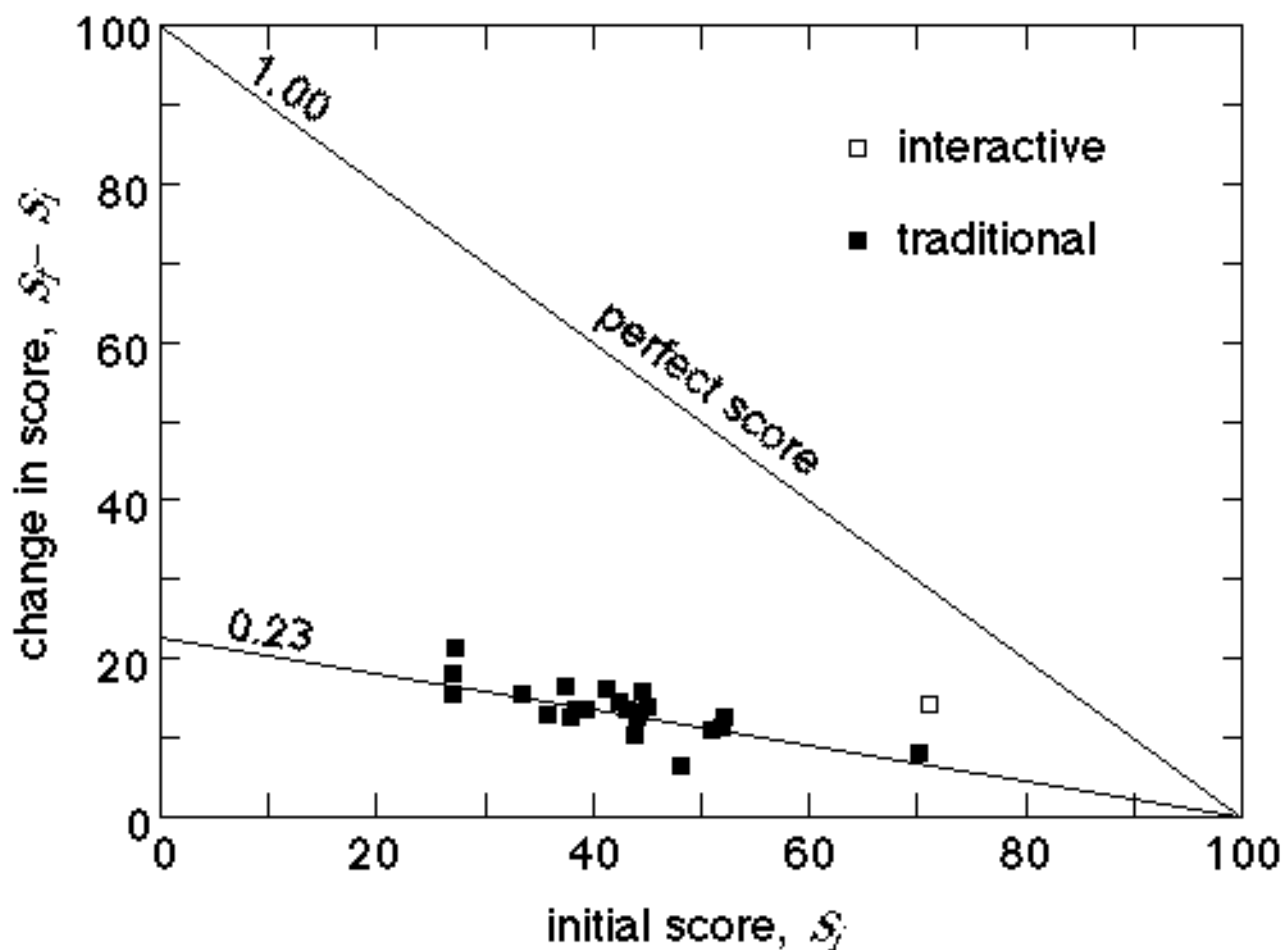

RESULTS

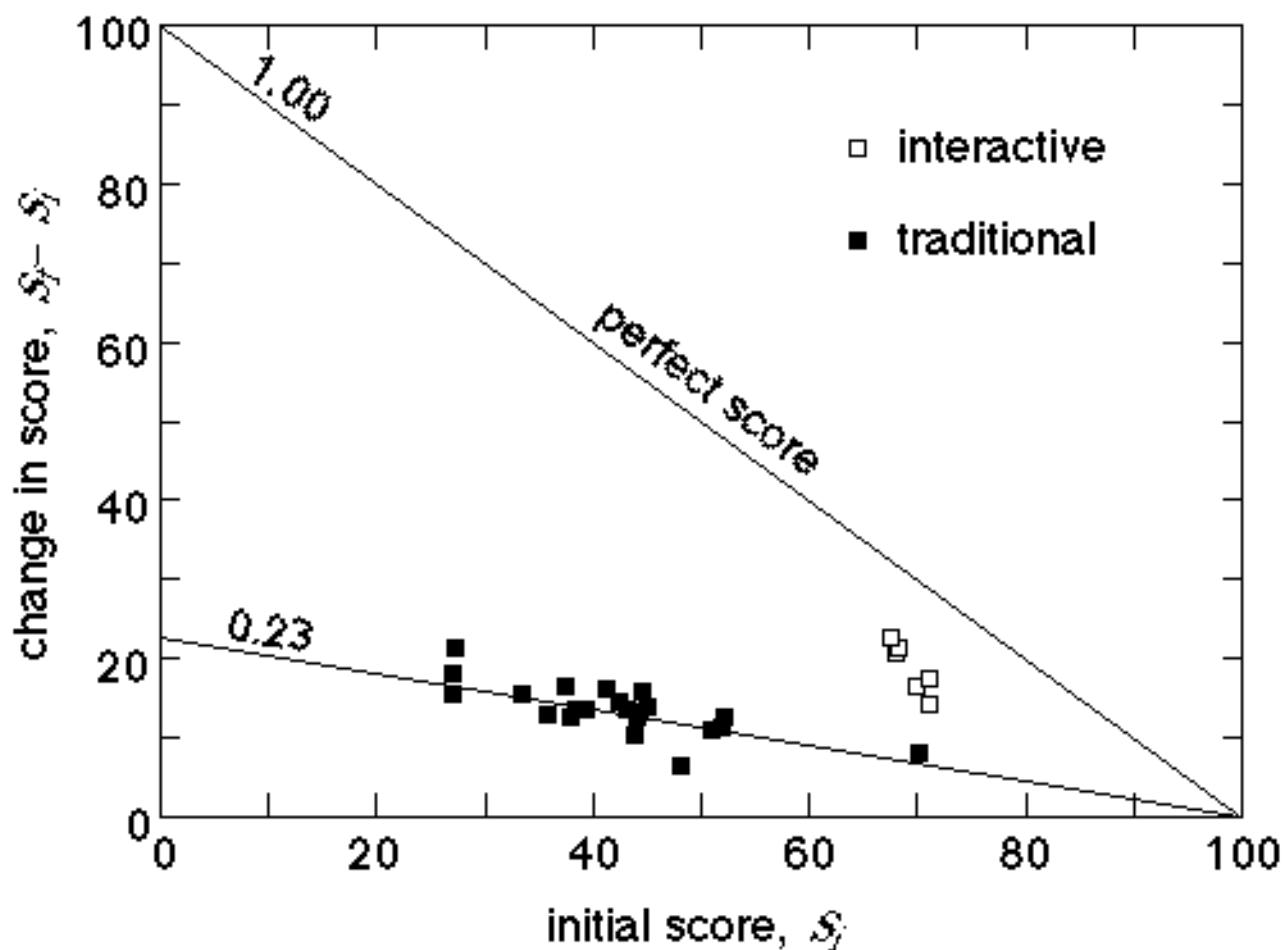

RESULTS

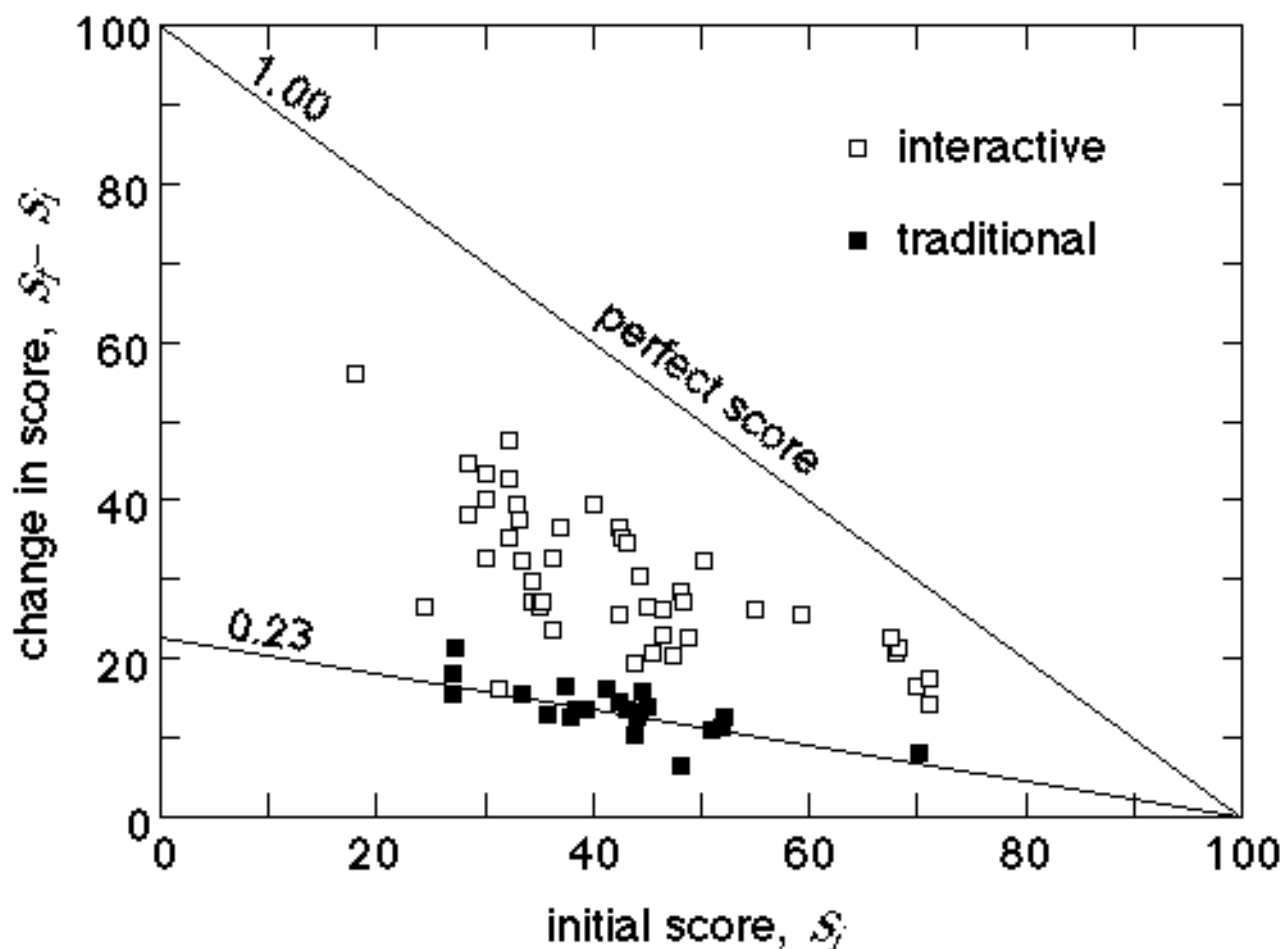

RESULTS

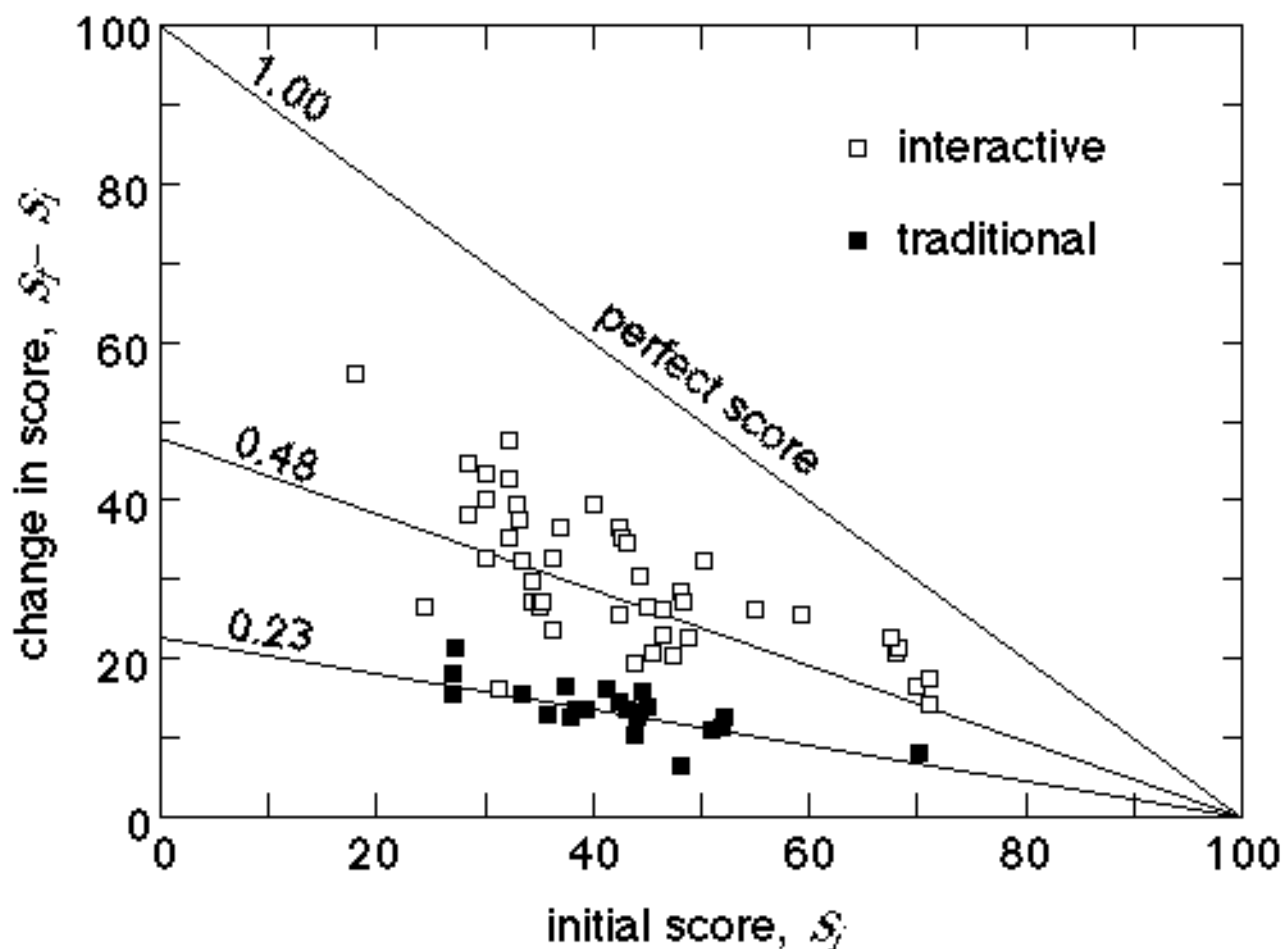

RESULTS

What about problem solving...?



RESULTS

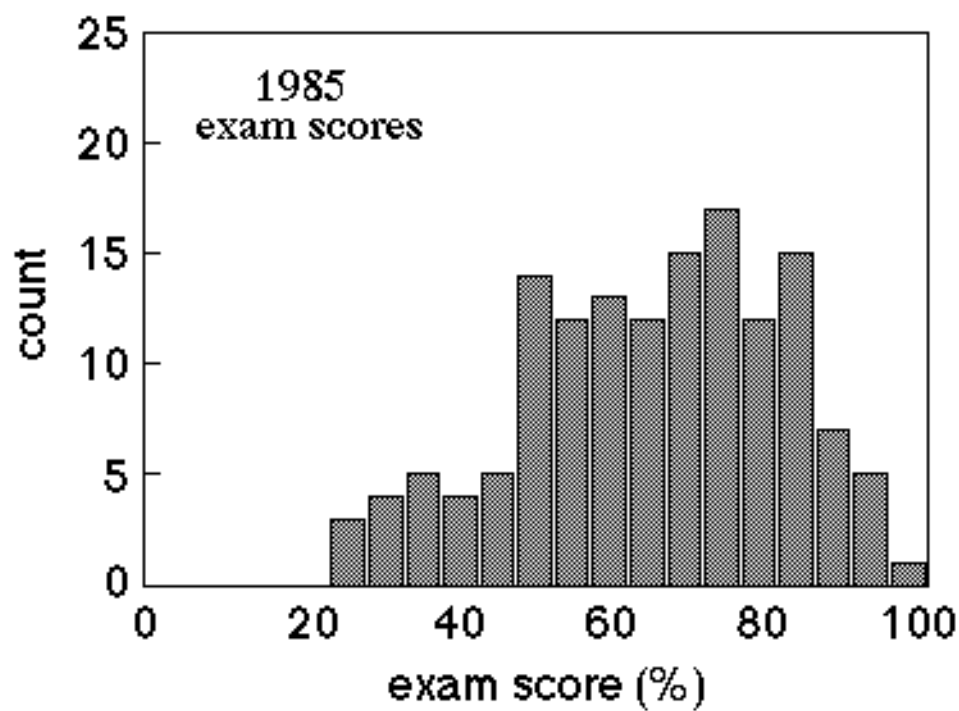

RESULTS

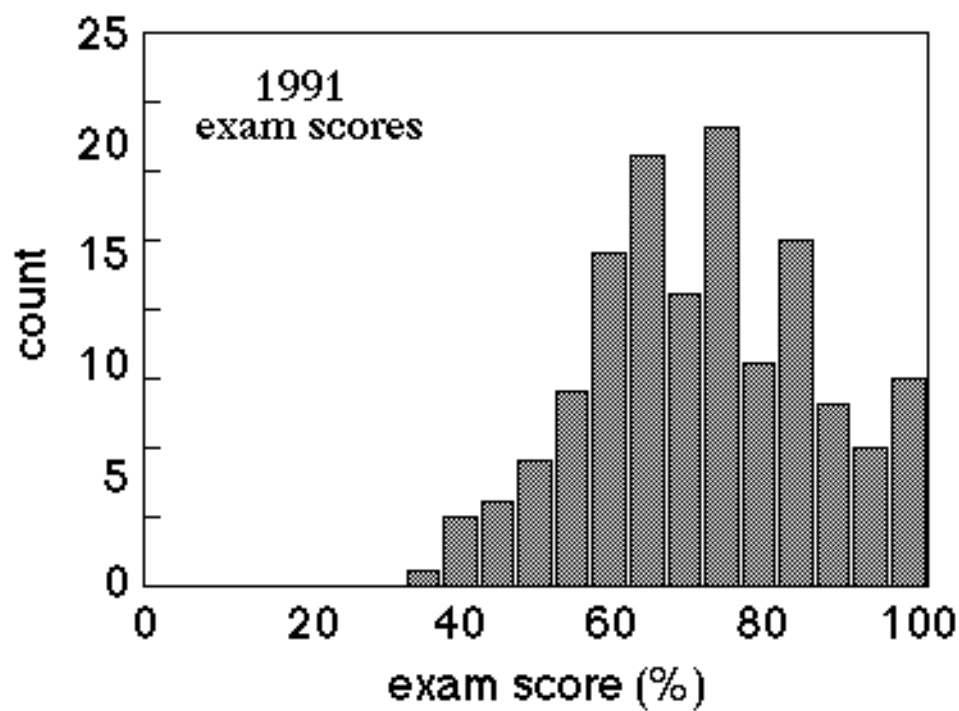

RESULTS

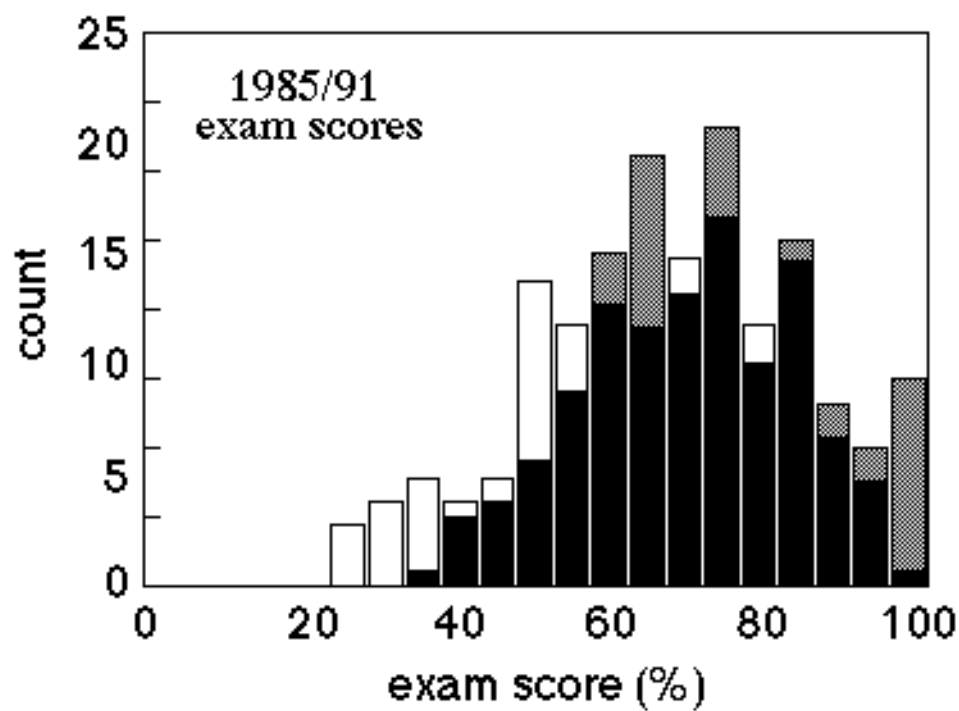

RESULTS

So, better understanding leads to better problem solving ...



RESULTS

So, better understanding leads to better problem solving ...

(but “good” problem solving doesn’t always indicate understanding!)



STUDENT REACTIONS



WHO BENEFITS?

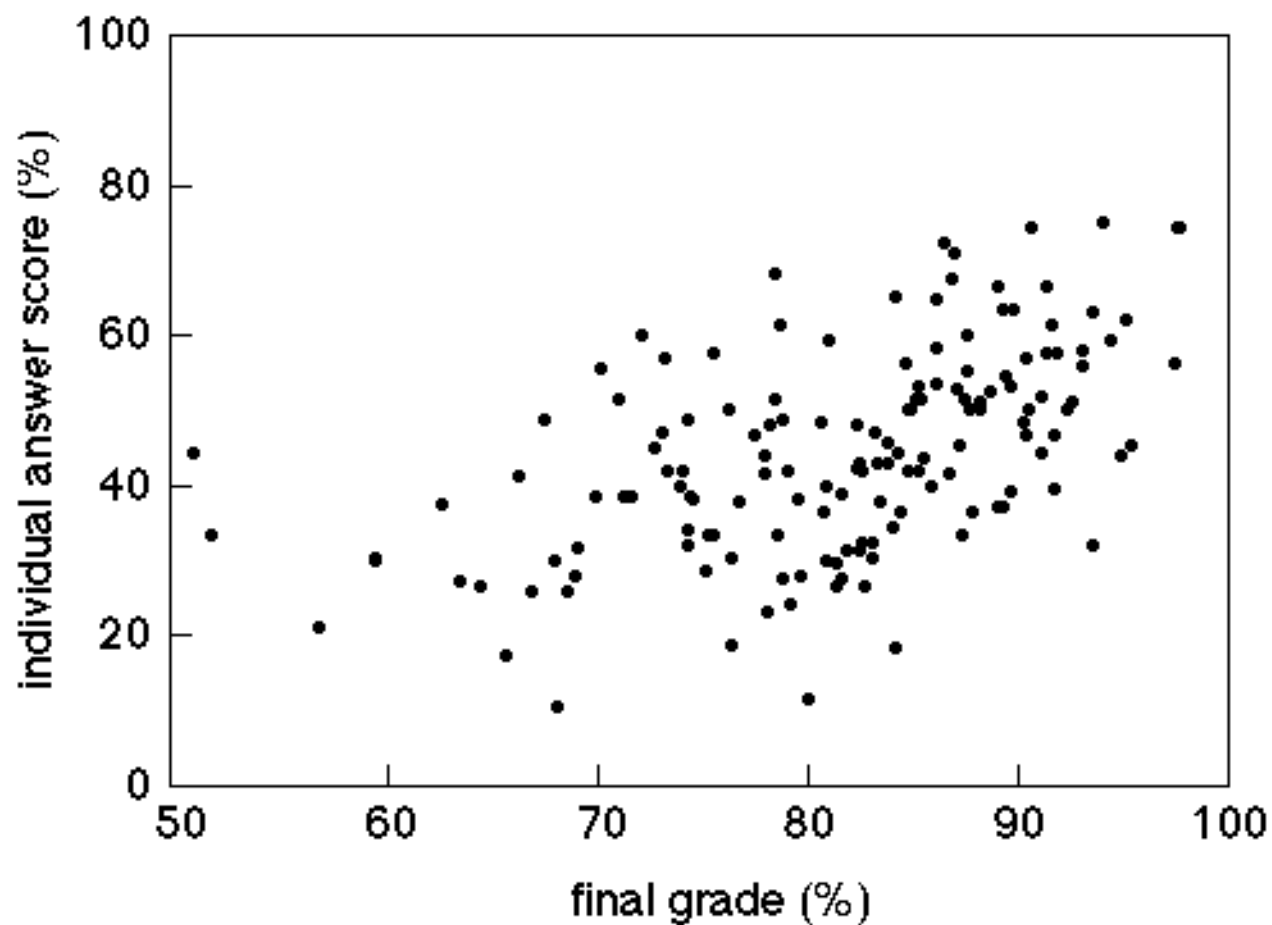

WHO BENEFITS?

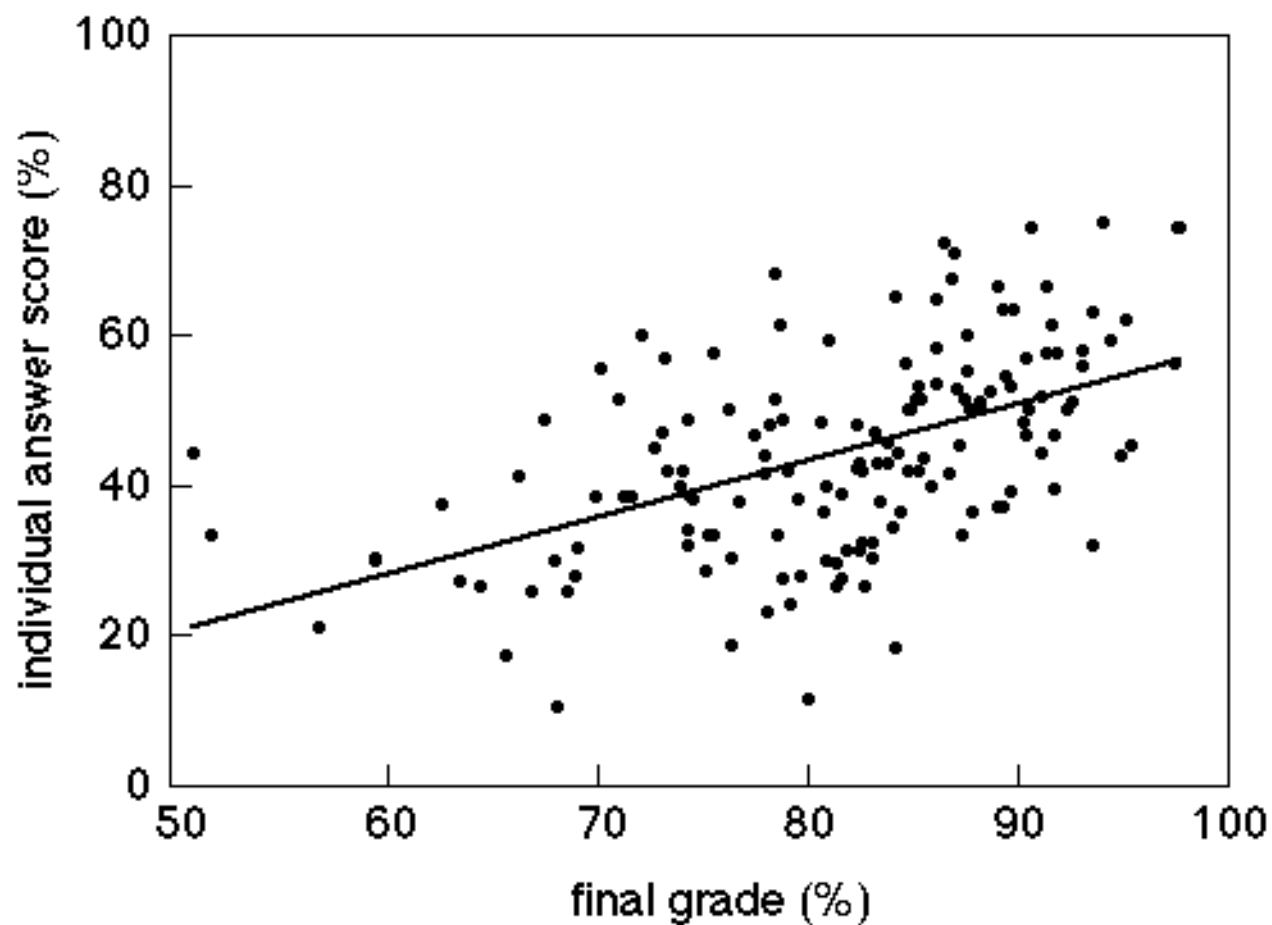

WHO BENEFITS?

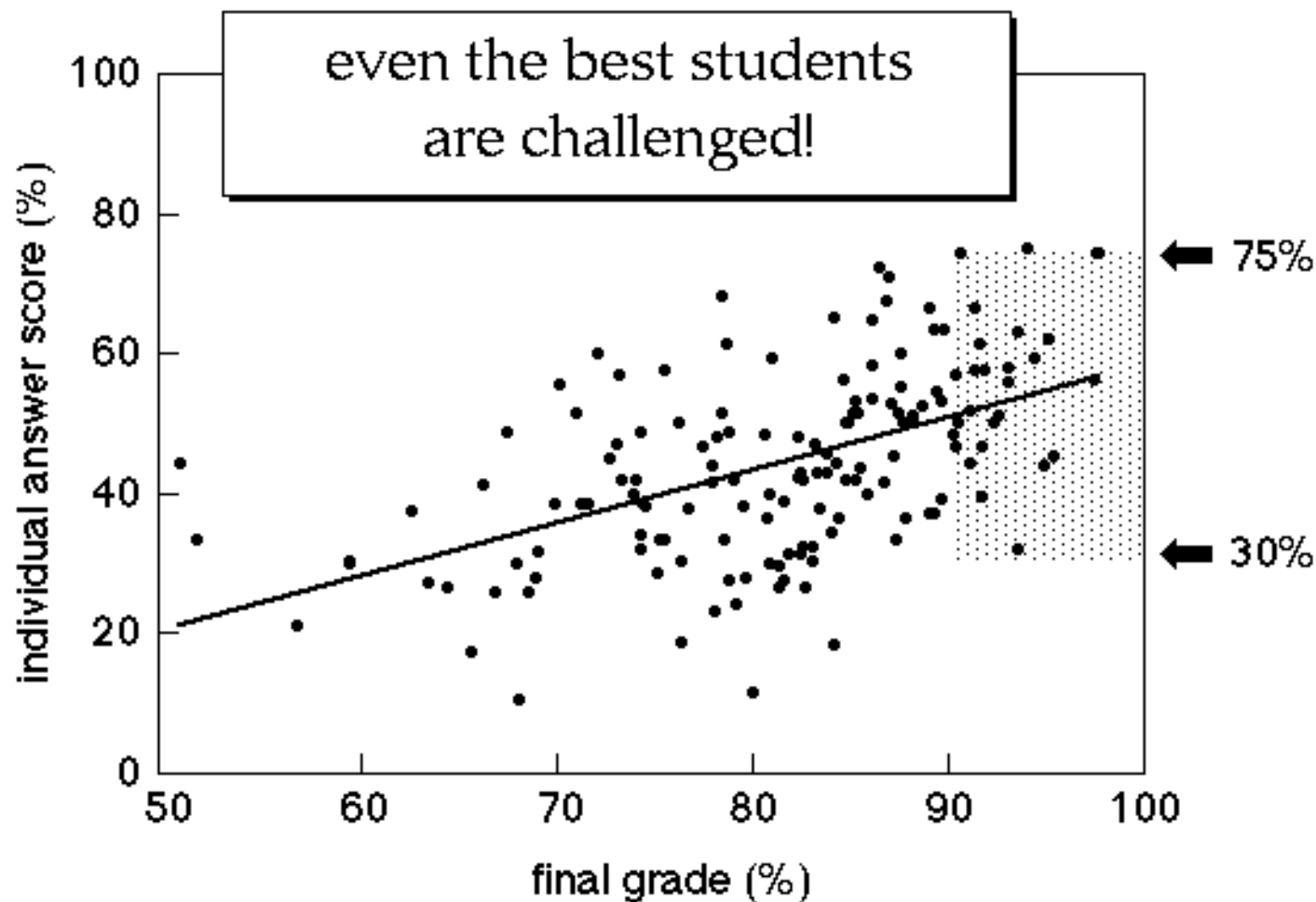

WHO BENEFITS?

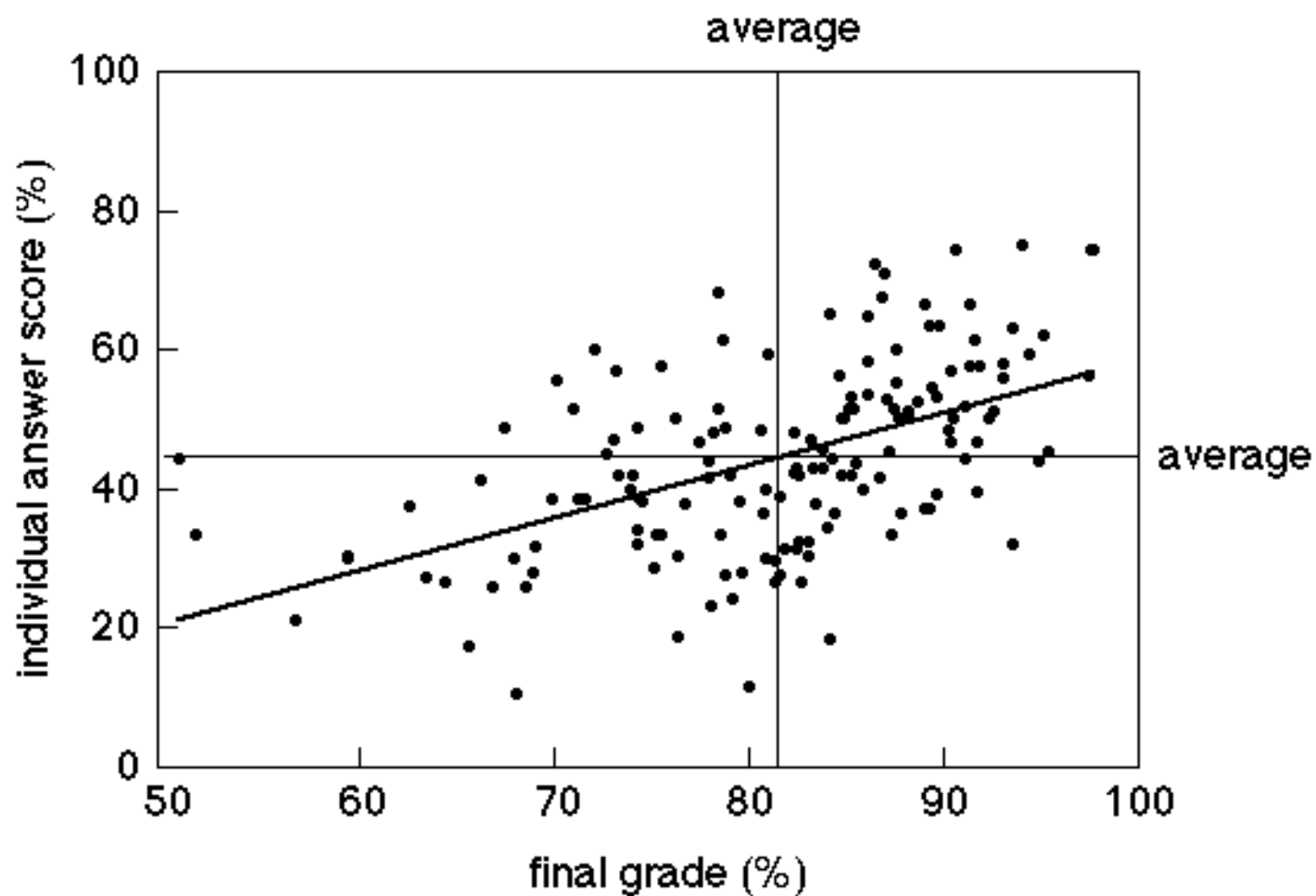

WHO BENEFITS?

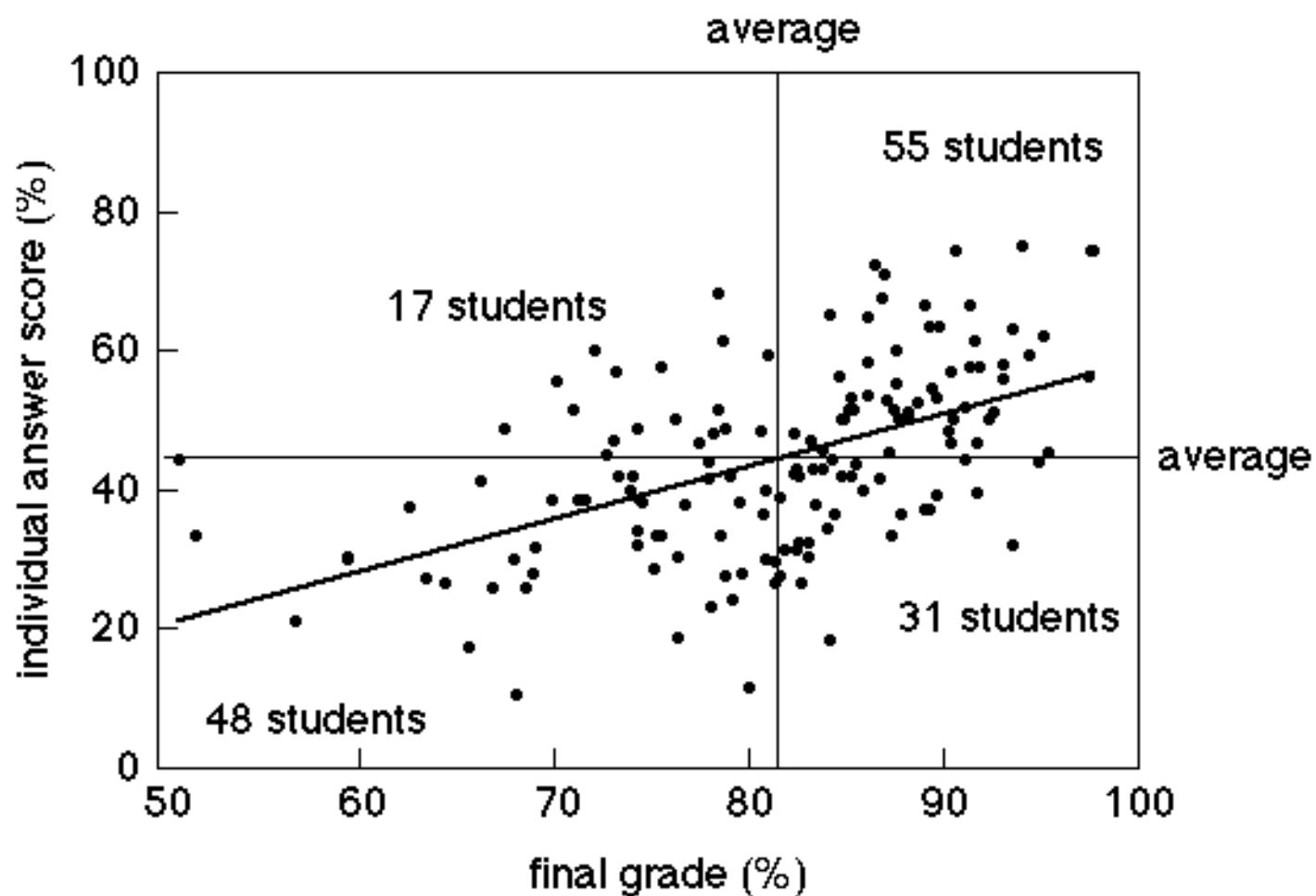

Why does it work?

Students:

- gets them thinking
- helps uncover misunderstandings
- boosts confidence

Faculty:

- change of format, not content
- with existing questions, little effort
- adaptable



Acknowledgments

Catherine Crouch (Harvard)
Deborah Alpert (Harvard)
Michael Aziz (Harvard)
William Paul (Harvard)
Tim Bozik (Prentice Hall)
David Hestenes (ASU)

Additional information:
<http://galileo.harvard.edu>

©1998 Eric Mazur

